

Project 227
AB



**DEVELOPMENT OF GROUTED
TUBULAR JOINT TECHNOLOGY
FOR OFFSHORE STRENGTHENING AND REPAIR**

**OFFSHORE INSTALLATION
STUDY**

DOC REF C14100R015 Rev 0 DECEMBER 1994

MSL Engineering Limited

MSL Engineering Limited

Purpose of Issue	Rev	Date of Issue	Author	Agreed	Approved
Issued to PSC	0	December 1994	EPS	DJM	

"This document has been prepared by MSL Engineering Limited for the Participants of the Joint Industry Project on Development of Grouted Tubular Joint Technology for Offshore Strengthening and Repair. This document is confidential to the Participants in the Joint Industry Project, under the terms of their contract for participation in the project"

JOINT INDUSTRY PROJECT

**DEVELOPMENT OF GROUTED
TUBULAR JOINT TECHNOLOGY
FOR OFFSHORE STRENGTHENING AND REPAIR**

**OFFSHORE INSTALLATION
STUDY**

DOC REF C14100R015 Rev 0 DECEMBER 1994

MSL Engineering Limited
MSL House
5 - 7 High Street, Sunninghill,
Ascot, Berkshire. SL5 9NQ

Tel: +44 (0)1344 874424
Fax: +44 (0)1344 874338

NUMBER	DETAILS OF REVISION
0	Issued to PSC, December 1994

JOINT INDUSTRY PROJECT
DEVELOPMENT OF GROUTED
TUBULAR JOINT TECHNOLOGY
FOR OFFSHORE STRENGTHENING AND REPAIR

OFFSHORE INSTALLATION
STUDY

CONTENTS

	<u>Page</u>
CONTENTS	3
1. INTRODUCTION	5
2. SUMMARY	6
3. SCENARIOS	7
3.1 Horizontal Member Grouting	7
3.2 Inclined Member Grouting	7
4. OFFSHORE GROUTING PROCEDURES	8
4.1 Horizontal Member	8
4.1.1 General Principles	8
4.1.2 Seals For Partial Grout Filling	9
4.1.3 Grouting Procedure	10
4.2 Inclined Member	15
4.2.1 Member Preparation	16
4.2.2 Grouting Procedure	17
4.3 Fatigue Details	22
4.4 Construction Details	23
4.4.1 Grout Inlets/Outlets	23
4.4.2 Grout Bags	23



CONTENTS - Cont'd.

	<u>Page</u>
5. GROUT MIXES	25
5.1 Design Requirements	25
5.2 Grout Mix Proportions	25
5.2.1 Oilwell Cement	25
5.2.2 Dutch Encillite	25
5.3 Materials	26
5.4 Grout Mixing	26
5.5 Quality Control Requirements	26
5.5.1 Equipment	26
5.5.2 Slurry Density Measurements	26
5.5.3 Cube Manufacture, Curing and Testing	27
5.5.4 Sampling and Testing Procedure for Each Member	27
5.5.5 Transportation of Test Cubes	28
6. EQUIPMENT LISTS	30
7. ESTIMATED OFFSHORE DURATIONS	31
8. ESTIMATED OFFSHORE COSTS	34

TABLES

FIGURES



1. INTRODUCTION

This document has been prepared within the Joint Industry Funded Project on Grouted Joints. It presents a collation of the experience gained and procedures used on a number of projects where member grouting has been used as a strengthening measure. Two scenarios are used to illustrate the procedures.

Reference is made to previous offshore projects to evaluate durations of offshore activities which are itemised for use by Participants in preparing timescale and cost estimates for future projects.

There is a certain amount of commonality in the detailed grouting procedures which is dependent of the particular scenario. Other diving related operational matters such as permissible dive times, diving support and detailed equipment needs are outside the scope of this document and so are not addressed

2. SUMMARY

Two repair scenarios are investigated where grouted member technology is used as a strengthening measure. One is horizontal member filling used for joint strengthening, and the other is an inclined member filling used, for example, to reinforce a dented brace member.

Information has been extracted from actual offshore diving logs to prepare timescale estimates for the two scenarios. Cost estimates have been prepared, which depending on the complexity of diving operations, indicate that the cost of such an operation is in the range of £121,500 to £260,000.

Detailed grouting procedures, grout mixing and quality control procedures are provided.

3. SCENARIOS

Two scenarios for grouting of members are studied which represent the most likely applications for the technology offshore. Grouting of legs has not been considered for the following reasons:-

- In many cases there is a pile passing through the leg in which case the chord member is not fully grouted.
- Where there is not a pile inside the legs, many legs are used for storage of water or diesel, and so grout filling would not be an acceptable option.
- Legs may contain ring stiffeners and internal diaphragms at joints which have not been considered in this study in combination with grout filling.
- The volume of grout required is an order of magnitude greater and would require special consideration in regard to the heat of hydration generated.

3.1 Horizontal Member Grouting

Figure 3.1 shows the general arrangement of a horizontal member in a plan level conductor bay which has been grout filled. Grouting would be required in this instance to increase the fatigue life of the joints along the member length. Such a member may have a constant diameter all the way along or there may be expanded joint cans at intervals along the length, see Figure 3.2. This scenario may be taken as being representative of a horizontal member and the procedures may be repeated for similar configurations involving other sizes and lengths of members.

3.2 Inclined Member Grouting

Figure 3.3 shows the general arrangement of a jacket in which inclined member grouting was required to a face frame member due to damage which has occurred during installation. In this instance it may be necessary to fill the whole length of the member or it may only be required to fill the lower portion. Note, however, that the grout filling provided local stability around dents. It was not the intention to increase the axial capacity of the member above its design value. If such a case were required, the procedures proposed would not be satisfactory as they do not result in 100% filling of the member, see Section 4.2.

4. OFFSHORE GROUTING PROCEDURES

4.1 Horizontal Member

4.1.1 General Principles

In order to simplify diver operations it is assumed in these procedures that all access to the inside of the member is gained from the uppermost part of the tube. In this way the diver can sit on the tube whilst working rather than hanging underneath. A problem has now been created since it is not advisable to allow grout to free fall through the flooded member as dilution or segregation of the grout slurry will occur. To overcome the problem, the inlets are extended to within approximately 50 mm of the bottom inside surface of the tube, see Figure 4.1.

Two options have been used in the past to attach the inlets and outlets. The first is to drill and tap holes in the tube with threads which match those of the valves and fittings, see Figure 4.1. The second is to drill or burn and grind dress a hole and clamp the fittings over the hole, as illustrated in Figure 4.2. Drilling and tapping will withstand higher grout pressures but requires greater offshore effort. Clamped inlets and outlets may be more convenient on inclined members where it is difficult to locate and handle the drill framework.

In order to maximise the extent of grout filling, a number of simple rules should be followed:-

1. Displace water rather than air when grouting.
2. Grout from the bottom up; ie. inlet at lowest point of circumference at lower end of member.
3. Grout through one inlet only, otherwise water gets trapped in the middle and a void forms.
4. All grout placed in a single, essentially continuous, operation.
5. Grout should fill member as a wave front by starting at one end of the member and moving away from it.

Outlets and vents should be placed at intervals along the member to allow air to escape but also to allow 'bleed water' to migrate out of the member. Bleed is the phenomenon whereby grout particles in a grout column settle downwards during the setting process leaving a layer of water on the top surface of the column. The extent of bleed in the mixes given in Section 5 is usually less than 0.5%. Outlets and vents often serve a dual purpose as they act as sampling tubes to trap grout for testing. A typical sampling tube is manufactured from 2" NB piping and is 1.2 m (4 ft) long. If such a sampling

tube is to contain the likely maximum production of 'bleed water' from a grouted member then the sampling tubes/vents/outlets should have the following distribution.

Member OD (mm)	Length of member per sampling tube/vent (m)
324 ϕ	13.15
406 ϕ	8.37
457 ϕ	6.62
610 ϕ	3.71

If the sampling tubes are larger or grout returns are piped to the surface then fewer will be needed. However, in order to comply with the five simple rules above it is still necessary to have a minimum of two outlets per member and two inlets (one to use and one spare in case of blockage or damage). Also a vent/sampling tube shall be placed at each high point, eg expanded joint can, see Figure 3.2 where a pocket of air or water can form.

4.1.2 Seals For Partial Grout Filling

In certain circumstances it may not be desirable to completely grout fill a member as to do so may involve an unduly large volume of grout or the additional weight may not be acceptable. Should this be the case then internal member seals (or plugs) shall be used to confine the grout. The accepted method of achieving this type of seal is with grout bags. Typical details and specifications are provided in Section 4.4.2. Grout bags are deployed through, typically, a 4" ϕ hole in the member and filled with grout to a specified pressure which is then locked into the bag. The grout is allowed to set for approximately 24 hours, before the main grouting operation commences. This technology was originally developed for grouted clamps where an annulus has to be sealed. The material is more robust than neoprene or similar elastomers and can be manufactured in thinner, lighter, more easily handled cross sections, It also has the advantage that pressure does not have to be maintained while the main grouting job is underway. Furthermore, the seal also has the same stiffness and strength characteristics as the body of the grout, which is of particular benefit with clamped repairs.

Particular attention should be taken in the use of internal seals where it is proposed to take grout returns back to the surface for sampling. An internal seal must generate sufficient friction/adhesion to the inside surface of the member so that it can withstand the pressure generated by the head of grout. Where a large pressure would be generated then grouting to surface returns may not be possible, and sample tubes will have to be used.

4.1.3 Grouting Procedure

A typical grouting procedure is given in this section.

The member to be grout-filled shall be fitted with two (2 N^o) grout inlet points and three (3 N^o) grout outlet points. The general arrangement and locations of inlets and outlets are shown in Figures 3.2,4.1 and 4.3. The locations shall be chosen to avoid circumferential girth welds. Precise details of pipe fittings can be confirmed in liaison with the diving/grouting contractor. However it is not recommended that any smaller fittings than 1½" are used, as large grouting back pressures could be generated due to the resistance to flow of grout in a smaller inlet.

Members shall be fitted with grout inlet and outlet points by drilling and tapping the upper surface of each horizontal member. Similar procedures would be followed if clamped inlets and outlets are used. The method described in this procedure for grouting relies on grout return lines to the surface. However, the use of sample tubes at grout outlet points is permitted within the framework of the procedure described herein.

It is essential that leak testing and grouting operations are immediately consecutive and are not commenced until a suitable weather window is forecast. The required timescale will be reviewed by the Grouting Contractor, who will take the decision to proceed in consultation with the Client.

The diver will operate the valves as instructed by the Grouting Supervisor. Grout should be allowed to issue through the outlet points until good quality grout is observed. As a general rule, there should be a steady and consistent flow of dense grout with no intermingling of sea water and no sign of air bubbles.

The grout inlet points are defined as IP1 and IP2, and the grout outlet points (vents) are defined as OP1, OP2 and OP3, see Figure 3.2. The inlet and outlet valve arrangements are shown schematically in Figures 4.1 and 4.3. Suitable outlet arrangements shall be specified if sampling tubes are adopted.

4.1.3.1 **Grout Connections**

Grout inlet and outlet points will be fitted with valves as shown in Figures 4.1 and 4.3. In addition, grout inlet points IP1 and IP2 will be fitted with bypass valves. All grout inlet/outlet points will also be fitted with a half 'Weco' coupling to take the grout inlet and vent hoses. Suitable connection and valve details shall be specified at the vent locations if sampling tubes are adopted.

BEFORE FITTING, CHECK THE OPERATION OF ALL VALVES.
All connections should be well greased. The grout inlet line shall be attached to the member at grout inlet point IP1 (see Figure 3.2). If

grouting operations run smoothly (ie. no blockages occur and weather remains favourable), all grout is input through this point. The grout return lines to the surface shall be attached to outlet points OP1, OP2 and OP3 or; conversely, sampling tubes shall be attached at these locations.

NOTE: If grouting operations have to be abandoned part-way through operations, detailed contingencies are given in Section 4.1.3.13.

4.1.3.2 Leak Testing

NOTE: Before proceeding beyond this point, it is essential that a suitable weather window is expected.

BEFORE ANY PUMPING COMMENCES ENSURE THAT AT LEAST ONE VALVE IS OPEN AT THE MEMBER.

4.1.3.3 Filling Member with Dye

Close all valves at IP2, and open all valves at OP1, OP2 and OP3. Close bypass valve at IP1. Connect inlet grout hose to IP1, and return lines/sampling tubes to OP1, OP2 and OP3.

Pump water containing fluorescent dye, concentration 1:1,000,000, through the grout inlet line. Stop pumping when dye issues from grout inlet points. Close valves at OP1, OP2 and OP3.

Pressurise water to a pressure equivalent to the head of grout for surface return lines or 12m head of grout for sampling tube arrangements. The pressure reading will depend on type of mixer used.

4.1.3.4 Inspection for Leaks

Identify any leak points by evidence of dye. All inlet points and outlet points should be checked. In addition, the intersection welds at the member ends shall be checked. Go to Sections 4.1.3.5 or 4.1.3.6 if leaks noted.

If no leaks are apparent after a period of three minutes, go to Section 4.1.3.7.

4.1.3.5 Remedial Procedure - Leak at Inlet or Outlet Points

Check that valves are closed. Check that valves are correctly attached to the member at the threaded fitting. If leak persists, detach subject valve fitting and remove to surface for inspection and check integrity of threaded grout point in member wall.

4.1.3.6 **Minor Leaks**

If leaks are minor it is probable that they will be self-sealing when grouting commences. Minor leaks are those evidenced by dye locally present in the sea water but not visibly issuing from the leak point. The Grouting Supervisor shall be responsible for confirming any leak as minor and will decide whether remedial action is necessary, prior to grouting. Minor leaks and leaks at member welds may be remedied by sealing the leak point with underwater tape.

4.1.3.7 **No Leaks**

If no leaks are evident, or only minor leaks deemed acceptable by the Grouting Supervisor, a second (confirmatory) inspection shall be made.

4.1.3.8 **Check Valve Operation**

Open the valves in the following sequence, whilst slowly pumping dye water, ensuring in each case an immediate and abundant flow of dye water, before reclosing valve.

Sequence OP1, OP2, IP2 (bypass valve remains closed), OP3.

In the event that no flow occurs at a valve, the valve shall be replaced and the procedure from Section 4.1.3.1 onwards shall be repeated.

4.1.3.9 **Grouting the Member**

This operation should follow immediately after a successful leak test.

It is vital that at least one outlet point is open at all times.

4.1.3.10 **Grouting Procedure**

Before any grout is injected, divers will confirm the valves are set as follows:-

- (i) Grout inlet hose line is attached at IP1, inlet valve closed, bypass valve open.
- (ii) Grout return hose lines/sampling tubes are attached at OP1, OP2 and OP3, outlet valves open.
- (iii) Inlet valve at IP2 open, bypass valve closed.

Thus, valve status required is as scheduled below:-

Inlet Point	Valve Position	Outlet Point	Valve Position
IP1 - inlet valve - bypass valve	Closed Open	OP1	Open
IP2 - inlet valve - bypass valve	Open Closed	OP2 OP3	Open Open

Mix Grout

Mix grout to a specific gravity of 2.02 ± 0.02 . Confirm SG=2.02 using a pressurised mud-balance. If acceptable, take a sample for grout cubes. If SG is less than 2.00, continue mixing grout until desired density is achieved and then take sample for grout cubes.

See Section 5 for mixing, sampling and testing of grout.

Valve Operating Sequence

Ensure grout inlet hose from surface to member is free of any obstructions, 'kinks' or 'crimps'.

Pump grout down the inlet hose until the line is full of grout and grout issues from the bypass valve.

Open inlet valve at IP1.

Close bypass valve at IP1.

Pumping is continuous. The Grouting Supervisor will assess when grout samples are to be recovered for density checks, in accordance with the specification noted in Section 5.

When grout issues from IP2, check that at OP1, OP2 and OP3 all valves are open. Close inlet valve at IP2.

Close valve at outlet point OP1.

- When grout issues from the outlet points OP2 and OP3, continue pumping, and take density measurements. Once satisfactory grout has been confirmed from OP2 and OP3, first open valve at OP1, and then, close valves at OP2 and OP3.
- When grout issues from the outlet point OP1, continue pumping and take density measurements.

- Once satisfactory grout has been confirmed from OP1, open valves at OP2 and OP3, and reconfirm satisfactory grout density from all three outlet points.
- Following confirmation of satisfactory grout densities, close inlet valve at IP1, and open bypass valve at IP1.
- **DO NOT REMOVE INLET HOSE OR SAMPLING TUBES UNTIL SATISFACTORY GROUT DENSITIES HAVE BEEN CONFIRMED AT ALL THREE OUTLET POINTS OP1, OP2 AND OP3.**
- Pump seawater down the grout line, to flush to sea. Disconnect grout inlet hose at IP1 at member and retrieve to surface. DO NOT remove the grout return lines/sampling tubes, as the head of grout serves the required function of surplus 'feed' grout during the initial set phase of the grout in the member. Ensure that all three valves at OP1, OP2 and OP3 are open.

4.1.3.11 **Short Stoppages**

If a blockage occurs during grouting, adopt the following procedure:-

Open bypass valve at IP1.

Close inlet valve at IP1.

If no grout flows, change the inlet grout hose. If grout flows, the problem is not in the hose. Flush the inlet grout line with seawater, detach the Weco coupling from IP1 and reattach at IP2. Close inlet valve at IP2, open bypass valve, fill the hose with grout. When grout issues from the bypass valve, open inlet valve at IP2, close the bypass valve and revert to the procedures in Section 4.1.3.10.

4.3.1.12 **Longer Stoppages**

In the event of a grout flow problem or delay during grouting operations, where such delays may exceed one hour, member flushing procedures must start.

4.1.3.13 **Flushing Procedure**

Flushing must be carried out if grout flow problems occur which may delay operations for more than one hour.

- (i) Open bypass valve at IP1, shut inlet valve at IP1, and flush grout hose to sea. Wash out grout mixer.

- (ii) Pumping seawater, open and close the valves in the following sequence. Do not close a valve until grout has ceased to issue from the valve.
- (iii) Open inlet valves at IP1 and IP2. Close bypass valve at IP2. Flush for 15 minutes.
- (iv) Close by-pass valve at IP1.
- (v) Close inlet valve at IP2 and open all remaining outlet valves and flush for a minimum of 15 minutes. Open inlet valve at IP2, and continue flushing for a further 10 minutes.
- (vi) Diver to inspect all valves and 'rake out' where necessary.

4.1.3.14 **Post Grouting Procedure**

Flush Grout Inlet Line

Immediately after satisfactory grouting, flush the grout inlet line (via bypass) and retrieve to surface.

Return Lines/Sampling Tubes and Valve Assemblies

The return lines/sampling tubes and valves will remain in situ until the grout has achieved initial set. This will be agreed with the Client, but will not be less than 24 hours after completion of grouting. Retrieve return lines/sampling tubes and valves thereafter and place thread protector caps over inlets/outlets.

Underwater tape will be wrapped around exposed inlets/outlets if appropriate to prevent corrosion of the threads.

4.2 **Inclined Member**

The general principles for grouting horizontal members outlined in Section 4.1.1 are equally applicable to inclined members. Since the member is inclined there is no clear advantage to divers working from the uppermost surface of the member and so inlets will be placed directly on the underside of the member.

Intermediate outlets are not necessary as a vertical path is already provided for air and 'bleed water' to escape. Also fewer inlets are provided as the extreme low point of the void is comparatively small unlike a horizontal member. Sealing is provided by the lower and upper brace member welds and no further sealing is considered.

A particular difficulty arising with inclined members is getting grout to fill all the way to the top. It is not possible either due to space restrictions or geometrical

limitations to place the uppermost grout outlet exactly at the top of the member. Consequently, a void is formed by the air or water which is trapped above the outlet, see Figure 4.4. This is the reason why, in Section 3.2, it was stated that these procedures are not appropriate where the axial capacity needs to be increased above the design value. Figure 4.5 shows how the use of a weep hole can reduce the void size, (but not eliminate it completely). The following procedures are written assuming a weep hole is used, but are equally applicable if one is not.

The general arrangements of inlets and outlets are shown in Figures 4.2 and 4.6. The precise locations shall avoid circumferential girth welds, anodes and any other surface attachments.

Members shall be fitted with grout inlet and outlet points. The method described in this procedure for grouting relies on grout return lines to the surface. Where appropriate, at the upper end of each member, a small weep hole is drilled in the brace wall which permits a greater degree of member filling than would otherwise be possible. The procedures assume that only one inlet is provided and all work is carried out through a single point. It may in some circumstances be prudent to provide a second inlet to be used as a contingency.

It is essential that leak testing and grouting operations are immediately consecutive and are not commenced until a suitable weather window is forecast. The required timescale will be reviewed by the Grouting Contractor, who will take the decision to proceed in consultation with the client.

Grout Mix and Grouting Specifications are contained in Section 5.

The diver will operate the valves as instructed by the Grouting Supervisor. Grout should be allowed to issue through the outlet points (and weep holes where appropriate) until good quality grout is observed. As a general rule, there should be a steady and consistent flow of dense grout with no intermingling of sea water and no sign of air bubbles.

The grout inlet and outlet points are shown in Figures 4.2 and 4.6. Weep hole details are shown in Figure 4.5.

4.2.1 Member Preparation

4.2.1.2 General

Holes in the grout inlet and outlet points shall be placed at the locations indicated on Figure 4.7. Details of grout inlets and outlets are shown in Figures 4.2 and 4.6. Details of the inlet point indicated in Figure 4.2 shows a 6 o'clock position with respect to the brace circumference. As an alternative, a 12 o'clock position can be adopted, provided an insert pipe is specified to ensure that grout injection takes place close to the 6 o'clock location. No inlet point shall be placed within 300mm of a girth weld or tubular joint weld. In

addition, no inlet point shall be placed at any longitudinal seam weld location. If the inlet point is closer than 150mm from a longitudinal seam weld, the inlet point position shall be rotated to give a minimum circumferential separation of 150mm from the longitudinal seam weld.

Outlet points shall be placed at the highest end on the member circumference, at the locations defined, except that no outlet point shall be placed within 300mm of a girth weld or tubular joint weld. In addition, no outlet point shall be placed at any longitudinal seam weld location. If the outlet point is closer than 75mm from a longitudinal seam weld, the outlet point position shall be rotated to give a minimum circumferential separation of 75mm from the longitudinal weld.

Where appropriate, near the outlet point position, a small (ie. 12mm max diameter) weep hole is to be drilled in the brace wall, at the location shown in Figure 4.5. As an alternative, the hole can be made using a cutting rod, provided that a smooth profile free of burrs, notches and molten spatter is achieved. No longitudinal or rotational displacement of the weep hole is permitted.

The purpose of the weep hole is to permit trapped air and seawater to escape.

At each inlet and outlet location, where an inlet/outlet clamp is to be placed, all longitudinal seam welds and other surface irregularities shall be ground down to give a flush surface to the brace wall on which to place the grouting clamp. This will minimise any leakage problems associated with the clamp-member interface.

4.2.1.3 Weep hole sealing

After making the weep hole, it shall be sealed by hammering in a rubber bung or similar device. If necessary, during leak testing and grout curing, the bung shall be held in place by a nylon strap passed around the brace. The bung shall be removed during grout injection procedures to allow grout-filling to the required level; the bung shall thereafter be replaced to permit grout pressure to build and ensure grout returns to the surface.

4.2.2 Grouting Procedure

Grout inlet and outlet points will be fitted with valves as shown in Figures 4.2 and 4.6. In addition, grout inlet and outlet points will be fitted with bypass valves. All grout inlet/outlet points will also be fitted with a half 'Weco' coupling to take the grout supply and return hoses.

BEFORE FITTING, CHECK THE OPERATION OF ALL VALVES.

All connections should be well greased. The grout inlet line shall be attached to the member at the grout inlet point. If grouting operations run smoothly (ie. no blockages occur and weather remains favourable), all grout is input through this point. At the grout outlet, return lines to the surface shall be attached to the outlet valve.

NOTE: If grouting operations have to be abandoned part-way through operations, detailed contingencies are given in Section 4.2.2.11.

4.2.2.1 Leak Testing

NOTE: Before proceeding beyond this point, it is essential that a suitable weather window is expected.

BEFORE ANY PUMPING COMMENCES ENSURE THAT THE OUTLET VALVE IS OPEN AT THE MEMBER.

4.2.2.2 Filling Member with Dye

Open valve at the outlet point. Close bypass valve at outlet point. Close bypass valve at inlet point. Connect inlet grout hose to inlet point, and return line to outlet point.

Pump water containing fluorescent dye, concentration 1:1,000,000, through the grout inlet line. Stop pumping when dye issues from grout outlet point. Close outlet valve.

Pressurise water to a pressure equivalent to the head of grout held in the surface return line. The pressure reading will depend on type of mixer used.

4.2.2.3 Inspection for Leaks

Identify any leak points by evidence of dye. All inlet points and outlet points should be checked. In addition, the damage locations, weep hole seals (where appropriate) tubular joint welds and girth welds shall be checked. Go to Sections 4.2.2.4 or 4.2.2.5 if leaks are identified.

If no leaks are apparent after a period of three minutes, go to Section 4.2.2.6.

4.2.2.4 Remedial Procedure - Leak at Inlet or Outlet Points

Check that valves are closed. Check that valves are correctly attached to the grouting clamp at the fitting. If leak persists, detach subject valve fitting and remove to surface for inspection. Check integrity of

the grouting clamp gasket seal to member wall, tighten studbolts if necessary.

4.2.2.5 Minor Leaks

If leaks are minor, it is probable that they will be self-sealing when grouting commences. Minor leaks are those evidenced by dye locally present in the sea water but not visibly issuing from the leak point. Major leaks are those evidenced by a jet of dye flowing from the defective spot. The Grouting Supervisor shall be responsible for confirming any leak as minor and will decide whether remedial action is necessary, prior to grouting. Minor leaks may be remedied by sealing the leak point with underwater tape.

4.2.2.6 No Leaks

If no leaks are evident, or only minor leaks deemed acceptable by the Grouting Supervisor, a second (confirmatory) inspection shall be made.

4.2.2.7 Check Valve Operation

Open the outlet valve whilst slowly pumping dye water, ensuring an immediate and abundant flow of dye water, before reclosing valve.

In the event that no flow occurs at a valve, the valve shall be replaced and the procedure from Section 4.2.2.1 shall be repeated.

4.2.2.8 Grouting the Member

This operation should follow immediately after a successful leak test.

It is vital that the outlet point is open at all times.

4.2.2.9 Grout Injection

Before any grout is injected, divers will confirm the valves are set as follows:-

- (i) Grout inlet hose line is attached at inlet point, inlet valve closed, bypass valve open.
- (ii) Grout return hose line is attached at outlet point, outlet valve open, bypass valve closed.
- (iii) Remove seal from weep hole (if appropriate).

Thus, valve status required is scheduled below:-

Inlet Point	Valve Position	Outlet Point	Valve Position
Inlet valve	Closed	Outlet Valve	Open
Bypass Valve	Open		

Mix Grout

Mix grout to a specific gravity of 2.02 ± 0.02 . Confirm this specific gravity using a pressurised mud-balance. If acceptable, take a sample for grout cubes. If the specific gravity is less than 2.00, continue mixing grout until desired density is achieved and then take sample for grout cubes.

See Section 5 for mixing, sampling and testing of grout.

Valve Operating Sequence

- Ensure grout inlet hose from surface to member is free of any obstructions, 'kinks' or 'crimps'.
- Pump grout down the inlet hose until the line is full of grout and grout issues from the bypass valve.
- Open inlet valve at inlet point.
- Close bypass valve at inlet point.
- Pumping is continuous. The Grouting Supervisor will assess when grout samples are taken for density checks, in accordance with the specification noted in Section 5.
- When good consistency grout issues from the weep hole, check that the outlet valve is open. **SEAL THE WEEP HOLE AT THIS STAGE.**
- When grout issues from the return line at the surface, continue pumping slowly, and take density measurements.
- Following confirmation of satisfactory grout densities, close inlet valve at inlet point, and open bypass valve at inlet point. Ensure that outlet valve is open. Take sample for grout cubes from remaining grout in the grout mixer.

- DO NOT REMOVE INLET OR OUTLET HOSE UNTIL SATISFACTORY GROUT DENSITY HAS BEEN CONFIRMED AT OUTLET POINT.
- Pump seawater down the grout inlet lines, to flush to sea. Disconnect grout inlet hoses at Weco union connection locations, and retrieve to surface. Attach 'feed' hose at the outlet point to the leg using lashing material. The grout in this 'feed' hose will provide a head of grout during the initial grout set phase and permit surplus 'bleed' water to migrate out of the member.

4.2.2.10 Short Stoppages

If a blockage occurs during grouting, adopt the following procedure:-

Open bypass valve at inlet point.

Close inlet valve at inlet point.

If no grout flows, change the inlet grout hose. If grout flows, the problem is not in the hose. Therefore, it is either a fault in the inlet valve or a blockage in the grouting clamp. In either event, the grouting operation must be aborted so that the inlet valve and grouting clamp can be inspected and the fault remedied.

4.2.2.11 Longer Stoppages

In the event of a grout flow problem or delay during grouting operations, where such delays may exceed one hour, member flushing procedures must start.

4.2.2.12 Flushing Procedure

Flushing must be carried out if grout flow problems occur which may delay operations for more than one hour.

- (i) Open bypass valve at inlet point, close inlet valve at inlet point, and flush inlet hose to sea.
- (ii) Pumping seawater, open and close the valves in the following sequence. Do not close a valve until grout has ceased to issue from the valve.
- (iii) Open inlet valve at inlet point. Open outlet valve at outlet point. Close bypass valve at inlet point. Flush for 15 minutes using the outlet point to pump seawater. Repeat flushing for

15 minutes using the inlet point to pump seawater. Do not stop flushing until grout has ceased to issue.

- (iv) Inspect all valves and 'rake out' where necessary.
- (v) If, as a result of stoppage, the inlet hole becomes permanently blocked by grout, a new inlet hole should be cut in the member as close to the existing hole as possible but avoiding any solid grout. The location of solid grout can be determined by using ultrasonic techniques or, alternatively, by tapping the member with a hammer (a grouted section will sound more solid than an ungrouted flooded section). The new hole should be placed using the same procedures as the original hole.

4.2.2.13 Post Grouting Procedure

Flush Grout Lines

Immediately after satisfactory grouting, close inlet and outlet valves and flush the grout inlet lines (via bypass) and retrieve to surface.

'Feed Hose'

The 'feed' hose at the outlet point shall be attached to the leg using lashing material. Underwater tape will be wrapped around exposed inlets/outlets and weep holes to prevent ingress of seawater. The 'feed' hose may be removed after 24 hours if required.

4.3 Fatigue Details

At completion of the work the inlets and outlets which remain form stress raisers which must be checked against fatigue. Assuming that the holes have been cut in parent plate (not weld metal) in the brace, then a type 'C' S-N curve applies and a hole gives rise to a stress concentration factor of 3.0. At single sided closure welds without thickness transitions a SCF of 1.4 applies with a type 'F2' S-N curve. At double sided butt welds without thickness transitions a SCF of 1.3 applies with a type 'E' S-N curve.

Figure 4.8 illustrates the relative endurance of each of the three details described. It is clear that the grout inlet/outlets represent the worst case. The single sided and doubled sided weld cases will have been checked in detailed design, it is, therefore, necessary to additionally check the brace member for fatigue at the inlet/outlet points.

4.4 Construction Details

4.4.1 Grout Inlets/Outlets

A typical arrangement of a jig used to drill and tap holes in members on an offshore structure is depicted in Figure 4.9. This particular jig is intended to be held in place and react the drilling force by being strapped to the member. However, the jig could equally be held in place by a simple hydraulic grabber arm arrangement. The drill and tap are held against the member by turning the handle at the end of the threaded bar using either a diver or a ROV. It is possible to carry out the drilling and tapping with a single tool in a single operation.

4.4.2 Grout Bags

It is conceivable, in certain circumstances, that it may not be desirable to grout the whole length of the member. Such an occasion would be where additional weight of fill grout would distress the member. In such an event it is necessary to locally confine the grout and this is achieved by the use of grout bags.

Figure 4.10 illustrates the general arrangement of such an application which consists of the following stages:-

1. Cut 125mm x 100mm holes in member.
2. Dress holes to remove sharp edges, burrs etc.
3. Insert grout bags and tie off inlets.
4. Inflate grout bags with 'standard' grout mix.
5. Maintain recommended pressure whilst grout sets.
6. Wait 24 hours after grouting of bags before grouting the void created in the member

The grout bag producers have now developed a standard specification for the material as follows:-

The material is manufactured from yellow woven polypropylene with the following characteristics in a standard tensile test

Warp 310 Kgf per 5 cm width
Weft 175 Kgf per 5 cm width
Weight = 300 g/m²

The material is inert and is non degradable.

The material shall be protected at all times from prolonged exposure to direct sunlight.

All cutting of the material shall be by the 'hot-knife' method to prevent fraying of the seams and edges. Sewing thread shall be Polyamid Zwylon.

5. GROUT MIXES

This section describes the minimum technical requirements necessary for the grout constituent materials, mix design and quality control for grout filling of tubular members.

5.1 Design Requirements

All grouts to be used shall achieve a minimum compressive strength of 41.4 N/mm² at 28 days.

5.2 Grout Mix Proportions

All procedures in Section 4 are based on the grout mix given in Section 5.2.1. However the mix in Section 5.2.2 is equally acceptable, but produces a slightly less dense mix.

5.2.1 Oilwell Cement

The grout mix shall be as follows:-

Class 'B' or 'G' oilwell cement to API Specification 10 or equivalent	100 parts by weight
Water	34 parts by weight

Alternatively, sulphate resisting Portland Cement to specification ASTM C150 Type II may be submitted in the same proportions.

No admixtures shall be permitted.

The mix will produce a slurry with a theoretical specific gravity of 2.05 and a yield of 0.65 m³ per tonne of cement.

5.2.2 Dutch Encillite

The grout mix shall be as follows:-

Dutch Encillite (Dutch Portland Class B)	100 parts by weight
Water	39 parts by weight

No admixtures shall be permitted.

The mix will produce a slurry with theoretical specific gravity of 1.98 and a yield of 0.7 m³ per tonne of cement.

5.3 Materials

Manufacturer's Certificates of Quality with respect to the materials shall be obtained before use.

The cement shall be stored and transported in accordance with the manufacturer's instructions. The cement shall be kept free from moisture at all times and a careful inspection of all materials shall be made prior to their use to ensure their suitability for the work.

Potable water shall be used in preference to seawater if readily available on the platform. Seawater shall be clean, if used, and should be taken from the hydrant ringmain no earlier than one hour before mixing. The temperature of the water shall be in the range 4°C to 8°C.

All measures shall be taken to keep the cement and water cool prior to mixing. The measures proposed shall be subject to Client approval.

5.4 Grout Mixing

The grout shall be mixed using a continuous recirculating jet type mixer. The mixer type specified shall be subject to Client approval. An initial mix shall be made to line the mixer. This mix shall be discarded. Subsequent batches shall be used to grout the members. All batches shall be mixed for a minimum of two minutes.

5.5 Quality Control Requirements

5.5.1 Equipment

Calibration certificates are to be supplied for all relevant equipment.

5.5.2 Slurry Density Measurements

Measurement of slurry densities shall be made using a pressurised slurry density balance in the manner described in API Specification 10. Particular attention shall be paid to ensure that the external surfaces of the balance are cleaned and dried after filling and prior to balancing.

Grout mixes in accordance with Section 5.2.1 shall not be pumped until a specific gravity of 2.00 or greater is achieved. Grout mixes in accordance with section 5.2.2 shall achieve a specific gravity of 1.96. Slurry densities shall be checked immediately prior to pumping and throughout the grouting operations, sampling every batch mixed.

5.5.3 Cube Manufacture, Curing and Testing

Cubes shall be manufactured in accordance with Specification BS 1881 Part 108: 1970, or equivalent, with the exception that 75mm cubes shall be used.

The cubes shall be placed in a thermostatically controlled curing tank immediately after manufacture and cured at a temperature of $8^{\circ}\text{C} \pm 1^{\circ}\text{C}$ until removed for demolding or testing. Seawater shall be used in the cube curing/storage tanks.

Cubes may be demolded after 24 hours and returned to the curing tank. Cubes shall not spend more than 1 (one) hour out of the curing tank.

Cubes shall be prepared for testing, weighed, measured and crushed within 30 minutes of removal from the curing tank.

The cube age shall be measured from the time the cube enters the tank to the time it is crushed.

Each cube shall be crushed in accordance with the procedure given in API Specification 10, with the exception that the rate of loading will not exceed 14 N/mm^2 per minute.

Each cube shall be marked with a unique mark and this mark correlated with the jacket member number, time, date made and slurry density as measured by a pressurised slurry density balance.

5.5.4 Sampling and Testing Procedure for Each Member

Four (4 N^o) 75mm cubes shall be cast from the grout in the grout mixer at the start of the grouting operation after the minimum specific gravity is achieved.

Grouting operations shall continue until the density of the vented grout from the member achieves the required specific gravity as measured using the method described in Section 5.5.2. Once the specified grout density has been achieved from all vents, four (4 N^o) 75mm cubes shall be cast from the remainder of the grout in the mixer using the method described in Section 5.5.3.

In addition to the casting of eight cubes noted above, twenty two (22 N^o) 75mm cubes shall be cast during the grouting operation. Sampling shall be carried out at approximately equal intervals throughout the grouting operation.

Cubes shall be tested in accordance with the method described in Section 5.5.3. Three good cubes shall be tested at each of the following intervals:-

- 3 days
- 7 days

- 14 days
- 21 days

The remaining cubes, of which at least six shall be good, shall be tested at 28 days. Any cubes to be tested onshore can be packed in insulated containers for shipment, provided always that the curing regime is maintained.

For each grouted member, the following information shall be collated for the final report:-

- Member identification reference.
- Cube number and position in grouting sequence (eg. beginning, middle, end).
- Time and date of casting the cube.
- Time and date of testing the cube.
- Fluid grout density at time of casting.
- Weight and density of the grout cube.
- Failure load and cube strength.
- Average strength for cubes tested at the same time.

5.5.5 Transportation of Test Cubes

A period of three days shall elapse before the cubes can be made ready for transportation ashore.

Cubes should be demolded and each cube must be individually wrapped in hessian sacking or cloth and placed in a polythene bag. Fresh water should then be added to keep the cube moist during transit. The polythene bag must be then sealed to entrain the water. A label identifying the cube should then be securely attached to the bag.

When all the cubes have been wrapped, they should be packed in a sturdy container. If possible, they should be further cushioned by placing rags, or a similar packing material between individual cubes and around the sides of the container. Any voids remaining after the cubes have been packed should be filled with rags, and finally, a lid should be firmly attached to the container. Attach 'Fragile' packing labels to container.

The cubes should be transported ashore by the fastest possible means. Notification to the consignee must be made in advance in order that the cubes can be uplifted from their location and taken to the testing laboratory for

storage. On arrival at the laboratory the cubes shall be immediately placed in a curing tank at a temperature of $8^{\circ}\text{C} \pm 1^{\circ}\text{C}$ until removed for testing.

6. EQUIPMENT LISTS

Equipment requirements to install a grouted member repair are given below. Equipment related to diving support is not included.

Drilling and Tapping

- Drilling and Tapping Jig to cut 1½" - 2" diameter holes in tubulars underwater. (see Figure 4.10)

Grouting

- Continuous batching recirculating jet mixer able to deliver approximately 4 m³/hour of mixed grout.
- grout holding tank
- grout pump
- cement silo(s)
- 2" grout hose
- 2" ball valves and unions (quick connect/disconnect type).

Grout Laboratory

- Curing tank capable of sustaining 8°C + 1°C. Suitable for minimum 30 cubes.
- Pressurised mud balance to test grout slurry density in accordance with API Spec 10.
- 75 mm cube moulds in accordance with BS 1881 part 108:1970.
- Weighing scales
- Callipers for measuring cube dimensions
- Cube crushing machine, minimum 50 tonnes capacity.
- Crates and packing in which to transport cubes ashore.

7. ESTIMATED OFFSHORE DURATIONS

Offshore logs have been made available to MSL Engineering for a project involving grout filling of 2 horizontal members through drilled and tapped inlets and outlets. The following durations are based on this project and do not allow for weather downtime or mechanical breakdown.

Day 1

Setting up equipment.
Start drilling and tapping holes. (10 No total)
Make trial mix.

Day 2

Continue drill and tap.
Make up grout hoses.

Day 3

Complete drill and tap.
Deploy hoses to Member 1.
Leak test Member 1.

Day 4

Grout Member 1.
Recover hoses and fittings from Member 1.
Deploy hoses and fittings to Member 2.
Grout Member 2.

Day 5

Recover hoses and fittings from Member 2.
Demobilise dive team.

Day 6

Cube demoulding.
Demobilise grouting spread.

Day 7

Crush 3 day cubes.

Day 8

Demobilise grout team.

Specific tasks have the following durations:

- | | |
|--|--------------------|
| Drill and tap 10 NO 1½" inlets/outlets | - 30 hours diving |
| Leak test and grout Member 1 (18.5 m ³ grout) and recover lines | - 14½ hours diving |
| Leak test and grout Member 2 (11.2 m ³ grout) and recover lines | - 8 hours diving |

Work was executed by an air diving team with three divers in the water for a maximum of 180 minutes per dive.

For the two scenarios being addressed, time estimates have been developed using data derived from the reference offshore project.

Horizontal Member

Volume to be filled = 16m³

Day 1

Mobilise and set up equipment, make trial mix

Day2

Drill and tap 5 No inlets/outlets, 15 hours diving

Day 3

Deploy lines, grout member and recover lines, 15 hours diving

Day 4

Demobilise diving spread. Clean and service grouting spread. Demould cubes and prepare to transport ashore

Demobilise grouting spread

Day 6

Test 3 day cubes onshore

Day 10

Test 7 day cubes onshore

Day 31

Test 28 day cubes onshore

Inclined Member

Volume to be filled = 15 m³

Day 1

Mobilise and set up equipment, make trail mix

Day 2

Drill and tap or drill and clamp 2 No inlets/outlets, 6 hours diving
Deploy lines, grout member and recover lines, 12 hours diving

Day 3

Demobilise diving spread
Clean and service grouting spread
Demould cubes and prepare to transport ashore
Demobilise grouting spread

Day 5

Test 3 day cubes onshore

Day 9

Test 7 day cubes onshore

Day 30

Test 28 day cubes onshore

8. ESTIMATED OFFSHORE COSTS

Costs have been gathered from operators and diving companies for services related to installation of a grouted member strengthening scheme.

	North Sea	Gulf of Mexico (Preliminary)
Air diving support vessel	£20,000/day	\$15,000
Saturation diving support vessel	£30,000/day	\$40,000
Diving spread only	£15,000/day	\$10,000
Offshore grouting spread	£2,000/day	\$1,600/day
Cube testing onshore	£30/cube	\$30/cube
Cement	£70/T	
Drilling and tapping rig allow	£200/day	\$200/day

Unit costs of vessels and diving support are highly variable and depend on the availability at the time. If the work is combined with other operations then mob/demobs costs can be spread over a number of projects as well as there being a potential to negotiate a lower day rate on longer hire contracts. In light of the fluctuating nature of the major costs, the following cost estimates have been structured in such a way that the Operator can apply his own figures where they differ.

Timescales have been extracted from Section 7. In each case it is assumed that mobilisation to site and demobilisation require 2 days effort each.

The rates given for Gulf of Mexico operation above, are preliminary and, have not been confirmed. Therefore for this issue of the report estimates for Gulf of Mexico operation are on hold.

There is little difference in the costs of a horizontal or inclined member grouting operation, what small difference there is, is due to the reduced number of grout inlets fitted to the inclined member. Cost breakdowns for a North Sea operation are given in Table 8.1, and costs range from £121,500 for a job where a diving spread is supplied to work off the structure to £260,000 where a vessel supporting a full saturation diving spread is required.



C14IR015 Rev 0 December 1994

TABLES

Equipment	Use Days/No off	Air Diving Vessel Rate £/unit	Sat Diving Vessel £/unit	Diving Spread Only Rate £/unit	Air Diving Cost £	Sat Diving Cost £	Diving Spread Only Cost £
Diving vessel	8	20,000	30,000	15,000	160,000	240,000	120,000
Grouting spread	8	2,000	2,000	2,000	16,000	16,000	16,000
Drill & tap rig	8	200	200	200	1,600	1,600	1,600
Cube testing	30	30	30	30	900	900	900
Cement (per tonne)	25	70	70	70	1,750	1,750	1,750
				Total	180,250	260,250	140,250

HORIZONTAL MEMBER GROUTING NORTH SEA

Equipment	Use Days/No off	Air Diving Vessel Rate £/unit	Sat Diving Vessel £/unit	Diving Spread Only Rate £/unit	Air Diving Cost £	Sat Diving Cost £	Diving Spread Only Cost £
Diving vessel	7	20,000	30,000	15,000	140,000	210,000	105,000
Grouting spread	7	2,000	2,000	2,000	14,000	14,000	14,000
Cube testing	30	30	30	30	900	900	900
Cement (per tonne)	23	70	70	70	1,610	1,610	1,610
				Total	156,510	226,510	121,510

INCLINED MEMBER GROUTING NORTH SEA

TABLE 8.1 ESTIMATED COSTS FOR A GROUTED MEMBER REPAIR

C141R015 Rev 0 December 1994

MSL

FIGURES

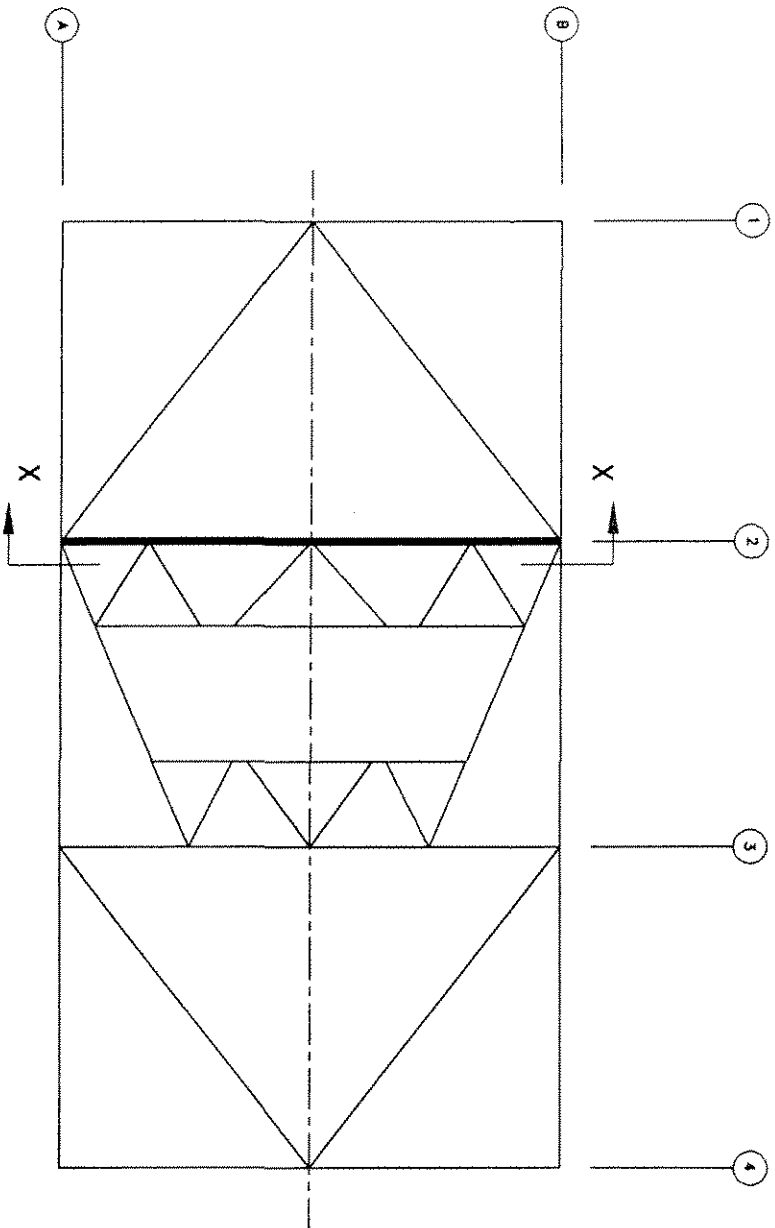

Figure 3.1 PLAN AT ELEVATION -12m LEVEL
SHOWING MEMBER TO BE GROUT-FILLED

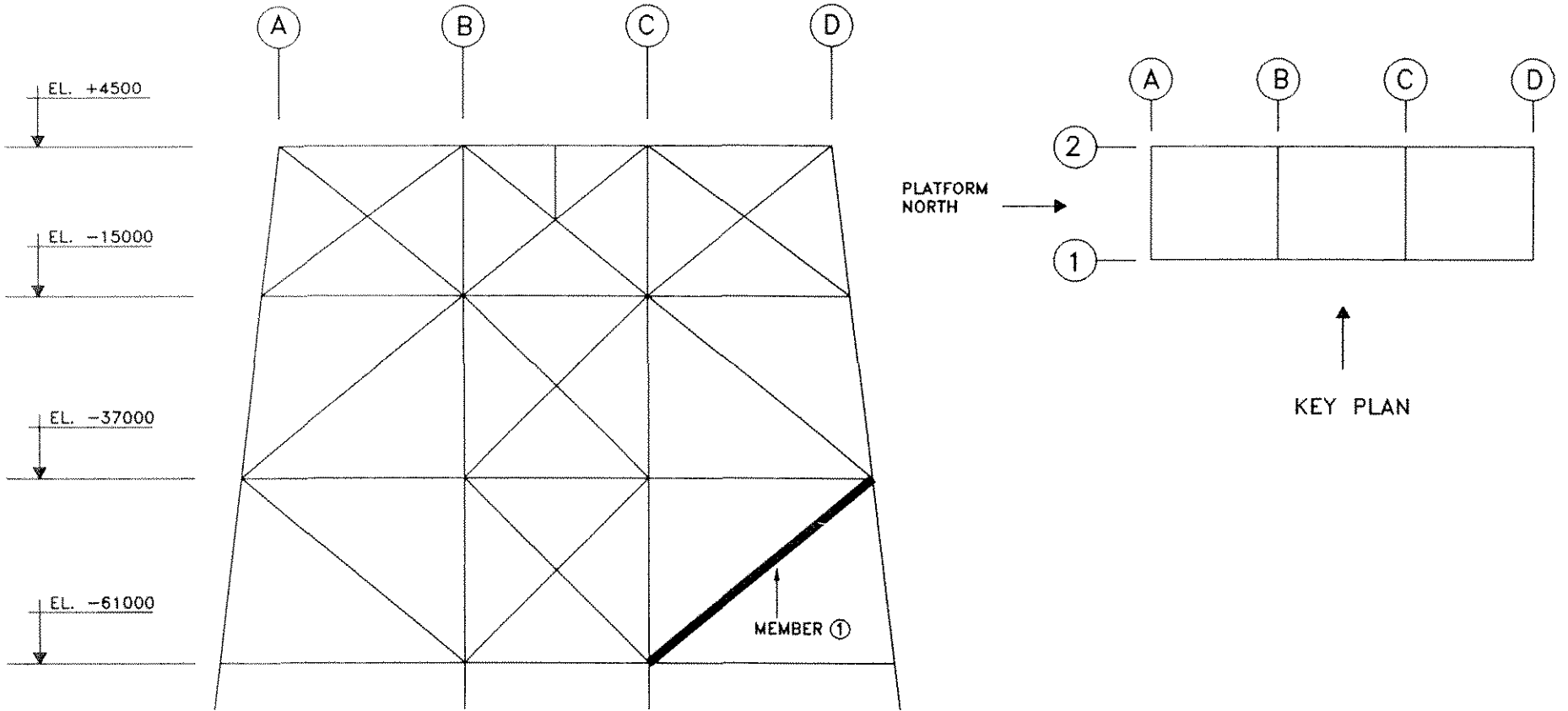

Figure 3.3 ELEVATION ON ROW 1

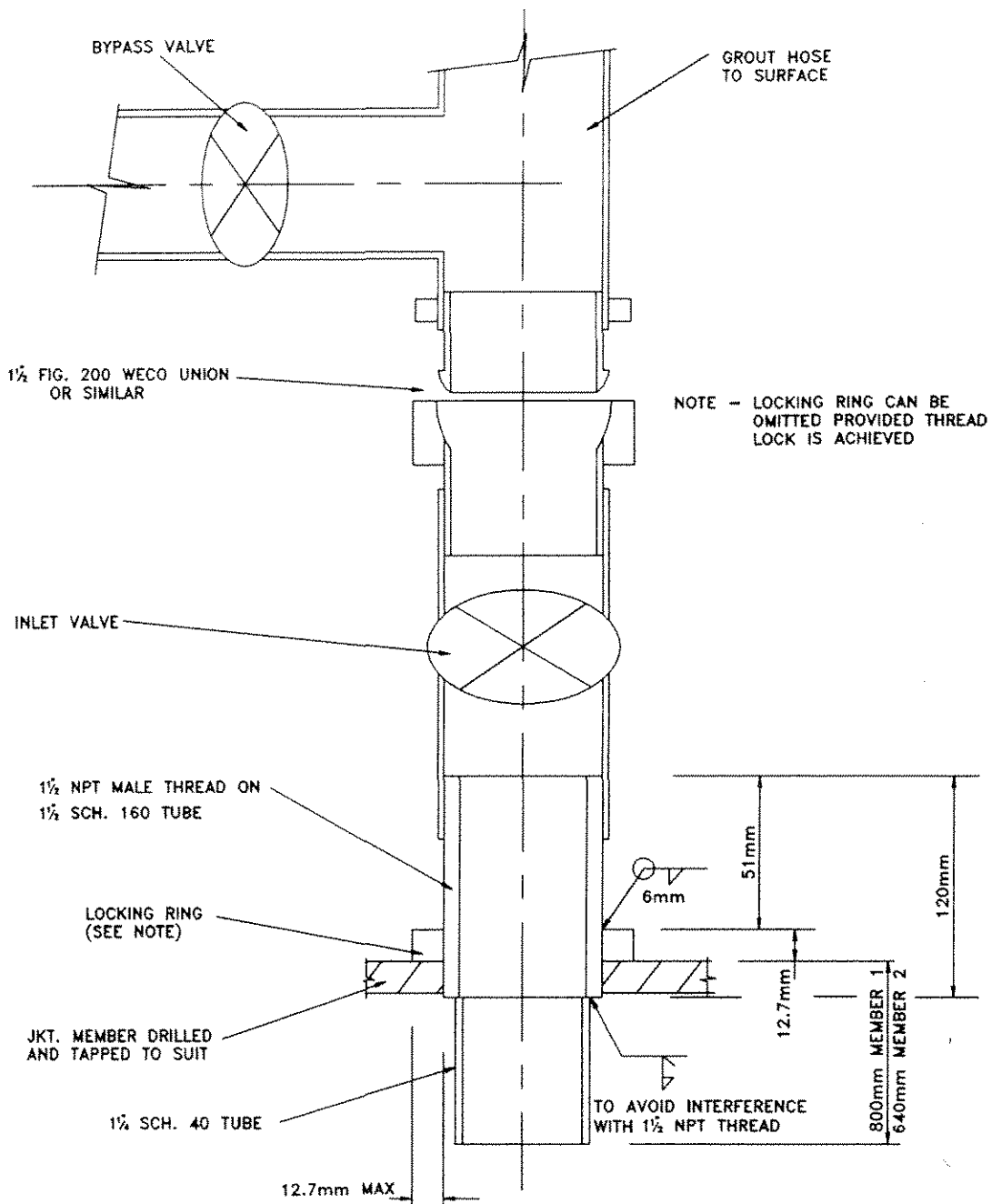
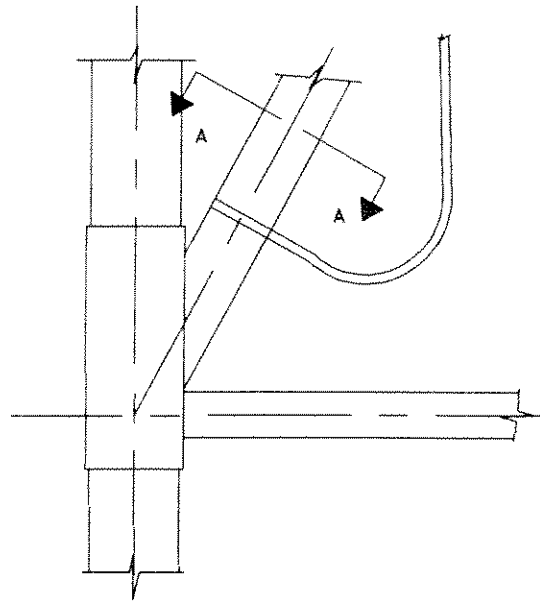

Figure 4.1 ARRANGEMENT OF GROUT INLET CONNECTIONS



ELEVATION

NOTE

INLETS TO BE PLACED AT LOWEST POINT ON MEMBER CIRCUMFERENCE EXCEPT THAT INLETS TO BE AT LEAST 300mm FROM ANY GIRTH WELD AND 150 mm FROM ANY LONGITUDINAL WELD

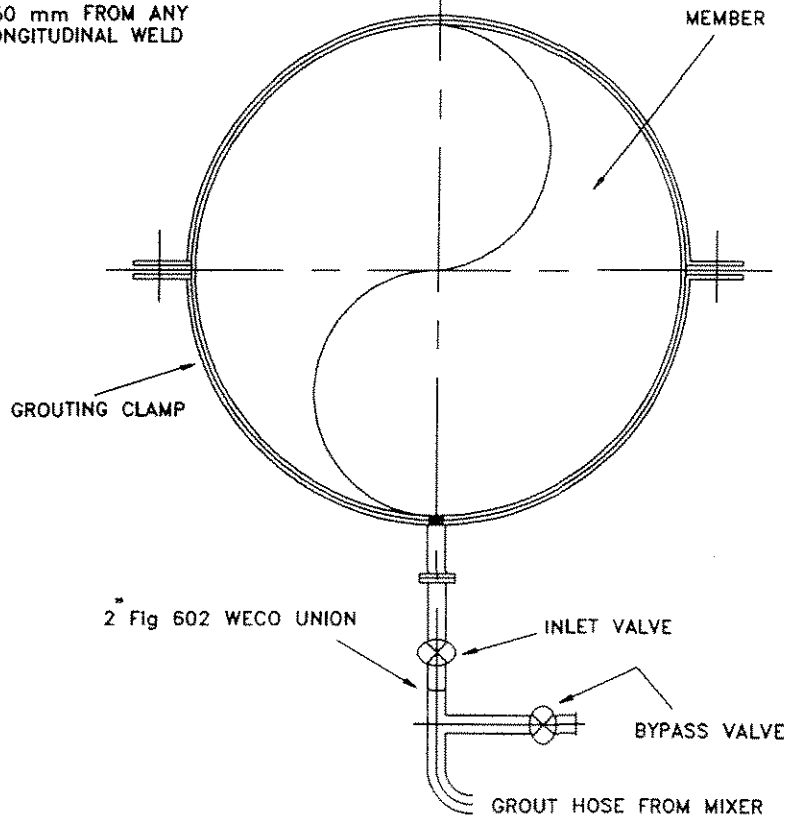

VIEW A-A

Figure 4.2 DETAIL OF INLET

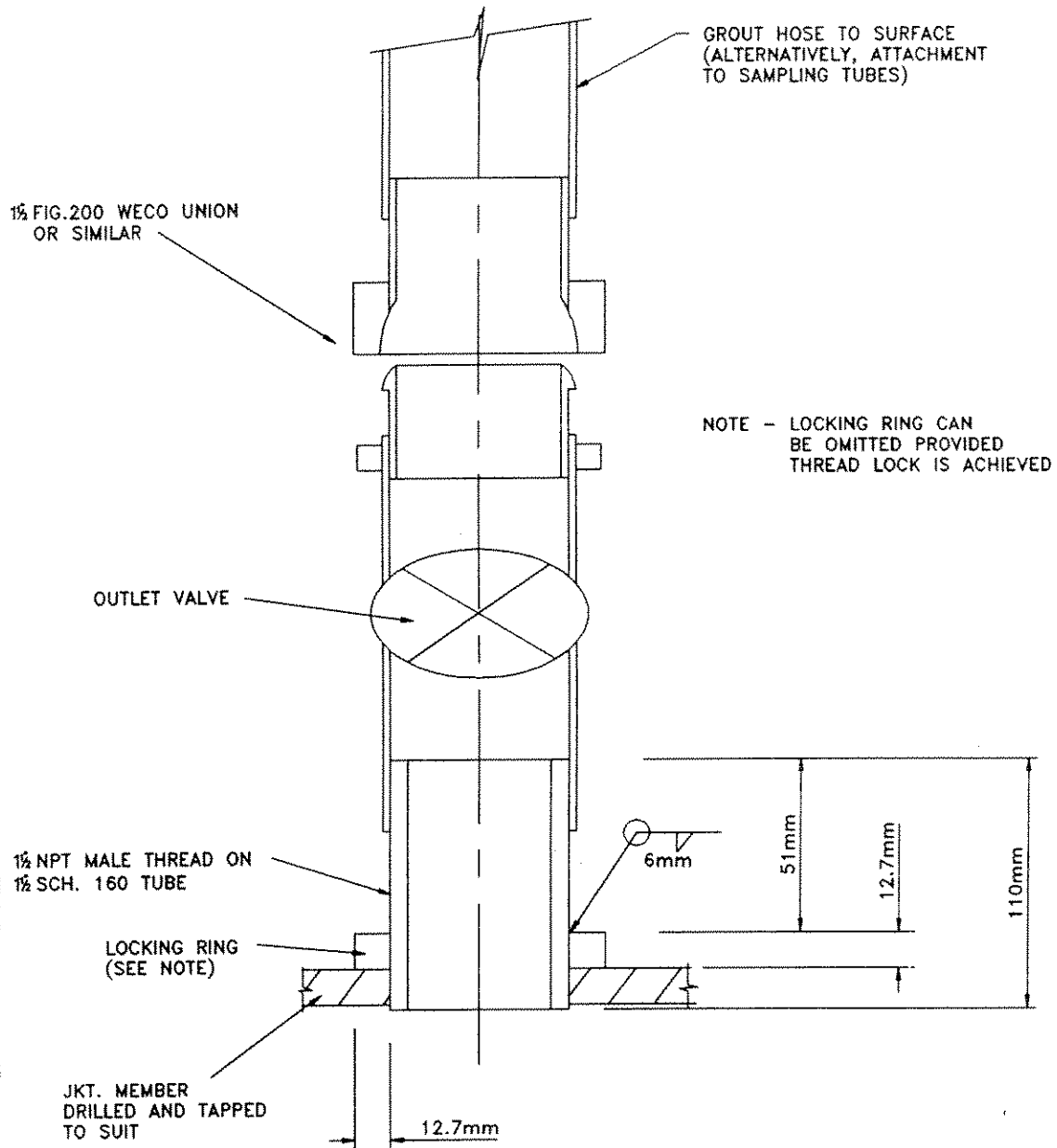

Figure 4.3 ARRANGEMENT OF GROUT OUTLET CONNECTIONS

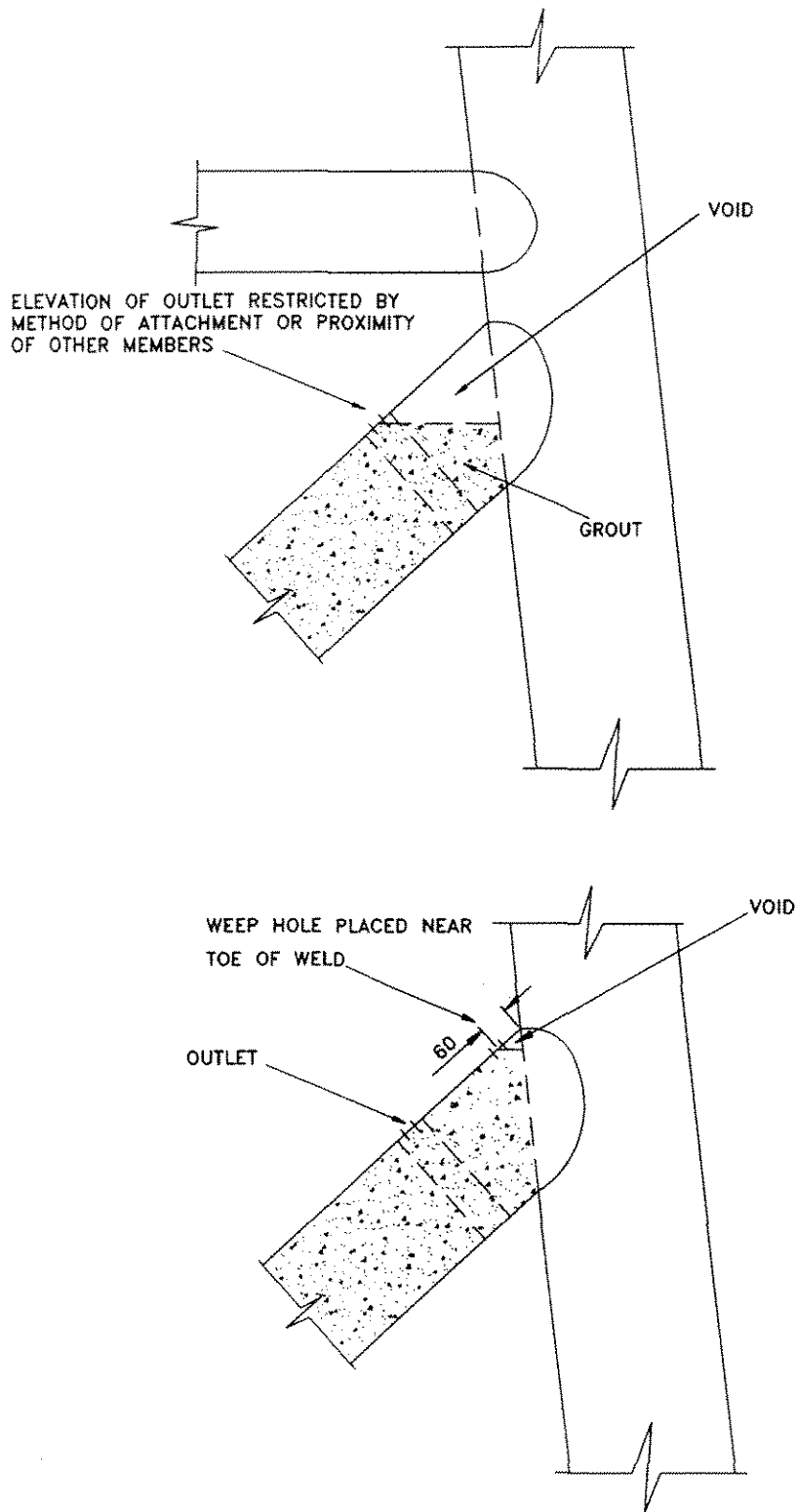

Figure 4.4 – OUTLET DETAILS

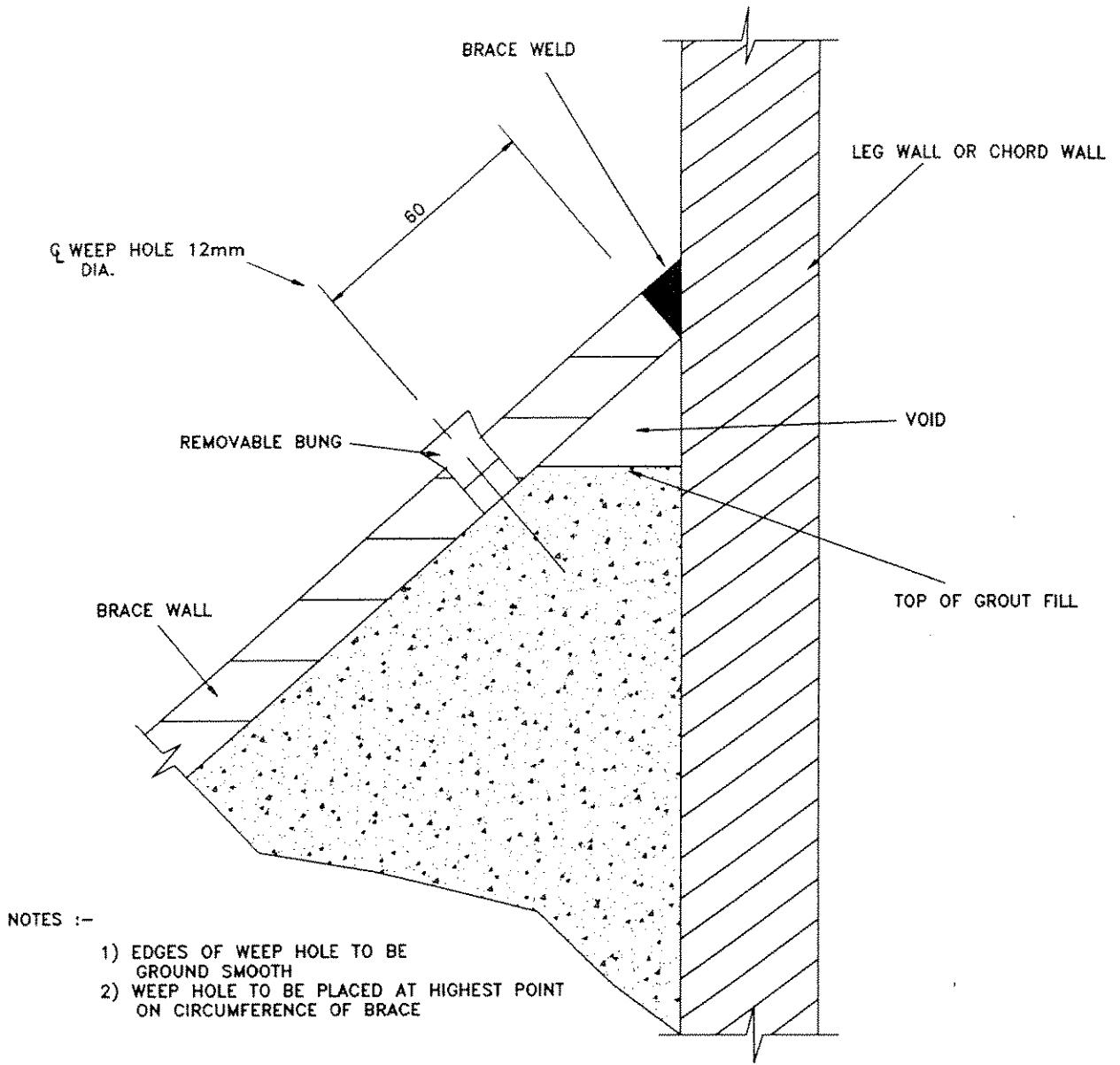
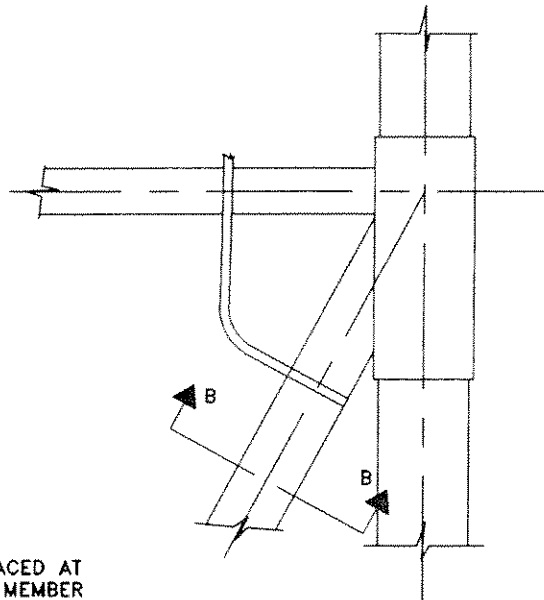

Figure 4.5 – WEEP HOLE DETAILS



ELEVATION

NOTE

OUTLETS TO BE PLACED AT HIGHEST POINT ON MEMBER CIRCUMFERENCE EXCEPT THAT OUTLETS TO BE AT LEAST 300mm FROM ANY GIRTH WELD AND 75 mm FROM ANY LONGITUDINAL WELD

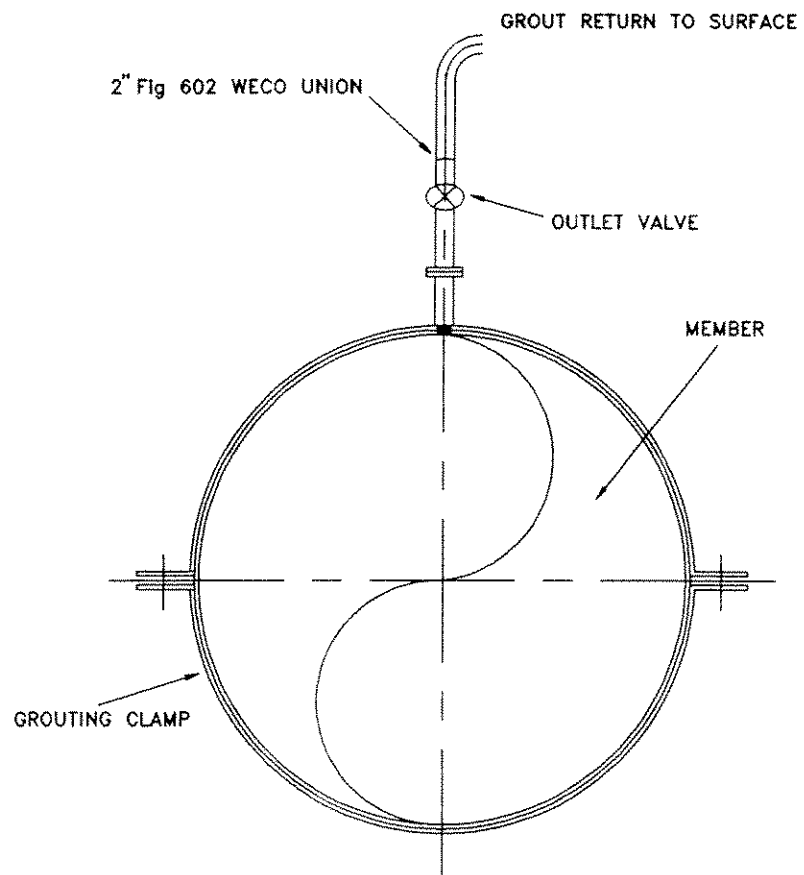

VIEW B-B

Figure 4.6 DETAIL OF OUTLET

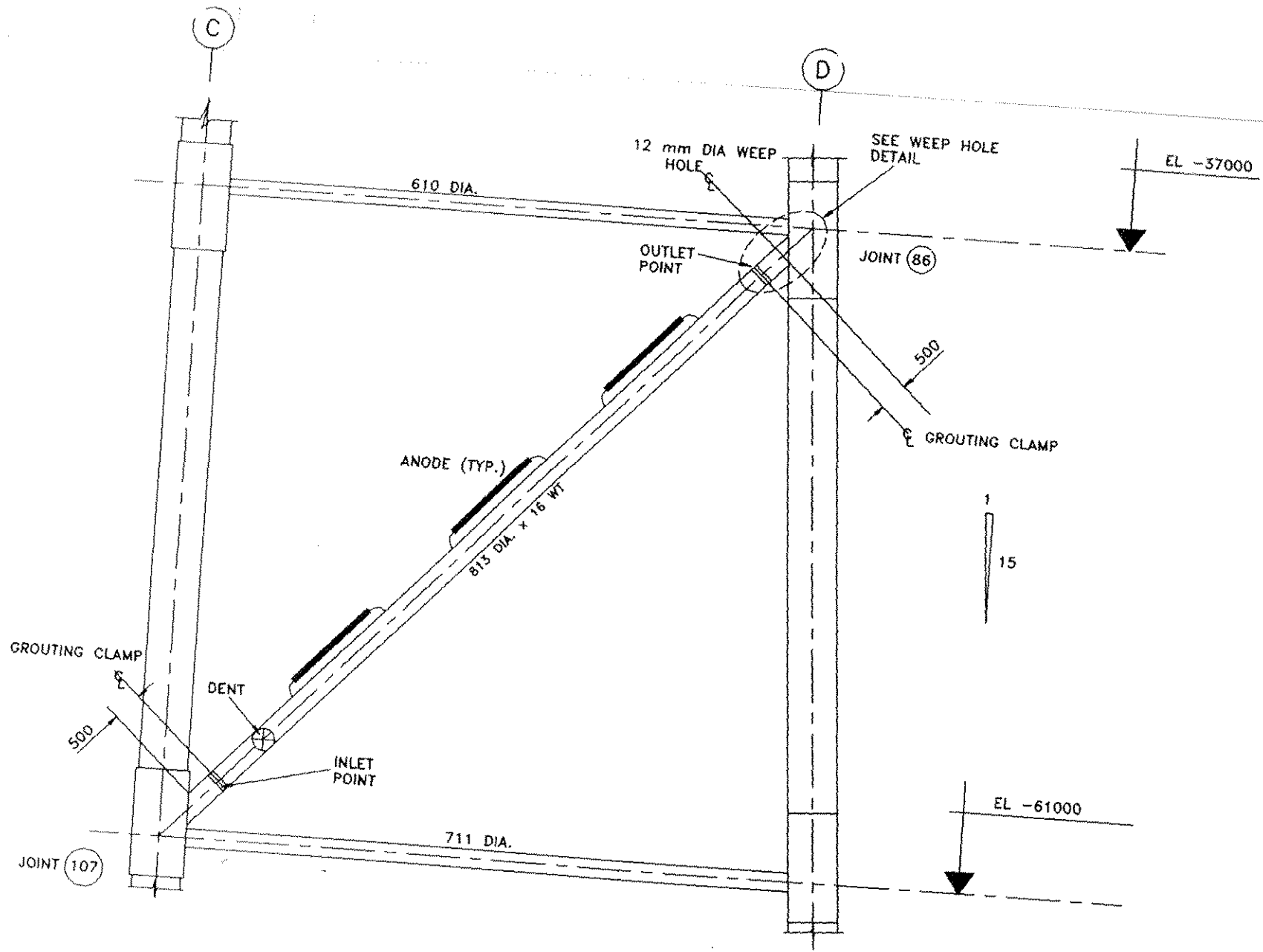

Figure 4.7 ELEVATION ON MEMBER 1

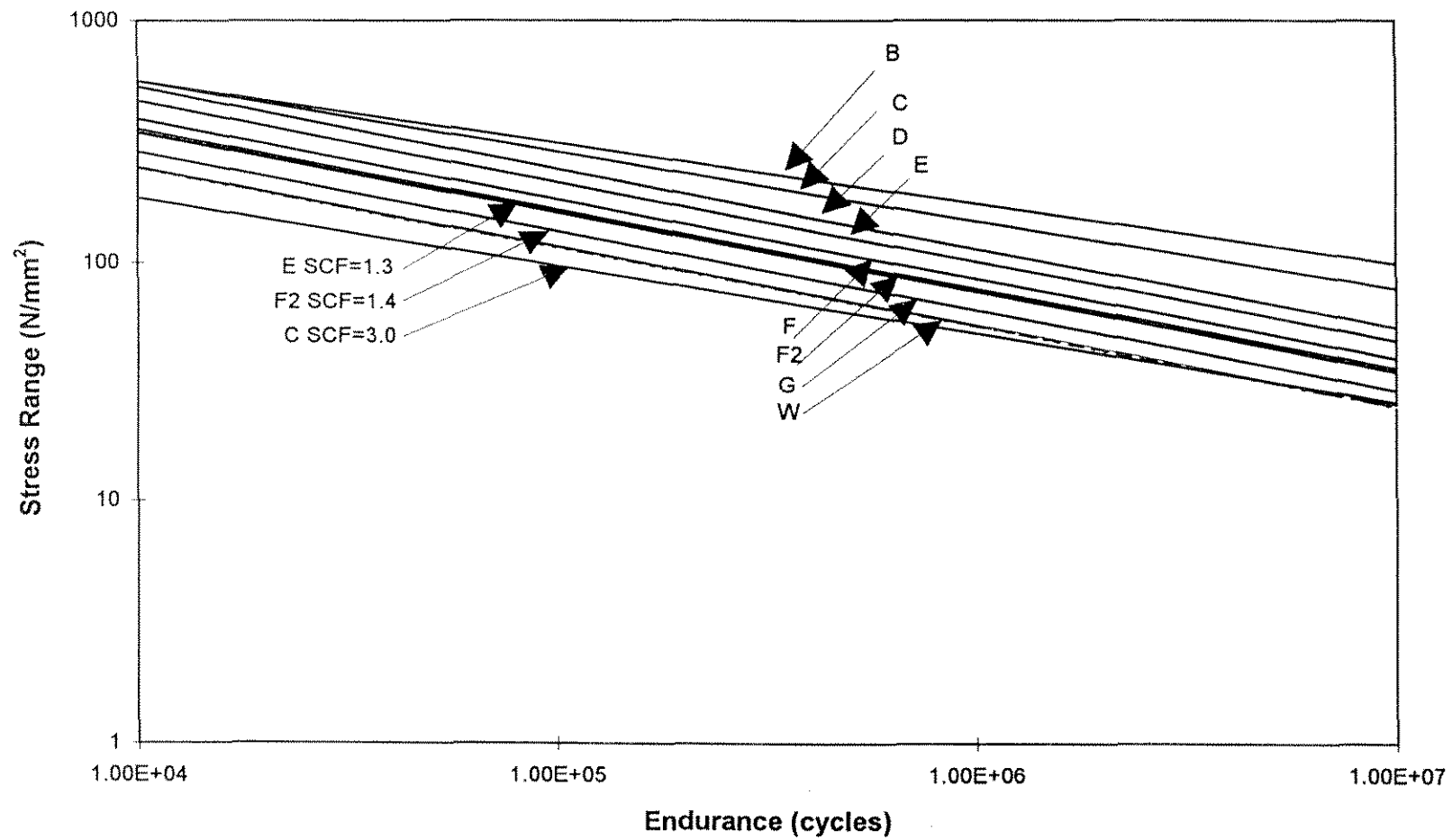

Figure 4.8 FATIGUE LIVES FOR HOLES AND BUTTWELDS IN MEMBERS

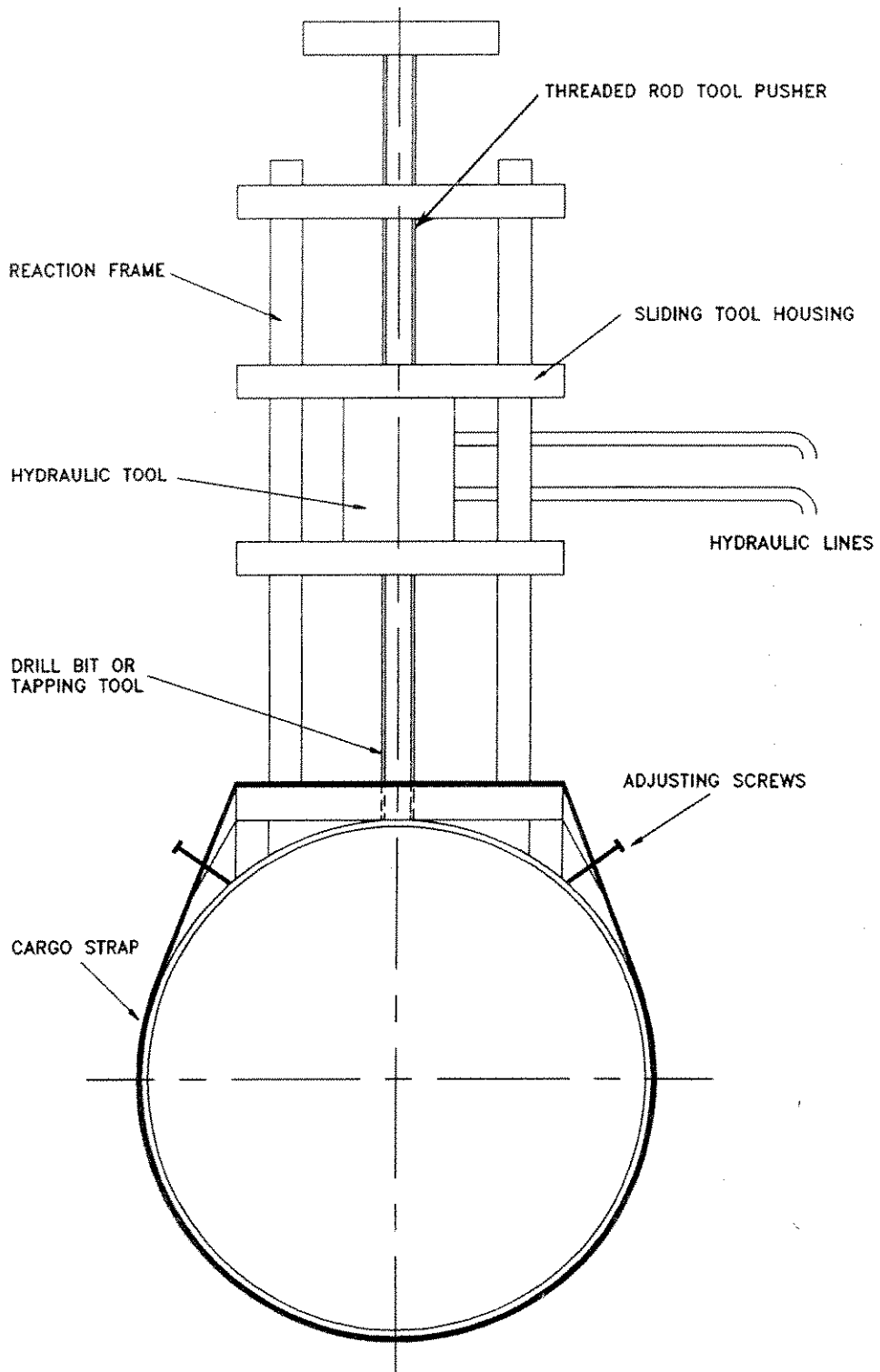

Figure 4.9 GENERAL ARRANGEMENT OF
UNDERWATER DRILLING / TAPPING TOOL

BAG INSTALLED VIA
125mm x 100mm
HOLE IN MEMBER

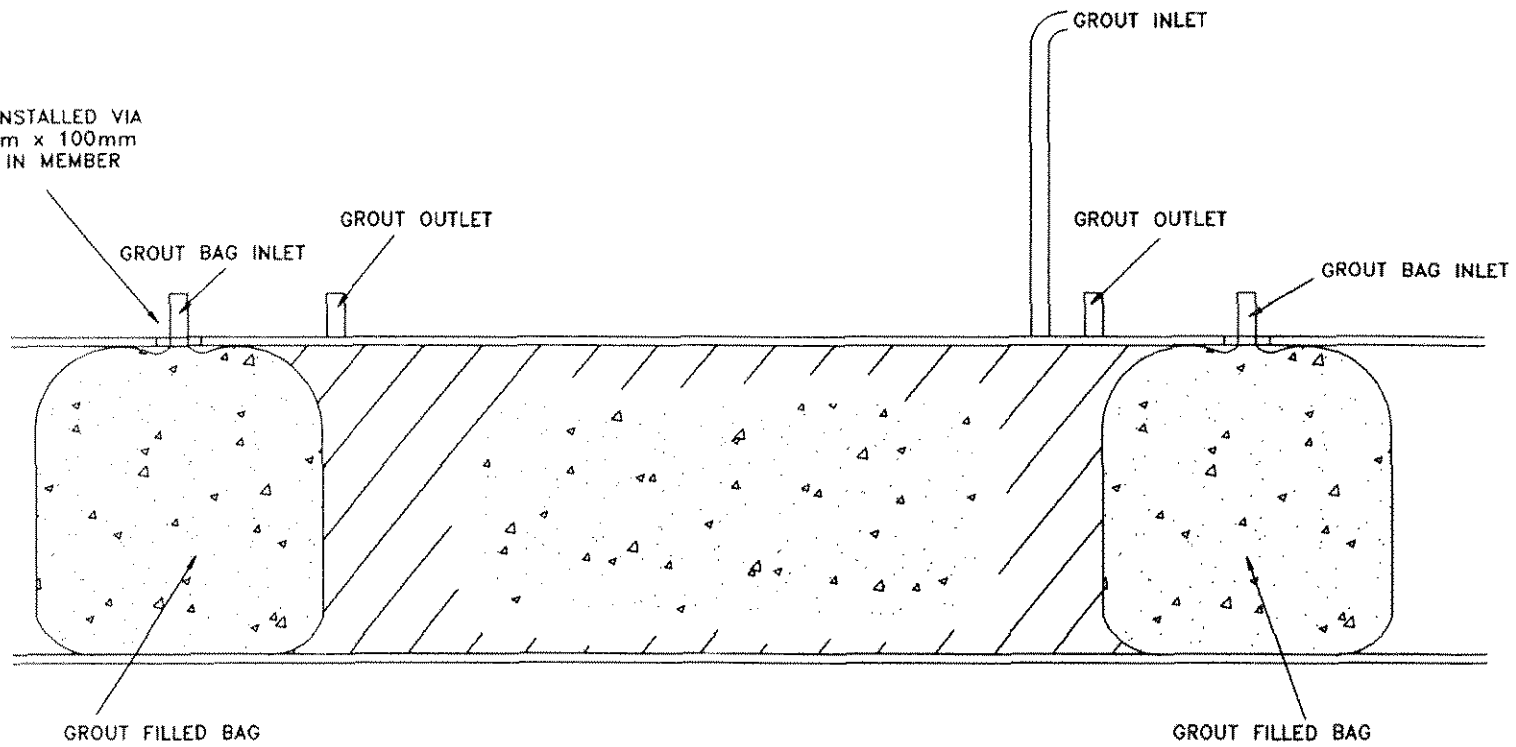

Figure 4.10 APPLICATION OF GROUT BAGS IN MEMBER FILLING

