

Worker Health and Safety on Offshore Wind Farms - Special Report 310

ISBN
978-0-309-26326-9

107 pages
8 1/2 x 11
2013

Transportation Research Board

 [More information](#)

 [Find similar titles](#)

 [Share this PDF](#)



Visit the National Academies Press online and register for...

- ✓ Instant access to free PDF downloads of titles from the
 - NATIONAL ACADEMY OF SCIENCES
 - NATIONAL ACADEMY OF ENGINEERING
 - INSTITUTE OF MEDICINE
 - NATIONAL RESEARCH COUNCIL
- ✓ 10% off print titles
- ✓ Custom notification of new releases in your field of interest
- ✓ Special offers and discounts

Distribution, posting, or copying of this PDF is strictly prohibited without written permission of the National Academies Press. Unless otherwise indicated, all materials in this PDF are copyrighted by the National Academy of Sciences. Request reprint permission for this book

Worker Health and Safety on Offshore Wind Farms



MARINE BOARD

Chair*: Michael S. Bruno, Stevens Institute of Technology, Hoboken, New Jersey

Chair**: Thomas M. Leschine, University of Washington, Seattle

Vice Chair: James C. Card (Vice Admiral, U.S. Coast Guard, retired),
Maritime Consultant, The Woodlands, Texas

Steven R. Barnum, Hydrographic Consultation Services, Suffolk, Virginia

Jerry A. Bridges, Bridges Group International, LLC

Mary R. Brooks, Dalhousie University, Halifax, Nova Scotia, Canada

Stephen M. Carmel, Maersk Line Limited, Norfolk, Virginia

Edward N. Comstock, Raytheon Company, Sudbury, Massachusetts

Elmer P. (Bud) Danenberger III,** Consultant, Reston, Virginia

Jeanne M. Grasso,** Blank Rome LLP, Washington, D.C.

Stephan T. Grilli, University of Rhode Island, Narragansett

Douglas J. Grubbs, Crescent River Port Pilots Association, Metairie, Louisiana

John M. Holmes, Port of Los Angeles, San Pedro, California

Donald Liu, NAE, Marine Consultant, Willis, Texas

Richard S. Mercier, Texas A&M University, College Station

Edmond J. Moran, Jr., Moran Towing Corporation, New Canaan, Connecticut

Ali Mosleh, University of Maryland, College Park

George Berryman Newton, Jr., U.S. Arctic Research Commission, Marstons
Mills, Massachusetts

Karlene H. Roberts, University of California, Berkeley (Emerita)

Peter K. Velez, Shell International Exploration and Production, Inc.,
Houston, Texas

John William Waggoner, HMS Global Maritime, New Albany, Indiana

*Term of service completed October 2012.

**Beginning November 2012.

TRANSPORTATION RESEARCH BOARD 2013 EXECUTIVE COMMITTEE OFFICERS

Chair: Deborah H. Butler, Executive Vice President, Planning, and CIO,
Norfolk Southern Corporation, Norfolk, Virginia

Vice Chair: Kirk T. Steudle, Director, Michigan Department of
Transportation, Lansing

Division Chair for NRC Oversight: Susan Hanson, Distinguished University
Professor Emerita, School of Geography, Clark University, Worcester,
Massachusetts

Executive Director: Robert E. Skinner, Jr., Transportation Research Board

Transportation Research Board Special Report 310

Subscriber Categories

Transportation Research Board Special Report 310

Safety and human factors, marine transportation

Subscriber Categories

Transportation Research Board publications are available by ordering individual publications directly from the TRB Business Office, through the Internet at www.TRB.org or national-academies.org/trb, or by annual subscription through organizational or individual affiliation with TRB. Affiliates and library subscribers are eligible for substantial discounts. For further information, contact the Transportation Research Board Business Office, 500 Fifth Street, NW, Washington, DC 20001 (Telephone 202-334-3213; fax 202-334-2519; or e-mail TRBsales@nas.edu). Printed in the United States of America.

Copyright 2013 by the National Academy of Sciences. All rights reserved.

NOTICE: The project that is the subject of this report was approved by the Governing Board of the National Research Council, whose members are drawn from the councils of the National Academy of Sciences, the National Academy of Engineering, and the Institute of Medicine. The members of the committee responsible for the report were chosen for their special competencies and with regard for appropriate balance.

NOTICE: The project that is the subject of this report was approved by the Governing Board of the National Research Council, whose members are drawn from the councils of the National Academy of Sciences, the National Academy of Engineering, and the Institute of Medicine. The members of the committee responsible for the report were chosen for their special competencies and with regard for appropriate balance.

This report has been reviewed by a group other than the authors according to the procedures approved by a Report Review Committee consisting of members of the National Academy of Sciences, the National Academy of Engineering, and the Institute of Medicine.

This study was sponsored by the Bureau of Safety and Environmental Enforcement of the U.S. Department of the Interior, the National Academy of Engineering, and the Institute of Medicine.

This study was sponsored by the Bureau of Safety and Environmental Enforcement of the U.S. Department of the Interior. *Cover photograph: Offshore Wind Services B.V., managed by Workships Contractors B.V. Used with permission.*

Typesetting by Circle Graphics

Library of Congress Cataloging-in-Publication Data

Library of Congress Cataloging-in-Publication Data

National Research Council (U.S.). Transportation Research Board. Committee on Offshore Wind Farm Worker Safety, author.
National Research Council (U.S.). Transportation Research Board. Committee on Worker Health and Safety on Offshore Wind Farms / Committee on Offshore Wind Farm Worker Safety, author.
Offshore wind farm worker safety. / Committee on Offshore Wind Farm Worker Safety.

Worker health and safety on offshore wind farms / Committee on Offshore Wind Farm Worker Safety. (Transportation research board special report ; 310)
Pages cm — (Transportation research board special report ; 310)
ISBN 978-0-309-16326-9

1. Offshore wind power plants—Employees—Health and hygiene—United States.

2. Offshore wind power plants—United States—Safety measures. 3. Offshore wind power plants—Safety regulations—United States. I. National Research Council (U.S.). Transportation Research Board. II. Title. III. Series: Special report (National Research Council (U.S.)). Transportation Research Board ; 310.

4. Offshore wind power plants—United States—Safety measures. 3. Offshore wind power plants—Safety regulations—United States. I. National Research Council (U.S.). Transportation Research Board. II. Title. III. Series: Special report (National Research Council (U.S.)). Transportation Research Board ; 310.

5. Offshore wind power plants—United States—Safety measures. 3. Offshore wind power plants—Safety regulations—United States. I. National Research Council (U.S.). Transportation Research Board. II. Title. III. Series: Special report (National Research Council (U.S.)). Transportation Research Board ; 310.

6. Offshore wind power plants—United States—Safety measures. 3. Offshore wind power plants—Safety regulations—United States. I. National Research Council (U.S.). Transportation Research Board. II. Title. III. Series: Special report (National Research Council (U.S.)). Transportation Research Board ; 310.

7. Offshore wind power plants—United States—Safety measures. 3. Offshore wind power plants—Safety regulations—United States. I. National Research Council (U.S.). Transportation Research Board. II. Title. III. Series: Special report (National Research Council (U.S.)). Transportation Research Board ; 310.

8. Offshore wind power plants—United States—Safety measures. 3. Offshore wind power plants—Safety regulations—United States. I. National Research Council (U.S.). Transportation Research Board. II. Title. III. Series: Special report (National Research Council (U.S.)). Transportation Research Board ; 310.

9. Offshore wind power plants—United States—Safety measures. 3. Offshore wind power plants—Safety regulations—United States. I. National Research Council (U.S.). Transportation Research Board. II. Title. III. Series: Special report (National Research Council (U.S.)). Transportation Research Board ; 310.

10. Offshore wind power plants—United States—Safety measures. 3. Offshore wind power plants—Safety regulations—United States. I. National Research Council (U.S.). Transportation Research Board. II. Title. III. Series: Special report (National Research Council (U.S.)). Transportation Research Board ; 310.

11. Offshore wind power plants—United States—Safety measures. 3. Offshore wind power plants—Safety regulations—United States. I. National Research Council (U.S.). Transportation Research Board. II. Title. III. Series: Special report (National Research Council (U.S.)). Transportation Research Board ; 310.

12. Offshore wind power plants—United States—Safety measures. 3. Offshore wind power plants—Safety regulations—United States. I. National Research Council (U.S.). Transportation Research Board. II. Title. III. Series: Special report (National Research Council (U.S.)). Transportation Research Board ; 310.

13. Offshore wind power plants—United States—Safety measures. 3. Offshore wind power plants—Safety regulations—United States. I. National Research Council (U.S.). Transportation Research Board. II. Title. III. Series: Special report (National Research Council (U.S.)). Transportation Research Board ; 310.

14. Offshore wind power plants—United States—Safety measures. 3. Offshore wind power plants—Safety regulations—United States. I. National Research Council (U.S.). Transportation Research Board. II. Title. III. Series: Special report (National Research Council (U.S.)). Transportation Research Board ; 310.

15. Offshore wind power plants—United States—Safety measures. 3. Offshore wind power plants—Safety regulations—United States. I. National Research Council (U.S.). Transportation Research Board. II. Title. III. Series: Special report (National Research Council (U.S.)). Transportation Research Board ; 310.

16. Offshore wind power plants—United States—Safety measures. 3. Offshore wind power plants—Safety regulations—United States. I. National Research Council (U.S.). Transportation Research Board. II. Title. III. Series: Special report (National Research Council (U.S.)). Transportation Research Board ; 310.

17. Offshore wind power plants—United States—Safety measures. 3. Offshore wind power plants—Safety regulations—United States. I. National Research Council (U.S.). Transportation Research Board. II. Title. III. Series: Special report (National Research Council (U.S.)). Transportation Research Board ; 310.

18. Offshore wind power plants—United States—Safety measures. 3. Offshore wind power plants—Safety regulations—United States. I. National Research Council (U.S.). Transportation Research Board. II. Title. III. Series: Special report (National Research Council (U.S.)). Transportation Research Board ; 310.

19. Offshore wind power plants—United States—Safety measures. 3. Offshore wind power plants—Safety regulations—United States. I. National Research Council (U.S.). Transportation Research Board. II. Title. III. Series: Special report (National Research Council (U.S.)). Transportation Research Board ; 310.

20. Offshore wind power plants—United States—Safety measures. 3. Offshore wind power plants—Safety regulations—United States. I. National Research Council (U.S.). Transportation Research Board. II. Title. III. Series: Special report (National Research Council (U.S.)). Transportation Research Board ; 310.

21. Offshore wind power plants—United States—Safety measures. 3. Offshore wind power plants—Safety regulations—United States. I. National Research Council (U.S.). Transportation Research Board. II. Title. III. Series: Special report (National Research Council (U.S.)). Transportation Research Board ; 310.

22. Offshore wind power plants—United States—Safety measures. 3. Offshore wind power plants—Safety regulations—United States. I. National Research Council (U.S.). Transportation Research Board. II. Title. III. Series: Special report (National Research Council (U.S.)). Transportation Research Board ; 310.

23. Offshore wind power plants—United States—Safety measures. 3. Offshore wind power plants—Safety regulations—United States. I. National Research Council (U.S.). Transportation Research Board. II. Title. III. Series: Special report (National Research Council (U.S.)). Transportation Research Board ; 310.

24. Offshore wind power plants—United States—Safety measures. 3. Offshore wind power plants—Safety regulations—United States. I. National Research Council (U.S.). Transportation Research Board. II. Title. III. Series: Special report (National Research Council (U.S.)). Transportation Research Board ; 310.

25. Offshore wind power plants—United States—Safety measures. 3. Offshore wind power plants—Safety regulations—United States. I. National Research Council (U.S.). Transportation Research Board. II. Title. III. Series: Special report (National Research Council (U.S.)). Transportation Research Board ; 310.

THE NATIONAL ACADEMIES

Advisers to the Nation on Science, Engineering, and Medicine

Preface

In April 2011, the Bureau of Ocean Energy Management, Regulation, and Enforcement (BOEMRE) had just received the results of a study by the Marine Board of the National Research Council (NRC) focusing on the structural safety of offshore wind turbines (see TRB 2011). By that time, the first offshore wind farms in the United States had been planned for areas along the East Coast, the Gulf of Mexico, and the Great Lakes. Therefore, BOEMRE felt a sense of urgency in meeting its mandate for enhancing and enforcing safety regulations. The agency's perception was that offshore wind farms would soon be under construction; that skilled workers would be required to build, operate, and repair them; and that health and safety rules would need to be in place to protect the workers. The rules governing this work would need to be equivalent to those regulating work on land-based wind farms and offshore oil and gas platforms.

By requiring an operator to submit a description of a safety management system (SMS), the U.S. Department of the Interior's (DOI's) Bureau of Ocean Energy Management (BOEM)—formerly BOEMRE—has preempted the Occupational Safety and Health Administration (OSHA) from enforcing its health and safety regulations. Although BOEM has jurisdiction over regulating all renewable energy development activities on the outer continental shelf (OCS) and requires an SMS, the agency recognized that the requirements are vague and need updating. In August 2011, BOEMRE (now BOEM) requested that the Marine Board conduct a study to assess the agency's approach for regulating the health and safety of wind farm workers on the OCS.

Appointed by NRC, the study committee consists of 11 members from industry, academia, and government with expertise in occupa-

SPECIAL REPORT 310

and the Occupational Safety and Health Administration (OSHA) and the Environmental Protection Agency (EPA). The committee also held public hearings in Washington, D.C., and in the field, to hear from workers, industry, and the general public. The committee's report is the result of these efforts.

The committee's report is the result of these efforts. The committee's report is the result of these efforts. The committee's report is the result of these efforts.

- David L. Michaels, Director, Occupational Safety and Health, U.S. Department of Labor
- Robert LaBelle, Acting Deputy Director, BSEE, DOI
- John Cushing, Senior Technical Advisor, BSEE, DOI
- Dean McKenzie, Chief, Health, Safety, and Environment, U.S. Department of Labor (Committee Liaison)
- Paul Shannon, Chief, Federal Energy Regulatory Commission

In approaching its charge, the committee initially needed to address the meaning of such terms as "hazard" and "risk," which the statement of task (see Box 1-2) used inconsistently. In an effort to clarify this situation, the committee first obtained insight from the occupational safety and health field, where a hazard is any source of potential damage, harm or adverse health effects on something or someone under certain conditions at work.³¹ The committee also recognized that other definitions of risk vary among disciplines; however, the committee ultimately adopted the concept of risk as the probability of injury or illness from a hazardous event.

During its deliberations, the committee identified hazards and recognized existing regulations, standards, and best practices (listed in Table 4-1) that could address each hazard. Some specific issues provided as examples in the statement of task—such as elevators in a marine environment and the inclusion of fire suppression systems—were suggested before the committee had a chance to identify the major safety issues involving offshore wind personnel. While these issues are a concern, they are not discussed in as much detail as other hazards. For example, the committee learned that elevators or service lifts may be less exposed to the corrosive marine environment and may present less of a maintenance hazard than previously thought. Also, the committee recognized that offshore wind turbines are usually unmanned and may require a review of maintenance and repair procedures.

The committee's report is the result of these efforts. The committee's report is the result of these efforts. The committee's report is the result of these efforts.

The committee's report is the result of these efforts. The committee's report is the result of these efforts. The committee's report is the result of these efforts.

The committee's report is the result of these efforts. The committee's report is the result of these efforts. The committee's report is the result of these efforts.

The committee's report is the result of these efforts. The committee's report is the result of these efforts. The committee's report is the result of these efforts.

The committee's report is the result of these efforts. The committee's report is the result of these efforts. The committee's report is the result of these efforts.

Rear Admiral Millard S. Firebaugh (U.S. Navy, retired), University of Maryland, College Park; Ralph Marshall, ExxonMobil; Roger L. McCarthy, McCarthy Engineering, Palo Alto, California; Melissa A. McDiarmid, University of Maryland School of Medicine; Kevin P. McSweeney, ABS Corporate Technology, Houston, Texas; Brian Naughton, New West Technologies, LLC, Washington, D.C.; John S. Spencer, National Transportation Safety Board (retired), Conroe, Texas; and David J. Wisch, Chevron Energy Technology Company, Houston, Texas.

Although these reviewers provided many constructive comments and suggestions, they were not asked to endorse the committee's findings or recommendations, nor did they see the final draft of the report before its release. The review was overseen by Robert A. Frosch, Harvard University, and by Susan Hanson, Clark University. Appointed by NRC, they were responsible for making certain that an independent examination of this report was carried out in accordance with institutional procedures and that all review comments were carefully considered. Responsibility for the final content of this report rests entirely with the authoring committee and the institution.

James C. Card, *Chair*
Committee on Offshore Wind Farm Worker Safety

REFERENCES

Abbreviation

TRB Transportation Research Board

TRB. 2011. *Special Report 305: Structural Integrity of Offshore Wind Turbines: Oversight of Design, Fabrication, and Installation*. Transportation Research Board of the National Academies, Washington, D.C. <http://www.trb.org/Publications/Blurbs/165263.aspx>.

TRB. 2012. *Special Report 309: Evaluating the Effectiveness of Offshore Safety and Environmental Management Systems*. Transportation Research Board of the National Academies, Washington, D.C. <http://www.trb.org/Publications/Blurbs/167249.aspx>.

Acronyms and Abbreviations

Acronyms and abbreviations used in the report are listed below.

ABS	American Bureau of Shipping
ACP	Alternative Compliance Program
ADCI	Association of Diving Contractors International, Inc.
AIHA	American Industrial Hygiene Association
ALARP	as low as reasonably practicable
ANSI	American National Standards Institute
API	American Petroleum Institute
ASSE	American Society of Safety Engineers
ASTM	American Society for Testing and Materials (now known as ASTM International)
AWEA	American Wind Energy Association
BAST	best available and safest technology
BLS	Bureau of Labor Statistics
BOEM	Bureau of Ocean Energy Management (after October 1, 2011)
BOEMRE	Bureau of Ocean Energy Management, Regulation, and Enforcement (May 19, 2010, to October 1, 2011)
BSEE	Bureau of Safety and Environmental Enforcement (after October 1, 2011)
BWEA	British Wind Energy Association (RenewableUK since 2004)
CFR	Code of Federal Regulations
COP	construction and operations plan
CVA	certified verification agent
CZMA	Coastal Zone Management Act of 1972

DNV	Det Norske Veritas
DOE	U.S. Department of Energy
DOI	U.S. Department of the Interior
EA	environmental assessment
EAP	emergency action plan
EEP	emergency evacuation plan
EIS	environmental impact statement
EPAct	Energy Policy Act of 2005
EPRI	Electric Power Research Institute
ERCoP	emergency response cooperation plan
ERP	emergency response plan
ESP	electric service platform
EWEA	European Wind Energy Association
FDR	facility design report
FERC	Federal Energy Regulatory Commission
FIR	fabrication and installation report
FR	<i>Federal Register</i>
GAP	general activities plan
GL	Germanischer Lloyd
GOM	Gulf of Mexico
GW	gigawatts
GWEC	Global Wind Energy Council
GWO	Global Wind Organisation
HFE	human factors engineering
HSE	Health and Safety Executive (United Kingdom)
IEC	International Electrotechnical Commission
ILO	International Labour Organization
IMCA	International Marine Contractors Association
IMO	International Maritime Organization
INC	incident of noncompliance
ISM	International Safety Management
ISO	International Organization for Standardization
KPI	key performance indicator
MCA	Maritime and Coastguard Agency
MMS	Minerals Management Service (before May 19, 2010)
MOA	memorandum of agreement

MOC	management of change
MOU	memorandum of understanding
MW	megawatts
NAE	National Academy of Engineering
NAICS	North American Industry Classification System
NEPA	National Environmental Policy Act
NFPA	National Fire Protection Association
NIOSH	National Institute for Occupational Safety and Health
NOTLC	National Offshore Training and Learning Center
NRC	National Research Council
NREL	National Renewable Energy Laboratory
NTL	notice to lessees
NVIC	Navigation and Vessel Inspection Circular
OCS	outer continental shelf
OCSLA	Outer Continental Shelf Lands Act of 1953
OHSAS	Occupational Health and Safety Assessment Series
ONRR	Office of Natural Resources Revenue (collection arm of former MMS, after October 1, 2010)
OORP	Office of Offshore Regulatory Programs
OREI	offshore renewable energy installation
OREP	Office of Renewable Energy Programs
ORM	operational risk management
OSHA	Occupational Safety and Health Administration
OWA	offshore wind accelerator
PINC	potential incident of noncompliance
PPE	personal protective equipment
PSM	process safety management
PtD	prevention through design
RP	Recommended Practice
RUK	RenewableUK (BWEA before 2004)
SAP	site assessment plan
SCADA	supervisory control and data acquisition
SEMP	safety and environmental management program
SEMS	safety and environmental management system
SIMOPS	simultaneous operations
SMS	safety management system

SOLAS	Safety of Life at Sea
TA&R	Technology Assessment and Research program
TRB	Transportation Research Board
TSMS	towing safety management system
USACE	United States Army Corps of Engineers
USCG	United States Coast Guard
USCOP	United States Commission on Ocean Policy
USDON	U.S. Department of the Navy
Z-PINC	personal safety potential incident of noncompliance

Contents

Executive Summary	1
1 Introduction	5
Study Objective and Charge	13
Organization of This Report	17
2 Hazards of Wind Farms	19
Wind Energy Turbines	19
Wind Farms	23
Summary Discussion	41
3 Jurisdiction over and Regulation of Worker Health and Safety	44
Relevant Federal Agencies	45
Federal Jurisdiction for Wind Farm Worker Health and Safety	64
Other Federal Agencies	66
State OSHA Programs and Regulations in Nonfederal Waters	68
Regulatory Approaches: Prescriptive and Goal-Based Worker Health and Safety Guidance from Other Sources	72
Summary Discussion	78

4 Regulations and Best Practices Addressing Unique Offshore Wind Farm Worker Safety and Health Hazards	83
Hazards on Wind Farms	84
Hazards Unique to Offshore Wind Farms	90
Summary Discussion	105
5 Enhancing Health and Safety Through Safety Management Systems and Design	108
Safety Management Systems	108
BOEM’s SMS Regulations	109
Important Elements for SMSs	111
Safety and Environmental Management System	119
Factors That Shape and Support SMSs	122
Role of Design in Worker Health and Safety	133
Summary Discussion	136
6 Findings and Recommendations	139
Study Committee Biographical Information	152

Executive Summary

The United States holds a large amount of untapped wind energy, both land-based and offshore. The strongest and most consistent winds are either offshore or in rural areas, far from population centers that could benefit from the electricity produced. As of December 31, 2012, the United States had more than 60,000 megawatts of installed wind capacity—second only to China—all of it from land-based wind farms. Offshore wind development would supply energy to nearby population centers, especially on the East Coast. Yet the United States has no offshore turbines installed; many European nations have developed dozens of offshore wind farms over the past 15 years.

Congress passed the Energy Policy Act of 2005, which authorized the Secretary of the U.S. Department of the Interior (DOI) to regulate renewable energy sources on the outer continental shelf (OCS). Initially, the Minerals Management Service (MMS) had responsibility for essential regulations and for implementing this new authority, in addition to regulating oil and gas development. In April 2010, MMS was reorganized (see Chapter 3), and previously coexisting functions were separated: resource development and energy management are now administered by the Bureau of Ocean Energy Management (BOEM), and health, safety, and environmental enforcement for offshore oil and gas is now administered by the Bureau of Safety and Environmental Enforcement (BSEE). The regulation of renewable energy is an exception to this organizational structure. DOI issued its final regulations in 30 CFR 585, which gave BOEM authority to regulate all renewable energy development activities on the OCS. The agency still needed to provide guidance in many areas of offshore wind development, including ensuring the health and safety of offshore wind workers.

In August 2011, DOI requested that the Marine Board of the National Research Council assess its approach for regulating the health and safety of wind farm workers on the OCS. The committee's three main tasks were as follows:

- Identify unique risks to worker health and safety on wind farms, as compared with oil and gas operations on the OCS;
- Identify any gaps or overlaps in jurisdictional authority; and
- Evaluate the adequacy of existing regulations and recommend enhancements to regulations for worker health and safety on OCS wind farms.

Although the federal government has regulated the production of offshore oil and gas for decades, it has no experience with offshore wind farms. Land-based and offshore wind development share many of the same tasks and hazards; in fact, once a technician is inside a wind turbine, most tasks are exactly the same. However, the challenge of working on and from vessels and in and over the water with massive offshore wind turbine equipment introduces additional hazards and different risks (see Chapters 2 and 4). The oil and gas and wind industries share most of these offshore hazards, but overall, the risk associated with oil and gas hazards is greater than that associated with offshore wind. In this context, workplace “risk” is viewed as the product of the probability and the consequence of a hazardous event. The oil and gas industry works with a more volatile product, so the risk of explosion or fire on offshore platforms is greater than on offshore wind turbines.

The Occupational Safety and Health Administration (OSHA) and the state programs, operating with OSHA oversight, normally have jurisdiction over private-sector worker health and safety regulations in the United States, including those applicable to the OCS. However, as established by Section 4(b)(1) of the Occupational Safety and Health Act, BOEM's intention to enforce worker health and safety regulations for wind energy by requiring the lessee to submit a description of a safety management system (SMS) has preempted OSHA from enforcing its regulations on the OCS, while the United States Coast Guard (USCG) has declared itself a cooperating agency for renewable energy activities. OSHA does regulate health and safety for land-based wind farms and has indicated that it will regulate offshore wind farms in state waters within

3 nautical miles and on the Great Lakes. BOEM will regulate worker health and safety for offshore wind farms on the OCS, although during committee deliberations, the sponsor reported that BSEE is expected to obtain authority to conduct health and safety compliance inspections for offshore renewable energy facilities by 2014. BOEM has jurisdiction, but its SMS requirements are unclear and incomplete. While the committee is not in a position to recommend a model SMS standard or guideline, it believes that a well-developed SMS, supplemented by details governing the control of specific hazards, is an important mechanism that allows an organization to improve its health and safety performance continually.

The committee has also examined the adequacy of DOI regulations and offers recommendations for enhancing them. The committee agrees that DOI should separate the energy management and health and safety compliance functions between BOEM and BSEE, as it has for offshore oil and gas. To enhance the SMS requirement for offshore wind, BOEM, with the help of stakeholders, should undertake rulemaking and adopt a full SMS rule at a level of detail that includes the baseline elements identified in Chapter 5 of this report or at a level comparable with that of the safety and environmental management system (SEMS) for the oil and gas industry. Moreover, BOEM should investigate the appropriateness of adapting SEMS for offshore wind on the basis of risk and of applying many of the recommendations from a recent 2012 Marine Board study (see Chapter 5). Any enhanced SMS rule should require the use of human factors engineering elements in the design process and should encompass all activities that the lessee and its contractors undertake. In addition, an enhanced SMS and a positive safety culture are closely linked: the SMS must consider all possible safety factors, while the safety culture will shape how an SMS is expressed within an organization.

In collaboration with other regulatory agencies and industry stakeholders, BOEM should lead development and implementation of a comprehensive health and safety program for workers on offshore wind farms. Through new or updated memoranda of understanding with OSHA and USCG, BOEM should clearly define roles and responsibilities and indicate which standards could apply for all phases of wind

farm development regardless of jurisdiction. With the help of stakeholders, BOEM should support the development of guidelines and recommended practices that could be used as guidance documents or adopted by reference. An enhanced SMS is an effective approach that ensures worker health and safety on offshore wind farms. It places the responsibility for controlling hazards on industry yet allows for technological changes and continued industry development.

Introduction

Global installed wind capacity from onshore and offshore sources increased from 7,600 megawatts (MW) at the end of 1997 to more than 282,000 MW at the end of 2012. Of the total, approximately 21 percent (60,007 MW) is installed within the United States (GWEC 2013), all of it onshore—the world’s second-highest wind turbine¹ generating capacity (GWEC 2013). Yet the United States has vast untapped wind energy resources: estimates of potential U.S. onshore “installed capacity” exceed 10 million MW.² In addition, potential offshore wind resources in U.S. coastal and Great Lakes waters are conservatively estimated at more than 2 million MW.³ Offshore wind could help the United States provide energy to coastal cities, where much of the nation’s population and electricity demand lie (NREL 2012).

Nevertheless, no offshore wind turbines have been installed in U.S. waters as of December 2012. Development of offshore wind farms⁴ is more advanced in Europe. Countries such as Denmark, Germany, Norway, and the United Kingdom already produce electricity offshore, with an installed capacity of more than 4,900 MW (EWEA 2013).⁵

¹ A wind turbine converts the energy of moving air into electricity.

² http://www.windpoweringamerica.gov/docs/wind_potential_80m_30percent.xls. “Installed capacity” is the potential megawatts of rated gross capacity that could be installed on available windy land areas (after exclusions) in all 50 states.

³ Exclusions include restrictions due to competing uses and environmentally sensitive areas. See <http://www.nrel.gov/docs/fy12osti/49222.pdf>.

⁴ Wind farms consist of one or more independently operating wind turbines that generate power and are connected to an electrical substation that transfers the power to the grid.

⁵ As of December 31, 2012, global cumulative offshore installed capacity exceeded 5,400 MW (GWEC 2013).

Through the Energy Policy Act of 2005, Congress authorized the Secretary of the U.S. Department of the Interior (DOI) to grant leases for activity that involves the production, transportation, or transmission of energy on the outer continental shelf (OCS) lands from sources other than gas and oil.⁶ In April 2009, the President and the Secretary of the Interior announced the final regulations for the OCS Renewable Energy Program, which defined the regulatory process and provided a framework for “leases, easements, and rights-of-way” for activities promoting the safe and environmentally responsible production and transmission of energy on the OCS from sources other than oil and natural gas (*Federal Register* 2009).⁷ In November 2010, the Secretary of the Interior announced the “Smart from the Start” wind energy initiative for the Atlantic OCS “to facilitate siting, leasing, and construction of new projects, spurring the rapid and responsible development of this abundant renewable resource”⁸ and to improve coordination with local, state, and federal partners in the wind development process. The initiative encouraged an accelerated process for offshore wind development, with a goal of issuing leases in 2011 and 2012. To support this rapidly evolving process, the federal government needed to provide timely guidance in many areas of offshore wind development, especially in ensuring the health and safety of offshore workers.

Working offshore in a marine environment is challenging and introduces multiple hazards.⁹ Weather conditions can be harsh and change constantly. European offshore wind operations already face such hazards as transfers to and from turbine platforms from vessels in shifting seas and injuries associated with dropped objects or with crane operations and suspended loads. Assembling sections of a wind turbine offshore can

⁶ As discussed in Chapter 3, the Secretary of the Interior delegated to the Minerals Management Service (MMS) the new authority that was conferred by the Energy Policy Act of 2005. In June 2010, MMS was renamed the Bureau of Ocean Energy Management, Regulation, and Enforcement (BOEMRE). On October 1, 2011, DOI reorganized BOEMRE and established two new, independent bureaus—the Bureau of Safety and Environmental Enforcement and the Bureau of Ocean Energy Management.

⁷ <http://www.boem.gov/BOEM-Newsroom/Press-Releases/2009/press0422.aspx>.

⁸ <http://www.doi.gov/news/pressreleases/Salazar-Launches-Smart-from-the-Start-Initiative-to-Speed-Offshore-Wind-Energy-Development-off-the-Atlantic-Coast.cfm>.

⁹ A hazard “is any source of potential damage, harm or adverse health effects on something or someone under certain conditions at work”; see http://www.ccohs.ca/oshanswers/hsprograms/hazard_risk.html.

TABLE 1-1 Growth in Rotor Diameter and Capacity of Offshore Wind Turbines, 1997–2020

Year	Capacity (MW)	Approximate Rotor Diameter (m)
1997	0.5	45
2000	1.5	75
2003	3	100
2007	5	126
2011	6	155
2012	7	164
2015	10?	?
2020	15?	?

present many workplace hazards, which are discussed in Chapter 2. The turbine equipment itself is massive and must be installed with barges equipped with large cranes or with a specialized installation vessel; in just the past 12 years, the capacity (in megawatts) of offshore wind turbines has more than tripled, while the rotor diameter more than doubled (from approximately 75 to 164 meters) (see Table 1-1 and Figure 1-1).

Manufacturers such as Alstom, REpower, and Siemens are testing 6-MW prototype offshore wind turbines; Vestas is ready to test a 7-MW offshore turbine; and reports indicate that GE Energy is developing an offshore turbine with a potential capacity of 15 MW (EWEA 2012).¹⁰ To illustrate the size of these wind turbines, the nacelle of the Vestas 7-MW turbine will rise more than 110 meters above sea level, and its three rotor blades, 80 meters each, will have a diameter of more than 164 meters, exceeding the diameter of four Airbus A380 passenger planes placed nose to nose.¹¹ A turbine blade of the Siemens SWT-6.0-154 measures 75 meters, nearly the width of an Airbus A380 (see Figure 1-2).¹²

¹⁰ See also <http://www.renewableenergyfocus.com/view/20429/ge-to-develop-15-mw-wind-turbine>.

¹¹ <http://www.vestas.com/en/media/news/news-2010/news-display.aspx?action=3&NewsID=2624>.

¹² http://www.siemens.com/press/pool/de/pressebilder/2012/photoneWS/072dpi/PN201204/PN201204-06d_072dpi.jpg.

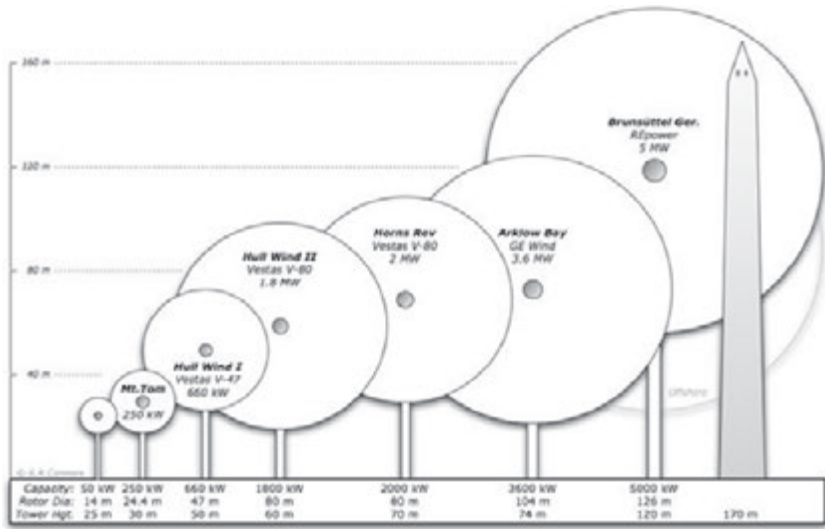

FIGURE 1-1 Growth in size and capacity of offshore wind turbines. (SOURCE: American Wind Energy Association presentation to committee by Michele Mihelic.)

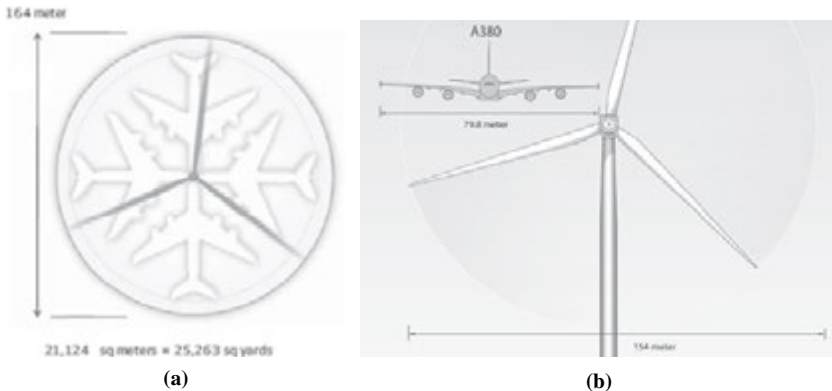

FIGURE 1-2 (a) Diameter of Vestas V164 7-MW turbine blades compared with four Airbus A380s; (b) blade length of Siemens SWT-6.0-154 6-MW turbine compared with Airbus A380.

Given the hazards of working with this massive equipment in a marine environment—in addition to the more typical hazards of working with high-voltage equipment, at heights, and generally in a marine environment—providing guidance that addressed the health and safety of offshore workers became of paramount importance to the responsible agency. In October 2011, DOI issued final regulations under 30 CFR 585, Renewable Energy and Alternate Uses of Existing Facilities on the Outer Continental Shelf, for renewable energy development activities on the OCS, giving the Bureau of Ocean Energy Management (BOEM) authority for the Renewable Energy Program (*Federal Register* 2011).¹³

According to the regulations, one of BOEM's responsibilities is to ensure that "renewable energy activities on the OCS and activities involving . . . marine-related purposes are conducted in a safe and environmentally sound manner." A lessee or operator is required to design projects and to "conduct all activities in a manner that ensures safety and will not cause undue harm." Among key reports operators are required to submit, along with supporting documentation as stipulated in 30 CFR 585, is a description of a safety management system (SMS) (see Box 1-1).

The regulations specify in detail what should be included in most of the reports [e.g., the construction and operations plan (COP) and the fabrication and installation report] and how the reports and documents will be reviewed and approved by BOEM.¹⁴ Thus far, however, this is not true for the SMS report.

BOEM reviews the description of the SMS submitted with the COP only for completeness of information.¹⁵ In addition, the regulations as written in §585.810 provide limited detail as to what an SMS should include and do not direct operators to specific standards or guidelines.

¹³ See also Reorganization of Title 30: Bureaus of Safety and Environmental Enforcement and Ocean Energy Management, on October 18, 2011. <https://federalregister.gov/a/2011-22675>.

¹⁴ For some reports, an approved third party, a "certified verification agent," independently assesses and certifies to BOEM that the facility is designed on the basis of sound practices and that components are installed according to acceptable practices.

¹⁵ If BOEM judges project activities "complex or significant" for an approved site assessment plan (SAP), COP, and general activities plan (GAP), the lessee must submit a description of the SMS as required by §585.810. BOEM reviews submitted documents for all necessary information by performing what it calls a "completeness review" (see BOEMRE 2011).

BOX 1-1

30 CFR 585, Subpart H—Environmental and Safety Management, Inspections, and Facility Assessments for Activities Conducted Under SAPs, COPs and GAPs

§585.800 How must I conduct my activities to comply with safety and environmental requirements?

- (a) You must conduct all activities on your lease or grant under this part in a manner that conforms with your responsibilities in §585.105(a), and using:
 - (1) Trained personnel; and
 - (2) Technologies, precautions, and techniques that will not cause undue harm or damage to natural resources, including their physical, atmospheric, and biological components.
- (b) You must certify compliance with those terms and conditions identified in your approved SAP, COP, or GAP, as required under §585.615(c), 585.633(b), or 585.653(c).

§585.810 What must I include in my Safety Management System?

You must submit a description of the Safety Management System you will use with your COP (provided under §585.627(d)) and, when required by this part, your SAP (as provided in §585.614(b)) or GAP (as provided in §585.651).

You must describe:

- (a) How you will ensure the safety of personnel or anyone on or near your facilities;
- (b) Remote monitoring, control, and shut down capabilities;
- (c) Emergency response procedures;
- (d) Fire suppression equipment, if needed;

BOX 1-1 (*continued*)

30 CFR 585, Subpart H—Environmental and Safety Management, Inspections, and Facility Assessments for Activities Conducted Under SAPs, COPs and GAPs

- (e) How and when you will test your Safety Management System; and
- (f) How you will ensure personnel who operate your facilities are properly trained.

§585.811 When must I follow my Safety Management System?

Your Safety Management System must be fully functional when you begin activities described in your approved COP, SAP, or GAP. You must conduct all activities described in your approved COP, SAP, or GAP in accordance with the Safety Management System you described, as required by §585.810.

The U.S. federal government has regulated the offshore oil and gas industry for decades but has no experience with offshore wind facilities. Europe has less than a 20-year history of regulating offshore wind, and U.S. regulations for offshore wind, including those for worker health and safety, are just now emerging (Musial and Ram 2010). As discussed in Chapter 3, the coverage of existing U.S. health and safety regulations and issues of jurisdictional boundaries within the United States are complex. The Occupational Safety and Health Administration (OSHA) normally has jurisdiction for all for worker health and safety regulations in the United States, including the OCS, unless another federal agency preempts OSHA by enforcing different regulations. BOEM’s intention to enforce health and safety regulations for wind energy through its SMS requirement has preempted OSHA, but only for activities on the OCS, generally beyond 3 nautical miles (see Figure 1-3). However, OSHA and approved state regulations will oversee activities in state waters within 3 nautical miles and on the Great Lakes.

BOEM officials believe that current regulations for the health and safety of offshore wind workers are “vague” but state that BOEM intends to “enhance them” on the basis of “best practices” from other

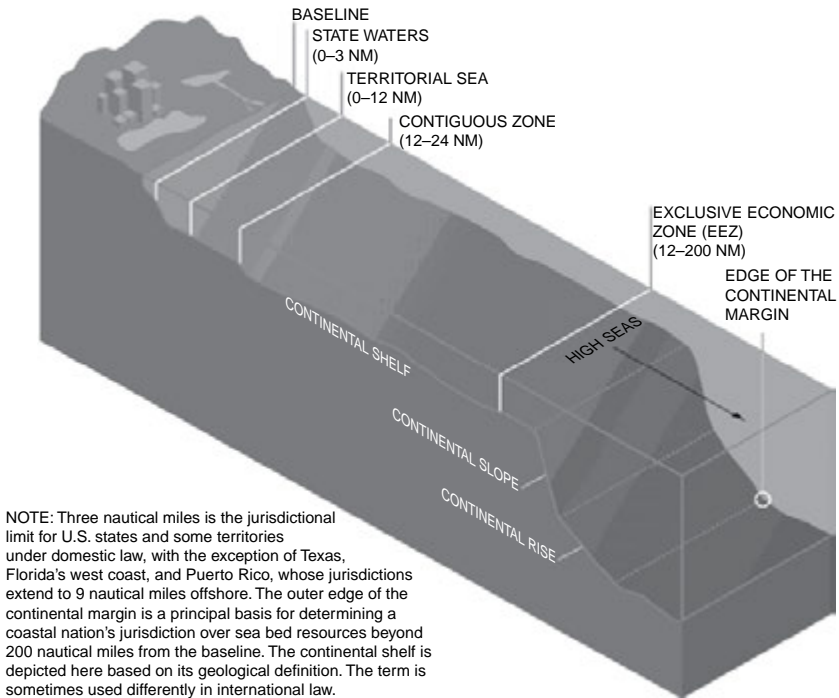

FIGURE 1-3 Jurisdictional boundaries in offshore waters. Illustration not to scale. (SOURCE: Primer on Ocean Jurisdictions: Drawing Lines in the Water, http://www.oceancommission.gov/documents/full_color_rpt/03a_primer.pdf.)

sources.¹⁶ Indeed, in many instances, other industries have rules, standards, and guidelines covering worker health and safety that are likely relevant to regulating offshore wind operations on the U.S. OCS. These regulations and standards are discussed further in Chapters 3, 4, and 5 but include some of the following:

- The Bureau of Safety and Environmental Enforcement (BSEE) conducts safety inspections of offshore oil and gas platforms for the U.S. Coast Guard (USCG) and has recently implemented safety and environmental management system (SEMS) requirements for the oil and gas industry.

¹⁶ “Regulating Worker Safety in Renewable Energy Operations on the OCS,” presentation to the committee by Robert LaBelle, BOEM, November 30, 2011.

- USCG oversees and regulates all inspected vessels and worker health and safety on oil and gas platforms, but the regulations that are promulgated for this setting may be unique to oil and gas operations.
- As mentioned earlier, OSHA or approved state regulations cover all workplace health and safety activities unless preempted by another federal agency. OSHA regulations are enforced for land-based wind farm operations and would be applied to wind farms in state waters. BOEM could adapt or adopt these regulations for offshore wind farms on the OCS, but they may be inadequate for BOEM's needs or for the unique marine environment.
- Organizations and associations, both domestic and international, have developed standards and guidelines for worker health and safety on offshore wind farms. They are in use by other countries and companies, but BOEM would need to adapt them to serve as regulations in the United States.

STUDY OBJECTIVE AND CHARGE

In an effort to meet its mandate for enhancing safety regulations, the former Bureau of Ocean Energy Management, Regulation, and Enforcement (BOEMRE) received the results of a study from the Marine Board of the National Research Council in April 2011 that focused on the structural safety of offshore wind turbines (TRB 2011). In August 2011, BOEMRE approached the Marine Board again to request an assessment of BOEMRE's approach for regulating the health and safety of wind farm workers on the OCS. The charge of the committee is shown in Box 1-2.

As discussed with the sponsor at the first meeting, the study's objective includes the examination of rules for worker health and safety on the OCS during each phase of wind farm development, from construction to decommissioning. In addition, the committee believed that it should consider the role of design and human factors engineering (HFE) in mitigating hazards, and this matter was accepted as part of the committee's charge after its first meeting. The committee recognizes that aspects of offshore wind farm operations occurring in state waters and the Great Lakes, although relevant to those on the OCS, are outside the scope of its charge and not within the enforcement jurisdiction of DOI. However,

BOX 1-2

Statement of Task: Committee on Worker Safety on Offshore Wind Farms

This study will assess the role of, and appropriate responsibilities for, regulating worker health and safety for wind farms on the Outer Continental Shelf (OCS). The study will examine the construction, operations and maintenance, and decommissioning of wind farms, and will consider the role of wind turbine design in mitigating workplace hazards. Starting with how oil and gas worker health and safety is regulated by the Bureau of Safety and Environmental Enforcement (BSEE) and the Bureau of Ocean Energy Management (BOEM),¹ as well as by other authorities having jurisdiction, the study will focus on the gaps or overlapping areas in the current regulations for worker health and safety for wind farms on the OCS. It will examine the impact on BOEM and BSEE's worker health and safety program in the absence of U.S. Coast Guard involvement and any potential implications of working with the Federal Energy Regulatory Commission and various electrical grid operators. The study will also examine the potential role of the Occupational Safety and Health Administration in regulating worker health and safety for wind farms on the OCS.

The study will identify workplace risks involved with wind farms, such as working in proximity to high-power electrical devices on offshore substations, extensive use of elevators for wind turbines in a highly corrosive environment, accessing turbine blades for repair via helicopter, crane operations during construction, and use of CO₂ fire suppression systems in potentially manned areas. The study will identify gaps in current regulations and recommend additional areas of workplace health and safety regulation deemed necessary.

BOX 1-2 (continued)

Statement of Task: Committee on Worker Safety on Offshore Wind Farms

Specific tasks for the study include:

1. Identification of unique risks to the health and safety of workers on wind farms, as compared to oil and gas operations on the OCS.
2. Identification of any gaps or overlaps in jurisdictional authority.
3. Evaluation of the adequacy of existing BOEM and BSEE worker health and safety regulations and recommendations on how to enhance regulations for worker health and safety on wind farms on the OCS.

¹On October 1, 2011, the Department of the Interior reorganized the Bureau of Ocean Energy Management, Regulation, and Enforcement and established two new, independent bureaus—BSEE and BOEM. <http://www.doi.gov/news/pressreleases/Interior-Department-Completes-Reorganization-of-the-Former-MMS.cfm>.

the committee believes that stakeholders on both sides of jurisdictional lines can benefit from developing a more consistent policy and coordinating efforts toward that goal.

The committee's charge is concerned with issues of occupational health and safety during the development of wind farms but does not include issues pertaining to the siting, leasing, or permitting process. The study does not examine environmental hazards such as effects on wildlife and the seabed, since they fall under the National Environmental Policy Act. Furthermore, the study does not discuss the economics of wind farms, including such topics as financing and overall costs of commissioning and operating, nor does it discuss any particular tax incentives.

The committee considers the role of design and HFE in protecting worker health and safety, but hazards resulting from structural failure are not part of its charge. They were addressed in a previous study (see TRB 2011).

Although construction on proposed offshore wind projects has not started, the committee recognizes DOI's urgent need to develop more explicit rules governing worker health and safety. In approaching its task, the committee recognizes BSEE's SEMS (goal-based) approach to safety, which is implicit in its requirement for SMSs, and the value of aligning its regulatory oversight of worker health and safety within this framework. In Chapter 5, the committee evaluates the SMS framework required by 30 CFR 585.810 and reviews the relevant elements of other SMSs (for example, see API 2004, ANSI and AIHA 2012, and BSI 2007).

To meet DOI's objective of developing renewable energy on the OCS in a "safe and environmentally sound manner," the committee believes that any enhanced framework requires a careful balance: it needs enough detail to ensure consistency and equity but also enough flexibility to avoid an overly prescriptive "one-size-fits-all" approach. This balance is most likely to be achieved through a process that brings many stakeholders to the table for thorough discussion and negotiation.

To fulfill its charge, the committee met five times over a 1-year period and was briefed by stakeholders. To address its first task, the committee reviewed the offshore wind farm environment and identified hazards unique to offshore wind farms. Next, the committee compared hazards of offshore wind farms with those of the offshore oil and gas industry. For its second task, the committee examined the jurisdictional authority of relevant federal agencies and the regulatory approaches offered by each and determined whether gaps or overlaps of jurisdiction exist. For its third task, the committee evaluated the current regulatory framework and provided options for enhancing regulations for worker health and safety on wind farms on the OCS.

Over its first four meetings, the committee received briefings from representatives of federal agencies about jurisdictional responsibility and existing regulations for worker safety on the OCS. The committee also heard what other stakeholders, including industry associations, wind turbine manufacturers, marine construction companies, and classification societies, are doing to promote offshore worker health and safety and how HFE is used in the design and operation of oil and gas facilities in the Gulf of Mexico.

ORGANIZATION OF THIS REPORT

Chapter 2 briefly discusses wind turbines and wind farm development (both onshore and offshore). Hazards involved with each phase of the process are introduced, and hazards that are unique to offshore operations are identified. Hazards and risks associated with offshore oil and gas operations and relevant to offshore wind development are also discussed. Chapter 3 reviews regulations for worker health and safety and federal jurisdiction on the OCS and then discusses how the relevant agencies interact. That chapter also examines standards and guidance from relevant domestic and international sources. Chapter 4 further describes the hazards of offshore wind farms introduced in Chapter 2 and maps them to relevant regulations, standards, and best practices. Chapter 5 evaluates the regulatory framework and discusses options for addressing potential gaps. Chapter 6 states the committee's conclusions, key findings, and recommendations for enhancing regulations for worker health and safety on wind farms located on the OCS.

REFERENCES

Abbreviations

AIHA	American Industrial Hygiene Association
ANSI	American National Standards Institute
API	American Petroleum Institute
BOEMRE	Bureau of Ocean Energy Management, Regulation, and Enforcement
BSI	British Standards Institute
EWEA	European Wind Energy Association
GWEC	Global Wind Energy Council
NREL	National Renewable Energy Laboratory
TRB	Transportation Research Board

ANSI and AIHA. 2012. *Occupational Health and Safety Management Systems*. ANSI/AIHA/ASSE Z10-2012. Falls Church, Va.

API. 2004. *Recommended Practice for Development of a Safety and Environment Management Program for Offshore Operations and Facilities*, 3rd ed. API RP 75. Washington, D.C.

BOEMRE. 2011. *Process Guide: Offshore Renewable Energy Installations, and Annexes 1–4, Version 1.0*. July 27.

BSI. 2007. *Occupational Health and Safety Management*. BS OHSAS 18001. London.

- EWEA. 2012. The European Offshore Wind Industry Key 2011 Trends and Statistics. Jan. 2012. http://www.ewea.org/fileadmin/files/library/publications/statistics/EWEA_stats_offshore_2011_02.pdf. Accessed Feb. 7, 2013.
- EWEA. 2013. The European Offshore Wind Industry: Key Trends and Statistics 2012. Jan. 2013. http://www.ewea.org/fileadmin/files/library/publications/statistics/European_offshore_statistics_2012. Accessed Feb. 7, 2013.
- Federal Register*. 2009. Renewable Energy and Alternate Uses of Existing Facilities on the Outer Continental Shelf; Final Rule. Vol. 74, No. 81, April 29, pp. 19638–19871.
- Federal Register*. 2011. Reorganization of Title 30: Bureaus of Safety and Environmental Enforcement and Ocean Energy Management. Vol. 76, No. 201, Oct. 18, pp. 64432–64780.
- GWEC. 2013. Global Wind Statistics 2012. Feb. 11. http://www.gwec.net/wp-content/uploads/2013/02/GWEC-PRstats-2012_english.pdf. Accessed Feb. 11, 2013.
- Musial, W., and B. Ram. 2010. *Large-Scale Offshore Wind Power in the United States: Assessment of Opportunities and Barriers*. Report TP-500-40745. National Renewable Energy Laboratory, Golden, Colo.
- NREL. 2012. Strengthening America's Energy Security with Offshore Wind. April. <http://www.nrel.gov/docs/fy12osti/49222.pdf>. Accessed March 1, 2013.
- TRB. 2011. *Special Report 305: Structural Integrity of Offshore Wind Turbines: Oversight of Design, Fabrication, and Installation*. Transportation Research Board of the National Academies, Washington, D.C. <http://www.trb.org/Publications/Blurbs/165263.aspx>.

Hazards of Wind Farms

As a way of providing context to the study, Chapter 2 gives a brief overview of wind turbines and wind farms and presents a short outline of the wind farm development process. It compares tasks common to land-based and offshore development and indicates those that are unique to offshore. The chapter also examines general similarities and differences between offshore oil and gas and offshore wind energy hazards. In addressing Task 1 (see Box 1-2) of the committee's charge, this chapter briefly describes the hazards involved with the phases of wind farm development and provides background for the more in-depth discussion of offshore hazards in Chapter 4. In addition, Chapter 2 provides an introductory comparison of the relative risk of hazards associated with offshore oil and gas operations that are relevant to offshore wind farms and that will be discussed further in Chapter 4.

WIND ENERGY TURBINES

Whether located onshore or offshore, wind turbines¹ are characterized as machines or devices that convert wind energy into electricity. They consist of similar components, including a tower that rests on a substructure (or foundation), a nacelle that sits on top of the tower, and a rotor assembly that connects to the nacelle and includes a hub to which

¹ Wind turbines consist of two basic designs, horizontal axis and vertical axis. Horizontal axis (or propeller-style) wind turbines, the more common of the two, are configured with rotor blades perpendicular to the wind direction and with the main axis of rotation in the horizontal plane. Vertical axis turbines have a vertical main axis of rotation (see <http://www.awea.org/learnabout/faq/windturbine.cfm>, accessed March 1, 2013). This study will focus on horizontal axis turbines, which represent nearly all larger, "utility-scale" turbines.

the blades are attached (see Figure 2-1). For offshore wind turbines and land-based wind turbines, once the technician is inside the wind turbine, most tasks are exactly the same. Thus, for a majority of the tasks inside a wind turbine, the hazards and risks are similar.

The tower usually consists of two to four tubular steel sections that are joined together and coated with a variety of sealants and paints. Resting

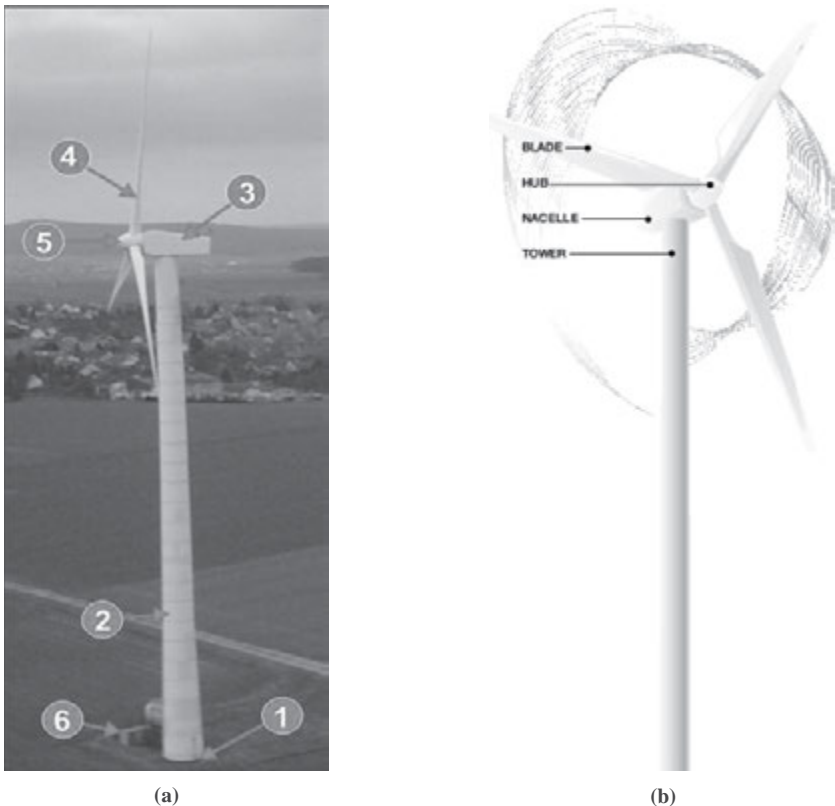

FIGURE 2-1 Common components of a land-based wind turbine: (a) photo indicating ① foundation, ② tower, ③ nacelle, ④ rotor blade, ⑤ hub, and ⑥ transformer; (b) diagram indicating blade, hub, nacelle, and tower. (SOURCE: Figure 2-1a, World Wind Energy Association, <http://www.wwindea.org/technology/ch01/estructura-en.htm>; Figure 2-1b, American Wind Energy Association, http://www.awea.org/issues/supply_chain/upload/Supplier-Handbook.pdf.)

on a foundation, towers vary in height, depending on site and available wind speeds, and will narrow slightly from the base to the opening in the top. Although towers are still equipped with ladders, most modern towers are also equipped with lifts. The foundation is a structural support system that stabilizes the wind turbine by transferring the vertical and horizontal forces acting on it to the surrounding ground. For land-based turbines, foundations are generally some type of reinforced concrete slab, monopile, or multipile solution and are determined by the geotechnical conditions of the site (AWEA n.d.).

Substructures for offshore turbines are also designed according to site conditions, including water depth, currents, wave height, wind speed, and seabed conditions. The European wind industry has relied on monopile and gravity-based substructures for water shallower than 25 meters. For water deeper than 25 meters, the industry is researching the use of other types of substructures, including jacket, tripod, triple, suction bucket, and floating.² The focus of this study is on the monopile substructure.

The nacelle is the boxlike compartment resting on top of the tower and containing most of the equipment required to convert wind energy into electricity. This equipment (see Figure 2-2) includes the drivetrain components—rotor shaft, gearbox (unless the design incorporates a direct drive turbine, which does not have a gearbox), and generator. Also included are remote sensors and systems for monitoring and controlling the turbine, such as an anemometer, brake system, cooling system, and yaw drive, which keeps the rotor hub facing the wind (AWEA 2009). The rotor assembly for a geared turbine connects to the nacelle and consists of the hub, covered by a nose cone, blades, and pitch drive (for a sense of overall turbine size, see Figure 2-3). The typical utility-scale turbine has three blades that range in length from 35 to 60 meters, but manufacturers are testing larger blades. Each blade is bolted onto the hub along with the pitch drive, which allows the blade to rotate on its axis, controls the amount of wind captured, and ensures that the turbine can be stopped either locally or remotely by pitching the blades completely out

² For a more detailed review of substructure and foundation types, see TRB 2011, AWS Truewind 2009, and Tveiten et al. 2011.

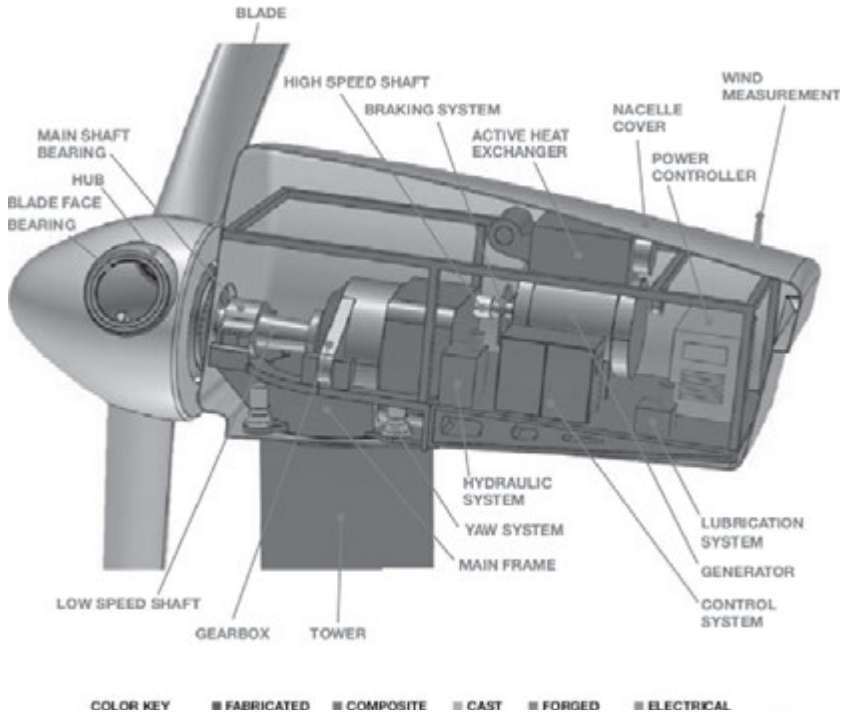

FIGURE 2-2 Nacelle components. (SOURCE: http://www.awea.org/issues/supply_chain/upload/Supplier-Handbook.pdf.)



FIGURE 2-3 Offshore 5-MW wind turbine with wind technicians on board. (SOURCE: <http://www.areva.com>.)

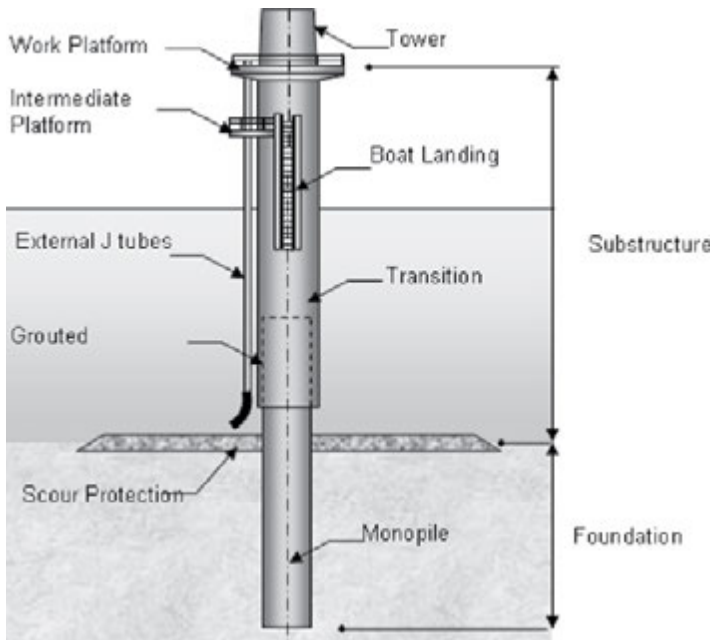

FIGURE 2-4 Transition piece and substructure for monopile foundation. (SOURCE: EWEA 2009.)

of the wind. The hub connects the rotor assembly to the driveshaft and is heavy and rigid to absorb excessive amounts of vibration (AWEA n.d.). Because an offshore turbine is exposed to a more demanding environment than is a land-based turbine, it requires several design modifications. They include a strengthened tower to handle the added force from waves, a pressurized and climate-controlled nacelle compartment to protect internal components from the corrosive marine environment, a place within the tower to provide emergency accommodation for workers, and an external access platform or transition piece (see Figure 2-4) to facilitate access and maintenance (TRB 2011).

WIND FARMS

As mentioned in Chapter 1, the National Renewable Energy Laboratory (NREL) estimates the potential for generating wind energy in the United States at more than 12 million megawatts (MW) (NREL 2011), with

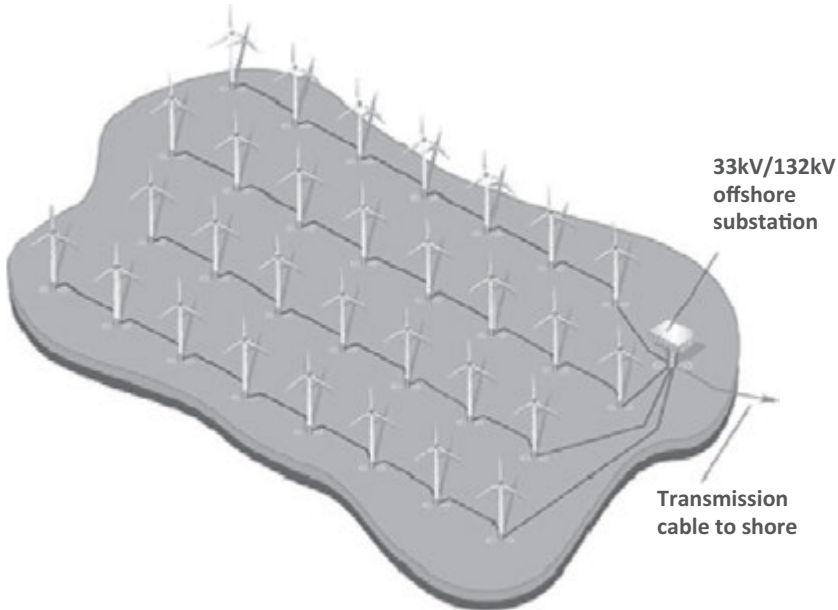

FIGURE 2-5 Sample layout of offshore wind farm (kV = kilovolt). (SOURCE: Barrow Offshore Wind Project: <http://www.bowind.co.uk/popup1.htm>.)

most of this potential coming from areas located offshore or in the central part of the country.³ As of the end of December 2012, all 60,007 MW of installed capacity in the United States was from land-based wind farms (AWEA 2013). Wind farms consist of one or more independently operating wind turbines that generate power, are connected together with electric cables, and are connected to an electrical substation. The electrical substation or, when offshore, an electric service platform (ESP) collects the power output from the wind farm and transmits it to the grid (see Figures 2-5 and 2-6).

Compared with land-based wind farms, offshore wind farms can be larger both in size and in the amount of power generated because the wind resources are more abundant. The size of turbines for land-based

³ For a detailed map of U.S. land-based and offshore wind resources, see http://www1.eere.energy.gov/wind/resource_assessment_characterization.html, accessed March 1, 2013.

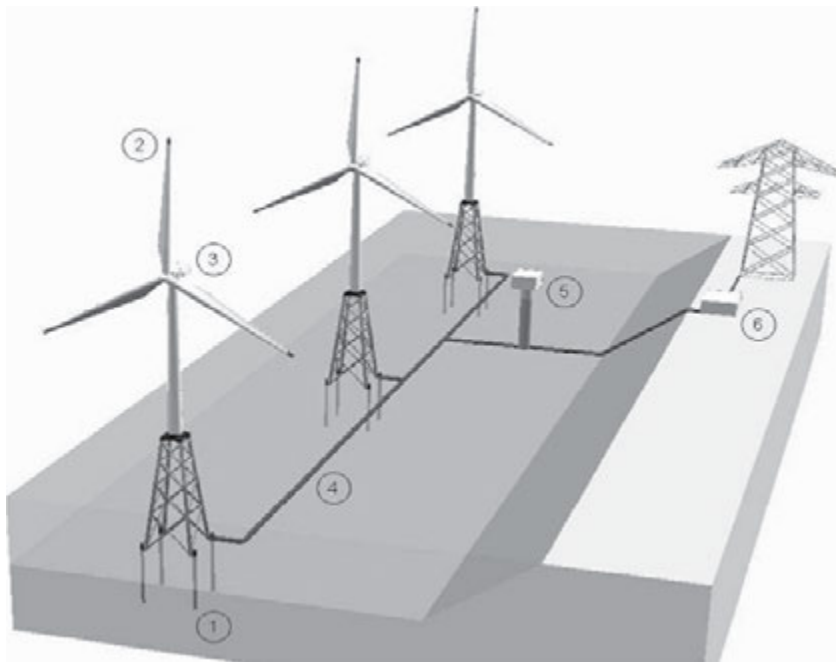

FIGURE 2-6 Simple layout of offshore wind farm: ① foundation, ② wind turbine generator, ③ nacelle, ④ interturbine cables, ⑤ offshore substation and export cable, and ⑥ onshore grid connection. (SOURCE: Presentation by Bill Wall at the Offshore Energy Knowledge Exchange Workshop, April 11, 2012, Washington, D.C. http://www.wind.energy.gov/pdfs/offshore_energy_knowledge_exchange_workshop_report.pdf.)

wind farms is subject to the constraints of vehicles and installation equipment. Trucks hauling components and installation equipment must travel over existing roads, often to remote areas, which limits access to areas and ultimately the size and capacity of land-based turbines. In contrast, marine transportation and installation equipment can accommodate larger and heavier turbine components for offshore wind farms. Electricity from land-based wind farms must be transmitted over greater distances. The strongest onshore wind resources are located in more rural and less populated states, away from the major coastal population centers where, despite high demand for electricity, land is less available and has more competing uses. However, offshore

wind resources are located closer to the densely populated urban centers and would allow shorter transmission distances (Musial and Ram 2010).

Developing a Wind Farm

Describing the process of developing and operating a wind farm in detail is beyond the scope of this study. However, the process is much longer for offshore than for onshore wind farms, involves multiple steps, and is logistically complex. Outlining these steps and planning the entire project thoroughly, from start to finish, are necessary for any successful wind project.

Developers of land-based wind farms must consider many issues.⁴ The preinstallation phase involves identifying a potential wind farm site and understanding the suitability of its wind resources—important factors for any developer. NREL provides some information on existing wind resources for the United States.⁵ More detailed wind resource data are collected through meteorological towers installed at or near the potential site, a process that can take up to 3 years but that can provide data useful in optimizing turbine location. Wind farm developers must also understand the transmission system and how far the power that will be generated must travel to reach the grid. Building an extended transmission infrastructure to join a wind facility's substation to the grid can add complexity to the project. Electrical cables connecting each turbine will also need to be installed, and developers will need to consult topographical information in preparing the land at a site. This information will help in placing turbines, since each tower foundation will need to be prepared and leveled, and in designing access roads to the site. How the installation equipment, wind energy components, and work crews get to the project site to construct and service the wind farm must also be considered. Building new roads to each turbine and updating or expanding the transportation infrastructure will add to a project's cost and complexity.

⁴ More information concerning the development and siting of land-based wind energy projects in the United States is given by http://www.awea.org/sitinghandbook/downloads/AWEA_Siting_Handbook_Feb2008.pdf.

⁵ See also <http://www.windpoweringamerica.gov/>.

Developers of offshore wind projects face similar issues, including extensive planning and a costly process that can take years. Once acceptable sites are identified⁶ and developers obtain the appropriate leases and permits for state or federal waters, their work has just started. All the decisions that the developer makes before installation have consequences and affect all future outcomes. This is especially true of design decisions and health and safety considerations, both of which are discussed in more detail in Chapter 5. Consideration of health and safety should begin during the initial planning stages and continue throughout the life of the project. Decisions must therefore be made with as much detailed information as possible, including data from site assessment activities and guidance from experienced individuals. Like their land-based counterparts, offshore wind farm developers must understand available wind resources and collect data from meteorological towers. Developers must survey the potential site, collect metocean (wind, wave, and current) data, and understand meteorological conditions such as wind levels and wave conditions. Developers must also understand the seabed conditions at the site, including currents and the subsea terrain, both of which are important in predicting and protecting against scour—erosion of the seabed adjacent to the support structure. Next, the developer will need to choose the type and size of the turbines to be installed at the wind farm. All these decisions will influence the detailed design and planning of the wind farm—for example, the type of foundation to be used, how the installation will occur, the number of qualified personnel needed, the need for and availability of various types of equipment (including vessels), how cabling between turbines will be done and the electrical power exported to shore, what port facilities will be needed, the overall operations and maintenance strategy, and the decommissioning plan. The developer is constantly aware that work on the wind farm occurs in a marine environment and that all access to the site is by boat or by helicopter; workers cannot just drive up to the work site and get out of their truck, nor can they easily evacuate a wind turbine in an emergency.

⁶ See also <http://www.nrel.gov/gis/wind.html>.

Phases of Offshore Wind Farm Development

The major phases of wind farm development include installation of the components of the wind turbine, installation of cables connecting the turbine together and to the electrical grid, the commissioning of the turbine into service, the operations and routine maintenance stage, and the eventual decommissioning of the wind farm. At the start of installation, the layout site and staging port cover a large area and are important for the overall success of the project. The port must be able to accommodate the large freight vessels that deliver the foundations, transition pieces, and turbine components and must allow for component offloading, storage, and preassembly as well as loading onto repurposed installation vessels as needed. The layout site also must be able to handle the weight of all the delivered equipment; otherwise, the quay could buckle under the total load.

Installation

This phase involves the installation of major components, among them the foundation and transition piece, and the assembly of the wind turbine. It includes most of the heavy lifting of turbine components. Although the number of workers involved in the installation phase will depend on the size of the wind farm, this is the most personnel-intensive phase in its development and operation.

Foundation or Substructure and Transition Pieces Once the appropriate foundation and substructure components are fabricated, installation can begin. If a monopile is being installed, for example, a specialized jack-up vessel equipped with a crane and pile-driving ram could be used. Monopiles are loaded onto one or more vessels and transported to the installation site. The monopile would be lifted into place and driven into the seabed to a depth of 20 to 30 meters, depending on seabed conditions and design requirements. After foundations or substructures are installed, the transition piece is placed on top of the monopile at a specific height and grouted into place (Thomsen 2012). Transition pieces (see Figure 2-4) are of standard sizes and include an external work platform, a boat landing, ladders, a diesel generator to provide power for lighting and for other purposes when the turbine is not running, a crane for lifting

components, decks, J-tube supports, and other cable connections. Work platforms are used during all phases of operations and provide access to the wind turbine (Melnik and Andersen 2009). To prevent erosion, rock armoring or another type of scour control may be added around the turbine foundation after installation (McNeilan and Smith 2011). Installation of the foundations or substructures for a wind farm will be complete or well under way before that of the wind turbines themselves begins.

Once these structures are in place, the components needed for assembling a specific number of wind turbines are loaded onto vessels or transport barges at the staging area and are moved to the installation site. An installation vessel or crane barge accompanies transport barges to the site, where the jack-up vessel deploys next to the foundation and begins the installation of the turbine components.

Wind Turbine Components A common assembly technique is to lift the base tower from the transport vessel; place it on the transition piece; bolt it down; and then lift, place, and bolt the next tower section on the previous tower section. Once the two to four tower sections are in place, the nacelle is lifted and secured to the top of the tower. The hub is lifted and bolted onto the nacelle if it is not already secured there, and then individual turbine blades are bolted onto the hub. In some instances, the hub with all three turbine blades is lifted and attached to the nacelle. This is referred to as a rotor lift. The process is repeated until all wind turbines of the wind farm are assembled.

Cable Installation and Electrical Substation

Each wind turbine in a wind farm generates power independently and sends its power to a transformer located at the base of the tower. Submarine cable interconnects each turbine with up to a dozen other turbines to create an array. Specialized cable installation vessels and underwater cable installation equipment connect the turbines and embed the electrical cable up to 2 meters below the seabed.⁷ Each array is then connected to the central substation or an ESP. The power

⁷ Presentation at the Offshore Energy Knowledge Exchange Workshop, Washington, D.C., April 11, 2012, by J. Whitman. http://www.wind.energy.gov/pdfs/offshore_energy_knowledge_exchange_workshop_report.pdf.

generated from each turbine is sent to the transformer, where it is increased and sent to the ESP.

The voltage generated in an individual turbine is classified as low voltage, usually below 1,000 volts, although some larger turbines can generate voltages of up to 3,000 volts. Turbines are interconnected and use individual transformers to step up power to medium voltage, from 10 to 36 kilovolts, and to send to the ESP. ESPs typically step up voltage from under 36 kilovolts to 100 to 220 kilovolts and send the electricity to shore (EWEA 2009).

The ESP is a multistory offshore substation and is the central point for all interconnected wind turbines. All power generated from the turbines is transmitted via the underwater cable system to the ESP, where additional transformers increase the voltage level again to minimize electrical losses and then send the electricity to a land-based substation and ultimately to the grid through another undersea cable that can handle the higher voltage. Structurally, ESPs are similar to a typical offshore oil and gas platform. Generally, they are braced-frame structural systems that extend from the seabed to roughly 20 feet above the waterline, with three or more support legs and driven pile foundations. An above-water frame and deck system is then connected to the jacket structure serving as a platform for the electrical equipment.

Installation of an ESP involves transporting the jacket structure and support piles to the site on a barge. The jacket is set on the seabed, and the support piles are driven to hold it in place. The deck structure is then transported to the site via a barge and is lifted into place atop the jacket, where it is welded to the jacket legs. Typically, the deck is transported to the site fully outfitted with the equipment necessary for the ESP operations. In larger wind farms and those farther offshore, the ESP is sometimes a manned structure providing living quarters for turbine technicians, medical personnel, and personnel watching the wind farm's remote monitoring systems. It is also provided with advanced rescue equipment and has a helicopter landing platform.

Specialized cable installation vessels and underwater cable installation equipment are also used to bury cable from the ESP to the onshore connection point. Once the installation process is complete and before normal operations of the wind farm can begin, the turbine must be commissioned. For financial reasons, on larger wind farms the turbines are

handed over individually or in smaller groups to start producing electricity as soon as possible.

Commissioning of a Wind Turbine

Once a wind turbine is assembled, teams of workers begin the steps necessary for making it operational. This is referred to as the commissioning phase and includes the inspection and testing of turbine functionality and electrical infrastructure, including substation. This phase can be work-intensive and may require a team of three to six people and more than 1,000 person-hours for each wind turbine.⁸ During commissioning, the work team performs quality control activities and tests the internal systems, including the turbine control systems, the remote monitoring and access systems, and all electrical systems. The rotor blades are set in slow rotation to test the drivetrain, along with the overspeed protection system. Once the turbine is connected to the grid, it is further tested in sequences and finally put into operation. This phase is of particular interest because the risk of electrical incidents is now present.⁹

Operations and Maintenance

Once they are operational, wind farms are essentially unmanned offshore facilities with personnel accessing them only to perform maintenance and repairs. Scheduled maintenance ensures ongoing functionality of the equipment and system, and scheduled inspections evaluate condition; maintain safety systems; and satisfy lease, permit, and regulatory requirements. Such routine access is often accomplished with smaller vessels that do not have cranes or large carrying capacity. Unscheduled maintenance, which can include major repairs such as replacing a major wind turbine component, may require the use of larger jack-up installation vessels that can carry replacement components and more personnel (Thomsen 2012). If the manufacturer supplies a warranty period for the wind turbines, the work crews supplied during the operations and maintenance period will consist of a team of two or more people for every 20 to 30 turbines. Routine or scheduled maintenance requires

⁸ J. Nielsen, Siemens, presentation to the committee, April 2012.

⁹ J. Nielsen, Siemens, presentation to the committee, April 2012.

approximately 40 hours per year; unscheduled maintenance requires a similar or a smaller amount of time.¹⁰

Several presentations to the committee indicated that manufacturers are integrating automated systems with their wind turbines more often, so that the need for traveling to offshore facilities has decreased.¹¹ These systems allow for the remote monitoring of operational status and controlling of individual turbine performance characteristics such as rotor speed, blade pitch, and yaw. Other centralized software systems are often used to gather, transmit, and analyze indicators and the operational status of an entire wind farm. These systems, referred to as supervisory control and data acquisition (SCADA) systems, can collect data on meteorological conditions and power output from individual turbines or the entire wind farm. The data from a SCADA system are useful in remote supervisory and control actions, such as monitoring for safe operation and operating at an optimal state, diagnosing and repairing turbines, and starting and stopping turbines as needed for routine maintenance and in emergency situations (Lynn 2011, 151–152). Although the need for on-site visits will not be eliminated, wind farm operators can use remote monitoring and control systems to decrease the number of on-site visits and ultimately to reduce the exposure of their workers to hazards.

Decommissioning

Current regulations require wind farm operators to decommission or remove all facilities and wind farm components at some point in the future.¹² The committee is unaware of any offshore wind projects that have been decommissioned anywhere in the world, but the process is understood to be the reverse of the installation process and could be more hazardous and difficult than the installation phase. This process would include the removal of all underwater cables, wind turbines, towers, ESP, transition pieces, and foundations and would require equipment and vessels similar to those used during installation.

¹⁰ J. Nielsen, Siemens, presentation to the committee, April 2012.

¹¹ J. Nielsen, Siemens, presentation to the committee, April 2012.

¹² See 76 FR 64776, Subpart I—Decommissioning. <https://federalregister.gov/a/2011-22675>.

Wind Farm Development Tasks Common to Land-Based and Offshore Facilities

As mentioned earlier, the development of land-based and offshore wind facilities requires extensive planning and thorough knowledge of site conditions. The two types of operations need a staging area for storing large components before installation. Cranes are used in both land-based and offshore projects. During land-based operations, cranes in the staging area or warehouse area will load components onto trucks or trains for transport to the installation site. For offshore projects, cranes load the components onto transport vessels before floating them to a project site. Large cranes are also used for lifting the individual components during assembly for both land-based and offshore wind facilities. The installation of electric cables between turbines and to a substation and then to the grid is interconnected in a similar pattern in land-based and offshore wind farms, but the introduction of water in the offshore environment adds another dimension, since cable installation is accomplished with remotely controlled vehicles. Likewise, the manual handling of components, for example bolts and cables, in a wind turbine is similar for land-based and offshore facilities, as are most of the tools and equipment. Once inside the turbine, the difference is not noticeable.

Wind Farm Development Tasks Unique to Offshore Facilities

The marine environment differentiates offshore work from that done onshore. Work is done on the water, in or with a boat; under the water in diving operations; or above the water, in or on a wind turbine. Weather is a factor for land-based work, but in the offshore environment, the weather and sea state (wind speed, wave height, visibility, etc.) are deciding factors. A typical offshore wind project will plan for significant downtime due to bad weather conditions. Unlike workers onshore, offshore technicians do not drive themselves to the work site but are transported by a vessel, which has its own crew. Offshore technicians are dependent on a complex logistical arrangement that includes transfer to and from a vessel or helicopter, coordination with other marine vessels, and extra marine rescue equipment (for example, an immersion suit). Training,

if applicable, may be required, such as in Standards of Training, Certification, and Watchkeeping or Helicopter Underwater Egress Training.

In an offshore environment, the transfer to the wind turbine is not a matter of a few steps on a normal staircase but an operation that may require the use of fall protection equipment, coordination between the technician and the vessel crew, and additional climbing of ladders of 5 to 20 meters while exposed to the given weather conditions. On land, technicians rely on a well-stocked truck parked near the wind turbine that they can use to drive away. Offshore technicians rely on the transfer vessel for transportation and emergency evacuation, for spare components or missing tools, and for breaks. Logistical coordination with the transport vessel is critical for successful offshore work. Offshore communication and logistics are also critical as more work teams are shuttled by transfer vessels and work simultaneously in more wind turbines. Typically, a wind project will have to provide its own communication network. Often, very high frequency radios are used, but in some cases signals cannot cover the span of the wind farm, and repeaters are needed. In some cases the vessels are also used to relay the communication signals.

Advanced weather monitoring is crucial for offshore work, especially in severe weather situations and when lightning is a threat. In cases of sudden severe weather when transfer vessels are unable to collect all offshore work teams, technicians remaining in a wind turbine are supplied with enough provisions for up to 3 days but must stay in designated areas and observe special rules and procedures. Although diving operations are kept to a minimum, they are sometimes required for offshore work, for example to position a foundation, prepare for cable laying, or inspect the turbine.

Offshore wind workers live onshore and are transported back and forth on a daily basis, although accommodations aboard an ESP or similar offshore platform could be utilized. However, if the wind farm is far offshore, a hotel vessel (or floatel) is sometimes provided to minimize travel time. Living conditions on offshore platforms and floatels are normally good, but technicians without offshore work experience will need time to acclimate to the new living environment related to life at sea.

Similarities and Differences Between Offshore Oil and Gas Facilities and Offshore Wind Farms

The oil and gas industry has operated offshore for decades and has developed many best practices and standards that can be used as a foundation for offshore wind development. Oil and gas developers started with practices and equipment for land-based applications and adapted them to the marine environment, as offshore wind developers have started to do. The oil and gas industry's understanding of seabed geology and meteorological conditions and their effects on design and operations is proving beneficial to the offshore wind industry. The wind industry is using innovations such as jack-up vessels and different foundation types, which were first developed by the oil and gas industry (Melnyk and Andersen 2009).

One difference between an oil and gas industry facility and a wind farm is the way the workers get to work. Oil and gas employees travel to and from offshore structures by crew boat. The workers transfer from a boat to a small landing platform on the structure by using a rope attached to the structure to swing to and from the boat, or they transfer between boat and platform by using a Billy Pugh basket and the platform's crane. As offshore platforms became larger and moved farther from shore, the transfer of workers by helicopter became more routine. On some European offshore wind farms workers are lowered from a helicopter to a platform on the nacelle, but for the most part offshore wind farm workers will continue to rely on transfers from a boat to the ladder and the transition piece on the wind turbine. Although technical solutions providing a more stable transfer walkway between the vessel and the wind turbine are available, moving people from a vessel to a wind tower presents more potential for individual injuries than landing them by helicopter on an offshore oil and gas structure.

A second difference between an offshore oil and gas platform and an offshore wind turbine is the inherent unknown of the geological structure underneath an oil and gas platform, such as an undetected high-pressure gas pocket or unexpected subsidence of the earth's surface, neither of which is a likely source of an emergency on an offshore wind turbine.

A third difference is that during the exploration phase many oil and gas platforms are often manned by personnel who not only travel back

and forth between shore and platform by helicopter or boat but also live on the platform and service and operate the facilities for an extended period of time, usually ranging from 7 to 30 days straight on a 12-hour-per-day work schedule. Depending on the size of the facility and the ongoing operations, up to 250 people may be on board at any given time, which may result in much activity in a small area. An error by one employee, therefore, can have a far-reaching impact on the entire platform. An offshore wind farm will have fewer workers on or near the wind turbine at any one time, so the consequences of an error by an employee are less than those on an oil and gas facility.

A fourth difference is the nature of the product with which oil and gas personnel are working—hydrocarbons under pressure—which makes an offshore oil and gas platform a more likely and varied source of hazards than an offshore wind turbine. In addition, the various types of dangerous equipment used to work with the hazardous product on an offshore oil and gas platform do not exist on a wind turbine. Such equipment can include “pigs,” gas compressors, and pipeline pumps, which work at high pressure. A “pig” is a maintenance tool that is forced through the oil and gas pipeline by using a “pig launcher” either for clearing the pipeline or for inspecting it. A gas compressor is a mechanical device that is capable of compressing gas by reducing the volume of the container enclosing the gas. This is done by placing the gas in a container with a mechanical wall that is able to push forward. The process puts the gas under extreme pressure and allows it to be transported through pipes. Crane accidents are also frequent causes of injuries and fatalities on an oil and gas platform. Although cranes are used on wind turbines, they are used less frequently and involve fewer personnel.

Hazards Involved in Wind Farm Development

Hazards to worker health and safety related to wind farm development can occur during the major phases of the project: installation, commissioning, operations and maintenance, and decommissioning. Many common hazards of these phases are summarized in Box 2-1.

- Weather conditions such as high winds, extreme cold and heat, and icy or wet surfaces can expose workers to environmental and slip hazards.

BOX 2-1

Common Hazards for Offshore Wind Farms

The following list of hazards is not comprehensive and is not a substitute for a formal hazard analysis that is part of the safety management system development process.

Assembly and fit-up (installation only)

Chemical exposure

Confined space entry

Crane and lifting

Demolition (decommissioning only)

Diving

Dropped objects

Electrocution and arc flash

Emergency evacuation

Electric and magnetic field exposure (operations only, once power is being generated)

Falls from height

Fire

Human factors health issues (climbing, awkward postures)

Human factors safety issues (pinch points, rotating equipment)

Noise exposure

Personnel transfers (falls into the water); access by boat; access by helicopter

Slips and trips

Vibration

Weather exposure

SOURCE: Generated by the committee.

- Loading materials during transport can lead to dropped objects and uncontrolled lifts.
- During development, crane operations occur in windy areas and introduce lifting and crush hazards while large components or heavy pieces of equipment are moved.
- Personnel working in the tower or the nacelle are at heights and climb ladders multiple times per day, and they face fall hazards or exposure to dropped objects.
- In a wind turbine, workers encounter confined spaces and are exposed to fumes, dust, and toxic chemicals and materials.
- Electrical hazards, such as electrical burns and electrocution, are a concern.
- Workers confront awkward postures, prolonged kneeling, and repetitive upper body movements, often in cramped spaces, which can lead to short-term sprains and fatigue as well as long-term injuries.
- Workers face stress and occupational safety and health risks from work organization—often resulting from the way jobs are designed and from organizational policies that shape how the jobs are designed.

While land-based and offshore wind farms share many hazards, the offshore work environment presents some hazards not encountered on a land-based facility. Among them are personnel transfers between vessels and wind turbines; helicopter access to offshore facilities; allisions between vessel and wind turbines; collisions between two or more vessels operating in the same area; falls into water by personnel; diving hazards during foundation installation, cable laying, and regular turbine inspections; evacuation from a wind turbine during a fire, explosion, or severe weather event; and the travel distance to and from shore during emergencies.

Hazards of Offshore Oil and Gas Facilities Relevant to Offshore Wind Farms

Many offshore oil and gas hazards and their associated risks are similar to those of offshore wind farms. Table 2-1 outlines some specific hazards with an indication of whether the overall risk from those hazards to an offshore wind farm worker is similar to, higher than, or lower

TABLE 2-1 Risks from Typical Hazards for an Offshore Wind Farm Worker Compared with Those for an Offshore Oil and Gas Worker

Hazard	Relative Risk (Wind Versus Oil and Gas)	Comment
Electrical injury	Higher	Higher-voltage equipment and all activities related to this equipment.
Personnel transfers	Higher	More boat transfers expected for a worker on offshore wind turbines. Oil and gas platform boat landings and helipads are larger than those for wind monopiles. Helicopters are used more often for oil and gas.
Awkward postures	Higher	Generally, more room to perform tasks is available on oil and gas platforms.
Confined space entry	Similar	Wind turbines have more confined spaces and must be entered more frequently; regardless, confined space entry for both oil and gas and offshore wind carries inherent risk and can have serious consequences.
Falls into water	Similar	Activities in locations where falls into water are likely are similar.
Diving	Similar	Similar activities and frequencies.
Manual material handling	Similar	Similar needs for upgrades or maintenance requiring manual handling of equipment and materials.
Long-term physical wear and tear	Similar	Relatively little climbing is required for offshore oil and gas workers, but shifts and work schedule may be longer.
Mechanical hazards (e.g., pinch points)	Similar	Both installations require work on machines that pose dangers to workers.
Slips and trips	Similar	Common hazards in all workplaces.
Exposure to heat and cold	Similar	Both wind and oil and gas facilities have limited climate-controlled spaces.
Falls from heights	Similar	More climbing and higher climbing is required for activities on wind turbines; however, a higher exposure rate for personnel on oil and gas platforms may exist.
Fire	Lower	Oil and gas facilities process flammable materials.
Explosion	Lower	Oil and gas facilities process flammable materials.
Crane lifts	Lower	Oil and gas facilities generally have permanent cranes that are used more frequently than those that may exist on wind turbines.

(continued on next page)

TABLE 2-1 Risks from Typical Hazards for an Offshore Wind Farm Worker Compared with Those for an Offshore Oil and Gas Worker (*continued*)

Hazard	Relative Risk (Wind Versus Oil and Gas)	Comment
Noise exposure	Lower	Turbines will be shut down when workers are present, but most equipment is not shut down during oil and gas operations.
Chemical exposure	Lower	Oil and gas facilities process material containing a variety of potentially harmful chemicals.
Exposure to weather	Lower	More work in outdoor spaces on oil and gas platforms.

NOTE: Table 2-1 is not intended to be a direct comparison between the two industries, but only an approximation of relative risk. The hazards and risks between offshore wind and offshore oil and gas are not always directly comparable. After installation, offshore wind farms are more like oil and gas production platforms and less like oil and gas drilling rigs.

SOURCE: Generated by the committee.

than the risk to an offshore oil and gas worker. The table represents the committee's judgment on the basis of its experience and provides a comment column with some background to support its conclusion of relative risk.¹³

Certain hazards—chemical exposure, fire, and explosion—associated with the volatile products involved in offshore oil and gas work are less likely with offshore wind. And, because the number of people on a wind turbine at any one time is much smaller than on a drilling platform, the likelihood of a worker being exposed to these hazards is smaller. Common hazards for the oil and gas industry may include falls (particularly down stairs); injuries from cranes and heavy lifts; injuries from being struck by objects; and musculoskeletal injuries from lifting, which may occur less frequently on wind turbines but have similar consequences. Other typical worker injuries including slips and trips and exposure to the weather elements may occur with a similar frequency, but the overall risk of a catastrophic event on an oil and gas platform is higher than what can be expected on a wind farm. For wind farms, the likelihood of a catastrophic event is lower with respect to personnel and environmental

¹³ The committee was unable to collect reliable injury statistics across the different industries to compare and illustrate common or unique hazards.

hazards. The risk of a hazardous materials spill on wind farms is lower because the amounts of such materials (usually lubricating oils and hydraulic fluids) within each wind turbine are small compared with the volume of oil or gas being produced from an offshore platform. In addition, the wind facilities are unmanned, and even when they are occupied, wind turbines are maintained by fewer workers, typically fewer than five.

SUMMARY DISCUSSION

Although land-based and offshore wind turbines follow similar designs and share many characteristics, offshore wind turbines require additional features and modifications for operation in a marine environment. The towers of offshore wind turbines are strengthened to handle the increased forces from waves, and an offshore nacelle is usually pressurized and climate-controlled to protect the internal components from the corrosive marine environment. Working with large installation equipment and moving large turbine components present many challenges. While land-based and offshore operations share development steps, marine and land-based environments present different hazards and risks. As mentioned above, the weather is the deciding factor for offshore work. Since personnel must use a vessel (or possibly a helicopter) to access wind turbines, weather conditions and sea state will determine the accessibility of the wind farm. The dependence on a vessel to access offshore wind turbines creates issues not only when the technician transfers back and forth between the vessel and turbine but also when the worker needs to evacuate or requires spare tools or components. Such dependence does not occur to the same degree during land-based development. Offshore logistics are critical, since vessels must avoid collisions with other vessels and with turbines. Diving operations are sometimes necessary during installation or inspection of wind turbines, which creates additional risk that does not occur onshore. On the basis of this initial comparison, the hazards and associated risks of offshore wind development are likely to be greater than those of land-based wind development. Offshore wind development shares most of the same hazards as land-based wind development but adds those resulting from the marine environment. Chapter 4 discusses potential offshore wind

hazards in more detail and presents relevant regulations, standards, and best practices that might be appropriate.

The oil and gas industry has worked in an offshore environment for decades and has many best practices and standards that would be useful for the offshore wind industry. Chapter 3 introduces regulations and standards that are followed by the oil and gas industry and discusses their relevance to the offshore wind industry. While the oil and gas and wind industries share many offshore hazards, the overall associated risk for oil and gas hazards is greater than for the offshore wind industry. The oil and gas industry works with a more volatile product, and the risk of an explosion or fire on an offshore oil and gas platform is greater than on an offshore wind turbine. Furthermore, offshore drilling platforms are manned and thus pose a greater risk to human life than does the unmanned wind turbine. Chapter 5 discusses the associated risks of the oil and gas industry and the wind industry in more detail.

REFERENCES

Abbreviations

AWEA	American Wind Energy Association
EWEA	European Wind Energy Association
NREL	National Renewable Energy Laboratory
TRB	Transportation Research Board

AWEA. 2009. *AWEA Wind Power Value Chain: Building Links to a Cleaner Energy Future*. Washington, D.C. http://www.awea.org/_cs_upload/learnabout/publications/4144_1.pdf. Accessed March 1, 2013.

AWEA. 2013. AWEA U.S. Wind Industry Fourth Quarter 2012 Market Report. <http://www.awea.org/learnabout/publications/reports/AWEA-US-Wind-Industry-Market-Reports.cfm>. Accessed Feb. 4, 2013.

AWEA. n.d. Anatomy of a Wind Turbine. Fact sheet. http://www.awea.org/issues/supply_chain/Anatomy-of-a-Wind-Turbine.cfm. Accessed Feb. 1, 2013.

AWS Truewind. 2009. *Offshore Wind Technology Overview*. Prepared for the Long Island–New York City Offshore Wind Collaborative. Albany, N.Y. <http://www.lincyoffshorewind.com/PDF/AWS%20Truewind%20Offshore%20Wind%20Technology%20Final%20Report.pdf>.

EWEA. 2009. *Wind Energy—The Facts: A Guide to the Technology, Economics and Future of Wind Power*. <http://www.wind-energy-the-facts.org>.

- Lynn, P. A. 2011. *Onshore and Offshore Wind Energy: An Introduction*. Wiley and Sons, West Sussex, United Kingdom.
- McNeilan, T., and K. R. Smith. 2011. *Seabed Scour Considerations for Offshore Wind Development on the Atlantic OCS*. www.bsee.gov/Research-and-Training/Technology-Assessment-and-Research/Project-656.aspx.
- Melnyk, M., and R. Andersen. 2009. *Offshore Power: Building Renewable Energy Projects in U.S. Waters*. PennWell Corp., Tulsa, Okla.
- Musial, W., and B. Ram. 2010. *Large-Scale Offshore Wind Power in the United States: Assessment of Opportunities and Barriers*. Report TP-500-40745. National Renewable Energy Laboratory, Golden, Colo.
- NREL. 2011. NREL Highlights: NREL Study Finds U.S. Wind Energy Potential Triples Previous Estimates. <http://www.nrel.gov/docs/fy11osti/50860.pdf>. Accessed Feb. 19, 2013.
- Thomsen, K. E. 2012. *Offshore Wind: A Comprehensive Guide to Successful Offshore Wind Farm Installation*. Academic Press, Waltham, Mass.
- TRB. 2011. *Special Report 305: Structural Integrity of Offshore Wind Turbines: Oversight of Design, Fabrication, and Installation*. Transportation Research Board of the National Academies, Washington, D.C. <http://www.trb.org/Publications/Blurbs/165263.aspx>.
- Tveiten, C. K., E. Albrechtsen, J. Heggset, M. Hofmann, E. Jersin, B. Leira, and P. K. Norddal. 2011. *HSE Challenges Related to Offshore Renewable Energy: A Study of HSE Issues Related to Current and Future Offshore Wind Power Concepts*. SINTEF A18107. SINTEF Technology and Society, Trondheim, Norway.

Jurisdiction over and Regulation of Worker Health and Safety

The Outer Continental Shelf Lands Act of 1953 (OCSLA) granted primary authority for worker health and safety on the outer continental shelf (OCS) to the United States Coast Guard (USCG). The Occupational Safety and Health Administration (OSHA) was created in 1970 as the lead agency for all worker health and safety regulation, but offshore oil and gas (nonrenewable minerals) production is a special case, for which the enforcement of health and safety regulations remained with USCG as the lead authority. The 1978 amendments to OCSLA expanded USCG's ability to make and enforce health and safety regulations on the OCS. In 2002, USCG involved the U.S. Department of the Interior's (DOI's) Minerals Management Service (MMS) by authorizing it to conduct safety inspections aboard oil and gas platforms on USCG's behalf.

The introduction of renewable energy regulation (nonminerals) brings about new circumstances and complexities in offshore worker safety. The Energy Policy Act of 2005 amended OCSLA and gave DOI responsibility for regulating renewable energy on the OCS. USCG has determined itself to be a cooperating agency for navigation safety and a subject matter expert for marine safety. This chapter provides a brief overview of the federal agencies that regulate worker health and safety and that have jurisdiction over the OCS. It discusses how these agencies interact and their approaches to regulation. It briefly touches on worker health and safety regulations at the state level and introduces worker health and safety standards and guidance from various relevant sources, both domestic and international.

RELEVANT FEDERAL AGENCIES

Minerals Management Service

DOI created MMS in 1982 to oversee offshore energy production and collection of mineral revenues. The focus of MMS was on oil and gas production. Section 388 of the Energy Policy Act of 2005 amended Section 8 of OCSLA and granted MMS the authority to regulate renewable energy operations on the OCS (*Federal Register* 2011b, 64731). Under this authority, MMS regulated the generation of electricity for forms of energy from sources other than oil and natural gas on OCS facilities. The agency was allowed to issue regulations essential for carrying out its new responsibilities, including those with regard to safety and protection of the environment for any activities completed under its authority (*Federal Register* 2011b, 64731).

On May 19, 2010, after the April 2010 *Deepwater Horizon* accident, Secretary Kenneth Salazar issued Secretarial Order No. 3299 (DOI 2010b), which established three new bureaus within DOI: the Bureau of Ocean Energy Management (BOEM), the Bureau of Safety and Environmental Enforcement (BSEE),¹ and the Office of Natural Resources Revenue (ONRR).² The new bureaus were to be in place by October 2011. On June 18, 2010, Secretary Salazar issued Order No. 3302 (DOI 2010c), which changed the name of MMS to the Bureau of Ocean Energy Management, Regulation, and Enforcement (BOEMRE). That name would remain in effect until the new bureaus were in place. DOI transferred BOEMRE's royalty and revenue management functions to ONRR on October 1, 2010. This action separated revenue collection from leasing and enforcement and eliminated a conflict of interest that could have arisen if all the functions were carried out within the same office. On October 1, 2011, DOI completed the reorganization by separating BOEMRE into the two remaining independent bureaus—BOEM and BSEE—and assigned the existing rules to each. The goals of the reorganization included (a) strengthening the role of BOEM and BSEE in environmental review and analysis and

¹ BOEM and BSEE are both part of the Office of Land and Minerals Management. See <http://www.doi.gov/whowere/orgchart.cfm>.

² ONRR is under DOI's Assistant Secretary and is part of the Office of Policy, Management, and Budget.

Responsibility	Resource Area			
	Oil and Gas and Renewable Energy (after 2005)	Oil and Gas and Renewable Energy	Oil and Gas	Renewable Energy
Promote resource development	MMS	BOEMRE	BOEM	BOEM
Economic analysis				
Leasing				
Environmental assessment		BSEE		
Safety and environmental enforcement				
Revenue collection	ONRR after October 1, 2010	ONRR	ONRR	
	1982 to May 2010	May 2010 to October 1, 2011	Since October 1, 2011	

FIGURE 3-1 DOI's reorganization of MMS (1982 to present), by responsibility and resource area. (SOURCE: Generated by the committee.)

(b) separating the functions of resource development and energy management from the functions of safety and environmental enforcement that had previously coexisted under the old MMS and BOEMRE (*Federal Register* 2011b, 64731).³ The new independent bureaus (see Figure 3-1) were focused on managing and enforcing regulations for oil and gas production. The Energy Policy Act of 2005 placed responsibility for offshore renewable energy with an agency that was accustomed to regulating offshore oil and gas exploration. The next sections briefly introduce the organizational structure and roles of BOEM and BSEE and discuss current regulations for worker health and safety.

Bureau of Ocean Energy Management

BOEM is responsible for managing the development of the nation's offshore resources, including nonrenewable and renewable energy. For nonrenewable energy resources, BOEM's mission involves evaluation,

³ For more information about the BOEMRE reorganization, see BOEMRE 2011. Although MMS no longer exists as an agency, its name is still referred to in some documents.

planning, and leasing; economic analysis; and environmental science and analysis. Its mission also involves all aspects of the Renewable Energy Program (BOEM 2011).⁴ BOEM has three national offices and three regional offices. As part of its role in meeting the mandates of the Energy Policy Act of 2005, BOEM is developing renewable energy regulations that address safety, protect the environment, and coordinate its actions with state and local governments and with other federal agencies. In his presentation to the committee, the Acting Deputy Director of BSEE said that BOEM intended to develop a “regulatory framework for renewable energy activities” that provides “a comprehensive approach to offshore renewable energy initiatives—from preliminary study and lease issuance, to construction and operation, to decommissioning of projects.” The Acting Deputy Director added that BOEM would need to rely on BSEE’s engineering expertise for permit reviews and the inspection processes for renewable energy, since BOEM’s main focus is on developing and managing offshore resources and not on safety and environmental enforcement.⁵

BOEM Office of Strategic Resources

The Office of Strategic Resources assesses potential oil, gas, and other mineral resources on the OCS; inventories oil and gas reserves; develops production projections; and conducts economic evaluations that ensure a fair market return for OCS leases.

BOEM Office of Environmental Programs

The Office of Environmental Programs conducts environmental assessments and reviews (including the National Environmental Policy Act process) for nonrenewable and renewable energy activities during each stage of the offshore energy development planning process. These assessments

⁴ According to the final rule, BOEM will manage the Renewable Energy Program in the near future, but that program will be reorganized and functions will be redistributed between BSEE and BOEM once it is larger and more established (*Federal Register* 2011b, 64459). See <http://www.federalregister.gov/a/2011-22675/p-64>, accessed March 1, 2013.

⁵ Robert LaBelle, BSEE, presentation to the committee, November 30, 2011. Mr. LaBelle currently serves as BOEM’s Science Advisor. At the time of his presentation, he served as Acting Deputy Director of BSEE.

inform BOEM's decisions on environmentally responsible ocean energy and mineral development.

BOEM Office of Renewable Energy Programs

The Office of Renewable Energy Programs is responsible for the granting of leases, easements, and rights-of-way needed for the installation, operations, and decommissioning of all renewable energy activities on the OCS in an “orderly, safe, and environmentally responsible” way. This includes the “Smart from the Start” initiative for facilitating the siting, leasing, and construction of new offshore wind projects off the Atlantic coast (DOI 2010a).

BOEM Regional Offices

BOEM's three regional offices—Gulf of Mexico, Pacific, and Alaska—are integrated into the national programs and help conduct oil and gas resource evaluations, environmental studies and assessments, leasing activities, review of exploration and development plans, fair market value determinations, and geological and geophysical permitting.

Current BOEM Regulations for Worker Health and Safety

As mentioned above, BOEM manages the leasing and environmental reviews of offshore nonrenewable energy-related resources and regulates offshore wind energy production (*Federal Register* 2011b, 64731). Although BOEM does not enforce health and safety or environmental regulations for nonrenewable energy, its mission includes the enforcement of such regulations for offshore wind energy activities on the OCS⁶ and for activities involving the alternative use of OCS facilities (*Federal Register* 2011b, 64459). The brief review of BOEM's organizational structure and responsibilities above indicates the uniqueness of its safety compliance role for renewable energy. In accordance with 30 CFR 585.810

⁶ During the drafting of this report, the sponsor indicated that “there is an expectation that BSEE will conduct safety compliance inspections of offshore renewable energy facilities and this is entirely consistent with the purpose for reorganizing MMS and BOEMRE—to separate the resource management agency (BOEM) from the safety compliance agency (BSEE).” Personal e-mail communication with John Cushing, BSEE, August 21, 2012.

(see Box 1-1), BOEM's Office of Renewable Energy Programs requires the lessee to submit a description of a safety management system (SMS) that meets such goals as ensuring "the safety of personnel or anyone on or near your facilities" and ensuring that workers "who operate . . . facilities are properly trained" (*Federal Register* 2011b, 64774). Chapter 5 further discusses BOEM's SMS and provides suggestions for strengthening and clarifying it.

The regulations in §585⁷ allow BOEM to conduct scheduled and unscheduled inspections of a lessee's facilities and vessels used in operations to verify that all project activities are conducted in compliance with the terms of the lease. The lessee must provide access to all facilities and areas listed on the lease and provide all records of design, installation, operations and maintenance, repairs, or investigations on or related to the project area. The lessee must demonstrate compliance with its own SMS (*Federal Register* 2011b, 64774–64775). Each lessee will also develop and conduct an annual self-inspection plan for all facilities and make the plan available on request. The plan must include such details as type, extent, and frequency of inspections conducted for relevant structures and components and an assessment of structural integrity.⁸ The lessee must submit an annual report listing all facilities inspected over the previous 12 months, the type of inspection used, and a summary of actions taken.

BOEM requires that lessees submit incident reports (as defined in §585.831) promptly for events involving fatalities, evacuation of personnel, fires and explosions, certain vessel collisions, and certain types of property or equipment damage, as well as for any injury that requires personnel to miss the following day of work and for any evacuation that is not related to the weather (*Federal Register* 2011b, 64775). The

⁷ The current study does not discuss the possible need for health and safety protection for projects under research leases on the OCS, although similar SMS requirements may apply. Information can be found in 30 CFR 585.238: Are there any other renewable energy research activities that will be allowed on the OCS? Under this provision, BOEM can issue leases, right-of-way grants, and right-of-use and easement grants to a federal agency or a state on the OCS for renewable energy research activities.

⁸ See *Federal Register* 2011b, 64775; the American Petroleum Institute's API RP 2A-WSD is incorporated by reference.

regulations also provide detailed instructions on reporting an incident (both verbal and written notifications are required) and on what a report should include (see §585.832 and §585.833).

Bureau of Safety and Environmental Enforcement

BSEE,⁹ which is divided into three main offices and three regional offices, enforces safety and environmental regulations for operations with regard to the exploration, development, and production of oil and gas on the OCS. Under the current structure, BSEE's authority does not extend to wind energy power. Major BSEE tasks include permitting and inspecting oil and gas facilities, developing regulations and standards, supporting research on health and safety, reviewing operator oil spill response plans, and operating a newly formed national training center for inspectors.

Office of Offshore Regulatory Programs

BSEE's Office of Offshore Regulatory Programs (OORP) develops standards and regulations for enhancing operational safety and environmental protection for the exploration and development of offshore oil and natural gas on the U.S. OCS and includes four branches. OORP also operates BSEE's National Offshore Training and Learning Center (NOTLC). NOTLC's mission is to enhance the capabilities of BSEE inspectors in enforcing safety and environmental regulations through evolving technical curricula and specialized training that adapts to meet emerging technologies and processes.

Oil Spill Response Division

The Oil Spill Response Division (OSRD) reviews industry oil spill response plans to ensure compliance with regulatory requirements. OSRD is also central in developing policy about, disseminating guidance on, and overseeing oil spill response activities. The division oversees the Unannounced Oil Spill Drill program and works closely with other federal agencies, such as USCG and the Environmental Protection Agency.

⁹ See <http://www.bsee.gov/About-BSEE/index.aspx> or <http://www.bsee.gov/BSEE-Newsroom/BSEE-Fact-Sheets.aspx>, accessed March 1, 2013.

Environmental Enforcement Division

The Environmental Enforcement Division oversees operators' compliance with all applicable environmental regulations and ensures that operators adhere to the stipulations of their approved leases, plans, and permits.

BSEE Regional Offices

BSEE's three regional offices—Gulf of Mexico, Pacific, and Alaska—support its mission by reviewing permit to drill applications and ensuring that safety requirements are met. Personnel from the regional offices also inspect drilling rigs and production facilities, cite noncompliance issues, fine companies for regulatory infractions, and investigate accidents and incidents.

Current BSEE Regulations for Worker Health and Safety

The rules contained in 30 CFR 250 (Oil and Gas and Sulphur Operations in the Outer Continental Shelf) permit BSEE to regulate oil and gas operations on the OCS to prevent injury or loss of life. In an effort to clarify these rules, BSEE often provides industry with a notice to lessees and operators (NTL).¹⁰ Subpart A of 30 CFR 250 presents general requirements for protecting health and safety, maintaining equipment and safe work areas, and using the best available and safest technology. Subpart A sets forth requirements for using and maintaining cranes, for submitting a welding plan that includes qualifications of personnel and procedures that must be followed, and for installing and operating electrical equipment on all facilities. BSEE conducts scheduled and unscheduled inspections on facilities and vessels engaged in operations (including, by agreement, facilities under the jurisdiction of other agencies) to verify that all project activities are conducted in compliance with the terms of the lease and other applicable regulations and laws. Part of the inspection process allows BSEE to examine safety equipment and safe operations with a series of checklist items referred to as potential

¹⁰ NTLs are formal documents that clarify, describe, or interpret a regulation or OCS standard. NTLs provide the lessee with guidance on the implementation of a special lease stipulation or regional requirement or with an explanation of a regulation's scope and meaning, as interpreted by BSEE.

incidents of noncompliance (PINC). PINC checklists¹¹ are inspection items derived from relevant safety and environmental regulations and are used to issue citations in cases of violations.¹² PINCs are more prescriptive and tend to focus on hardware-related issues and whether the hardware is maintained according to a particular standard. As noted by a previous Marine Board study, mechanical failures identified by PINCs are not the main cause of most injuries on offshore oil and gas facilities, which are more often attributed to improper safety procedures or human factors (NRC 1990; TRB 2012). BSEE also has a set of PINCs for renewable energy operations based on the regulations listed in 30 CFR 585.¹³ However, inspection processes that continue to rely on PINCs may not capture improvements in the operational procedures of operators or issues caused by improper safety procedures.

During inspections, the operator must provide access to all facilities and areas listed on the lease and provide all records of design, installation, operations and maintenance, repairs, or investigations on or related to the project area. Under §250.141, the operator may use alternative procedures and equipment as long as a level of safety that equals or surpasses that provided by current requirements or regulations results. BSEE also requires that operators submit incident reports (as defined in §250.187) promptly for events involving fatalities, evacuation of personnel, fires and explosions, certain vessel collisions, and certain types of property or equipment damage. Incident reports are submitted in hard copy (or in digital form if the agency office is equipped to handle it) and should include any injury that requires personnel to miss the following day of work and any evacuation that is not related to the weather.¹⁴

Subparts D, E, and F list requirements for oil and gas well drilling, well completion, and well workover operations. Subpart H includes

¹¹ Lists of all PINCs are found at <http://www.bsee.gov/Inspection-and-Enforcement/Inspection-Programs/Potential-Incident-of-Noncompliance---PINC.aspx>.

¹² <http://www.bsee.gov/Inspection-and-Enforcement/Inspection-Programs/Inspection-Programs.aspx>.

¹³ A complete list of renewable energy PINCs is found at <http://www.bsee.gov/Inspection-and-Enforcement/GLT-pdf.aspx>.

¹⁴ See http://cfr.regstoday.com/30cfr250.aspx#30_CFR_250_Information_and_Reporting_Requirements.

requirements for designing, installing, and operating safety equipment for oil and gas production systems, and Subpart I includes requirements for the design, construction, maintenance, inspection, and assessment of all platforms and related structures located on the OCS. Subpart O contains requirements for implementing a well control and production safety training program and provides details of items that are to be included. Among them are the type of training and the methods used, the length of the training program and the frequency of the training, procedures for evaluating and auditing the program and for maintaining documents and records, and how BSEE will audit and assess a training program.¹⁵

Subpart S requires the lessee to develop, implement, and maintain a safety and environmental management system (SEMS) for oil and gas operations.¹⁶ SEMS is an SMS based on the American Petroleum Institute's (API's) Recommended Practice (RP) 75 ensuring that the lessee "identifies, addresses, and manages safety, environmental hazards . . . during the design, construction, start-up, operation, inspection, and maintenance of all new and existing facilities."¹⁷ SEMS requires the lessee to provide plans for 12 elements including hazards analysis, management of change, safe operating procedures, safe work practices, training, emergency response, incident reporting, auditing, and record keeping.¹⁸ On September 14, 2011, BSEE issued a notice of proposed rulemaking (referred to as SEMS II) that revised SEMS and added elements, which are proposed and have not been implemented (*Federal Register* 2011a, 56683). The introduction of SEMS requirements moved regulation of oil and gas operations toward a more goal-based system, away from the prescriptive approach of PINCs. Chapter 5 discusses the SEMS elements in more detail and evaluates whether the elements included could be used as a model for BOEM's SMS.

¹⁵ See http://cfr.regstoday.com/30cfr250.aspx#30_CFR_SUBPART_O.

¹⁶ For more information on Subpart S, see http://cfr.regstoday.com/30cfr250.aspx#30_CFR_SUBPART_S.

¹⁷ The goals of the SEMS are explained in §250.1901. See http://cfr.regstoday.com/30cfr250.aspx#30_CFR_250p1901.

¹⁸ The complete list of elements is given in §250.1902. See http://cfr.regstoday.com/30cfr250.aspx#30_CFR_250p1902.

United States Coast Guard

USCG has played an important part in U.S. maritime history. It maintains three broad roles—maritime safety, maritime security, and maritime stewardship—composed of 11 missions that are connected and that at times overlap (USCG 2009). All USCG offices and functions are located under the offices of Commandant and Vice Commandant. Among them are Deputy Commandant for Mission Support, Deputy Commandant for Operations, and nine districts distributed between the Atlantic Area and the Pacific Area.¹⁹ The Deputy Commandant for Mission Support manages the life cycle of all USCG assets, including ships, planes, buildings, and information technology, from acquisition through decommissioning. The Deputy Commandant for Operations oversees operational planning, policy, and international engagement at the strategic level and maintains relations with interagency partners and other stakeholders in the development of policy.²⁰

Current USCG Regulations for Worker Health and Safety

The safety of navigation and the safety of life and property on facilities (and vessels that service those facilities) engaged in exploring and exploiting mineral resources on the OCS are regulated by 33 CFR Subchapter N, Outer Continental Shelf Activities, Parts 140 to 147,²¹ but USCG only participates indirectly for activities related to renewable energy operations. Through a memorandum of agreement (MOA), USCG works cooperatively with BOEM to clarify roles and responsibilities related to regulations applied to offshore renewable energy installations (OREIs) and the vessels that service the installations.²² Although the MOA encourages communication and cooperation to avoid overlapping regulations with regard to vessels servicing offshore wind farms,

¹⁹ For more information about USCG organizational structure, see <http://www.dhs.gov/xlibrary/assets/org-chart-uscg.pdf> and <http://www.uscg.mil/top/units/>.

²⁰ Additional information about USCG organizational structure is available at <http://www.uscg.mil/top/units/org.asp>.

²¹ The current version of Subchapter N is available at <http://www.gpo.gov/fdsys/pkg/CFR-2003-title33-vol2/pdf/CFR-2003-title33-vol2-chapI-subchapN.pdf>.

²² The MOA is available at http://www.boemre.gov/pdfs/MOA_USCG_BOEMRE_July_27_2011.pdf.

the MOA is vague and does not fully explain how each agency will handle issues involving worker safety and health. The rules in Subchapter N give USCG responsibility for enforcing a wide range of requirements concerning inspections and general workplace safety and health issues—such as personal protective equipment, lifesaving equipment, and firefighting equipment. In 2002,²³ USCG authorized MMS (now BSEE) to conduct safety inspections aboard oil and gas platforms on its behalf in accordance with 33 CFR Subchapter N and collaborated with MMS in developing procedures and a PINC checklist—corresponding to USCG inspection items—identified as the “personal safety (USCG) PINCs” or “Z-PINCs.”²⁴ At the time of this report, USCG was revising 33 CFR Subchapter N, and substantial updates were expected. Information about these revisions was not available to the committee but could inform safety standards for offshore wind facilities.

Regulations for offshore manned and unmanned barges, including construction barges, are contained in 46 CFR Chapter I, Subchapter I, Cargo and Miscellaneous Vessels, Parts 90 to 105.²⁵ Subchapter I addresses general safety for personnel on board the vessel. It is of particular interest because it contains many of the regulations that will apply to inspected vessels used in constructing offshore wind farms, including vessels that will transport wind farm elements from port to construction site and vessels equipped with cranes.

Regulations for offshore supply vessels (OSVs) supporting both oil and gas and alternative energy operations are contained in 46 CFR Chapter I, Subchapter L, Offshore Supply Vessels, Parts 125 to 134. USCG has determined that these regulations apply to boats involved in construction and transport activities for offshore wind farms.²⁶ In addition, the rules for OSVs apply to lift boats and allow OSVs to carry up to

²³ See *Federal Register* 2002, 5912, <http://www.boemre.gov/federalregister/PDFs/DOT%20Inspection%20Final%20Rule.pdf>.

²⁴ A complete list of Z-PINCs is available at <http://www.bsee.gov/Inspection-and-Enforcement/Inspection-Programs/GLZ-pdf.aspx>.

²⁵ Complete regulations for Subchapter I, Parts 90 to 105, are available at <http://cfr.regstoday.com/46cfr.aspx>.

²⁶ Memorandum on OSV determination; see http://www.brymar-consulting.com/wp-content/uploads/Misc/OSV_110418.pdf.

36 “offshore workers” provided the vessel complies with the provisions of Subchapter L.²⁷

Regulations for safety and health standards for commercial diving operations originating from vessels and facilities under USCG jurisdiction are contained in 46 CFR Chapter I, Subchapter V, Part 197, Subpart B—Commercial Diving Operations, but they are being revised by USCG. The revision of these rules was addressed at a recent National Offshore Safety Advisory Committee meeting, where industry representatives requested that USCG, OSHA, and the U.S. Army Corps of Engineers (USACE) harmonize their commercial diving rules so that diving contractors can more easily meet them and avoid injuries and fatalities (Shaefer 2011).

Another issue involves vessels providing accommodation service on the OCS. As offshore construction and operation have moved farther offshore, companies in the oil and gas business have chartered floating hotels or “floatels” to house the workers. Similar arrangements may be made for future offshore wind farm operations in the United States. To address the safety of these facilities, USCG requested public comment on appropriate standards for their design, construction, and operation. Although development of final rules may take several years, the standards would apply to wind farm operations once they go into effect (*Federal Register* 2012, 5039).²⁸

USCG and International Safety Management Code

The International Safety Management (ISM) Code is a mandated SMS of the International Maritime Organization for vessels subject to the International Convention for the Safety of Life at Sea, 1974, and is administered in the United States by USCG. The ISM Code establishes safety management goals and requires the shipowner or ship operator

²⁷ For more information, see <http://www.uscg.mil/hq/cg5/nvic/pdf/1991/n8-91.pdf>, <http://www.uscg.mil/d8/prevention/docs/1997Policy/D8m97-36.pdf>, and <http://www.uscg.mil/d8/prevention/docs/1998Policy/D8m98-21.pdf>. NVIC stands for Navigation and Vessel Inspection Circular, a document providing guidance concerning enforcement or compliance with USCG safety regulations or programs. Although an NVIC does not have the force of law, it can indicate how USCG will enforce certain regulations.

²⁸ The request for public comments is available at <https://federalregister.gov/a/2012-2119>.

to implement an SMS. The ISM guidelines establish basic principles for verifying that a ship operator's SMS complies with the ISM Code and for issuing and verifying a document of compliance (DOC). USCG implements and enforces the ISM Code for U.S.-flag vessels and for foreign-flag vessels entering U.S. ports and is authorized to board a vessel and to determine the existence of a valid DOC or safety management certificate.²⁹ The U.S. regulations that implement the ISM Code are found in 33 CFR Part 96, and detailed guidelines for ISM Code enforcement with regard to foreign-flag vessels are contained in Navigation and Vessel Inspection Circular (NVIC) 04-05.³⁰

Subchapter M, Inspection of Towing Vessels

A rule that applies to U.S.-flag vessels and that contains regulations for a comprehensive SMS has been proposed as 46 CFR Chapter I, Subchapter M, Inspection of Towing Vessels, Parts 136 to 144. The towing safety management system (TSMS) will include company and vessel compliance policies, vessel standards, and inspection procedures for new and existing towing vessels. The TSMS would allow companies flexibility in customizing their approach to meeting the rule's requirements. The TSMS will provide an organized and reviewable document of a company's health and safety policies and procedures and will describe how its vessels and employees would comply with all applicable requirements prescribed in this new subchapter, including lines of communication, emergency response procedures, contractor management, and management review procedures. A company's existing SMS that is fully compliant with the ISM Code requirements, as found in 33 CFR Part 96, Rules for the Safe Operation of Vessels and Safety Management Systems, will be considered compliant with the proposed TSMS requirements.

To achieve compliance, a company must select one of two options. The first involves developing and implementing a TSMS and using a third-party auditor approved by USCG. The company has 2 years to create the TSMS and have the third party approve and issue a TSMS

²⁹ See TRB 2012, pp. 35–36, for additional details about USCG enforcement of the ISM Code.

³⁰ NVIC 04-05 cancels NVIC 04-98. See <http://www.uscg.mil/hq/cg5/nvic/pdf/2005/NVIC%2004-05.pdf> for more information.

certificate. The company would then have 4 more years to bring all vessels under the TSMS before receiving a certificate of inspection (COI) from USCG.

The second compliance option occurs if a company decides not to develop a TSMS (or if no TSMS is developed within the first 2 years after the rule is implemented). The company must submit to an alternative USCG inspection for 25 percent of its vessels every year until all its vessels comply. One hundred percent compliance must be achieved before the company will receive the COI for its vessel from USCG. For both options, USCG will allow companies to distribute the burden of implementation over multiple years.

COIs would be issued by USCG to vessels on the basis of evidence of vessels' compliance with the subchapter. USCG oversees the third-party organizations that conduct TSMS audits and surveys, and USCG will conduct compliance examinations at least once every 5 years, along with additional random compliance checks based on risk, which is to be determined by an analysis of management and vessel safety histories.

Auditing will be an integral part of the proposed TSMS. Internal and external audits will be incorporated, in a manner similar to audits associated with the ISM Code. Internal audits would be conducted by or on behalf of an organization's management, and external audits are to be conducted by an approved third-party auditor. Before an external audit, an operator must notify USCG, which may require one of its representatives to be present during the audit and could require an audit of its own. The results of any external audit must be submitted to USCG.

Discussions beginning in early 2003 between USCG and the leadership of the American Waterways Association, the national trade association for the tugboat, towboat, and barge industry, led to the proposed Subchapter M. The proposed rule serves as an example of an industry working with its regulator to advance safety through the implementation of an SMS requirement by providing flexibility to vessel owners to demonstrate compliance with the regulations.

MOA Between BOEM and USCG

As mentioned earlier, an MOA was instituted to identify and clarify the roles and responsibilities of BOEMRE (now BOEM) and USCG for

OREIs on the OCS in the issuance of leases and the approval of site assessment plans, general activity plans, and construction and operations plans. In the MOA, an OREI is defined as “a facility located on the OCS that produces or supports the production, transportation, or transmission of energy from sources other than oil and gas.”³¹ While USCG is jointly responsible with BOEMRE (now through BSEE) for enforcing the safety and environmental regulations applicable to oil and gas facilities on the OCS, the current MOA for OREIs only sets a framework for communication and cooperation between BOEMRE (now BOEM) and USCG to encourage interaction throughout the OREI process and to avoid overlapping and duplicative regulations with regard to vessels servicing OREIs. However, the MOA does not clearly address the health and safety of personnel during the interaction between a vessel and a facility for wind farms on the OCS.

Occupational Safety and Health Administration

The Occupational Safety and Health Act of 1970 (OSH Act)³² created OSHA. OSHA is located in the U.S. Department of Labor and is responsible for developing and enforcing workplace safety and health regulations for general industry (29 CFR 1910), the construction industry (29 CFR 1926), and the maritime and shipyard industry (29 CFR 1915, 1917, and 1918). OSHA is organized into eight directorates at the national level and has 10 regional offices.³³ The directorates include Evaluation and Analysis, Standards and Guidance, Administrative Programs, Cooperative and State Programs, Technical Support and Emergency Management, Enforcement Programs, Construction, and Training and Education.

With the creation of OSHA, Congress intended “to assure safe and healthful working conditions for working men and women by setting

³¹ The entire MOA is available at http://www.boemre.gov/pdfs/MOA_USCG_BOEMRE_July_27_2011.pdf.

³² The OSH Act also created the National Institute for Occupational Safety and Health, which is part of the Centers for Disease Control and Prevention in the Department of Health and Human Services and is responsible for conducting research and making recommendations for the prevention of work-related injury and illness.

³³ OSHA's organizational structure is described at <http://www.osha.gov/html/OSHAorgchart.pdf>.

and enforcing standards and by providing training, outreach, education and assistance.³⁴ Section 5 of the OSH Act requires employers not only to comply with all health and safety regulations issued in accordance with the act but also to provide a workplace that is free of recognized hazards. The latter requirement is referred to as the General Duty Clause.³⁵

Section 4(a) of the OSH Act gives OSHA jurisdiction over private-sector employers and employees in all 50 states, the District of Columbia, and other U.S. jurisdictions (Box 3-1), either directly through the federal OSHA or through an OSHA-approved state program. Twenty-seven states and territories operate their own programs³⁶ under their own statutes, but the state programs must be at least as effective as the federal OSHA program.³⁷ Under Section 4(a), OSHA's authority includes all U.S. navigable waters (defined as state territorial seas or U.S. inland waters) and the OCS lands, which begin 3 nautical miles from the coastline (9 nautical miles for Texas and the Gulf Coast of Florida).³⁸ However, where other federal agencies have statutory authority for workplace safety and health and where they have chosen to exercise this authority (Box 3-1), OSHA does not have jurisdiction under Section 4(b)(1).³⁹ USCG has primary enforcement duties for health and safety regulations on the OCS. As discussed above, BSEE shares health and safety regulatory authority with USCG for oil and gas operations on the OCS (see *Federal Register* 2002, 5912), and OSHA has acknowledged this authority in Compliance Directive (CPL) 02-01-047.⁴⁰

³⁴ From OSHA's mission statement. See <http://www.osha.gov/about.html>.

³⁵ A complete description of the General Duty Clause is given at http://www.osha.gov/pls/oshaweb/owadisp.show_document?p_table=OSHACT&p_id=3359.

³⁶ See <http://www.osha.gov/dcsp/osp/index.html>. Five of these 27 state programs are limited to the nonfederal public sector; the federal OSHA has jurisdiction over the private sector in these five states.

³⁷ See http://www.osha.gov/OSHA_FAQs.html for more detail.

³⁸ See CPL 02-01-047, http://www.osha.gov/OshDoc/Directive_pdf/CPL_02-01-047.pdf.

³⁹ OSHA has published guidance and a legal commentary on this policy. See http://www.osha.gov/pls/oshaweb/owadisp.show_document?p_id=19819&p_table=INTERPRETATIONS. Other examples include the Mine Safety and Health Administration at all mining and mineral processing operations in the United States and the Department of Energy at its nuclear energy and weapons facilities and national laboratories subject to the Atomic Energy Act.

⁴⁰ See OSHA 2010, p. 24, Summary Safety and Health Coverage Matrix, and Appendix E, Memorandum of Understanding between USCG and OSHA. OSHA CPLs provide a better understanding of OSHA requirements and help to clarify compliance with an OSHA standard or to instruct compliance officers when they inspect employer compliance with many OSHA standards.

BOX 3-1

OSHA Jurisdiction on the OCS and Applicability of the OSH Act

Section 4(a) states that the provisions of the OSH Act “shall apply with respect to employment performed in a workplace in a State, the District of Columbia, the Commonwealth of Puerto Rico, the Virgin Islands, American Samoa, Guam, the Trust Territory of the Pacific Islands, Wake Island, Outer Continental Shelf Lands defined in the Outer Continental Shelf Lands Act, Johnston Island, and the Canal Zone. The Secretary of the Interior shall, by regulation, provide for judicial enforcement of this Act by the courts established for areas in which there are no United States district courts having jurisdiction.”

Section 4(b)(1) states that “nothing in this Act shall apply to working conditions of employees with respect to which other Federal agencies, and State agencies acting under section 274 of the Atomic Energy Act of 1954, as amended (42 U.S.C. 2021), exercise statutory authority to prescribe or enforce standards or regulations affecting occupational safety or health.”

For the complete text of Section 4, see http://www.osha.gov/pls/oshaweb/owadisp.show_document?p_table=OSHACT&p_id=3358.

Current OSHA Regulations for Worker Health and Safety

All of OSHA’s health and safety regulations are contained in 29 CFR.⁴¹ Although duplicate regulations may exist in various subparts, the standards relevant to worker safety for offshore wind farms are found in Parts 1910 (general industry); 1915, 1917, and 1918 (maritime); and 1926 (construction).

⁴¹ All parts of 29 CFR are available at http://www.osha.gov/pls/oshaweb/owasrch.search_form?p_doc_type=STANDARDS&p_toc_level=0.

The general industry standards in 29 CFR 1910 contain numerous prescriptive rules covering almost all hazards. Among them are those associated with walking surfaces and ladders (Subpart D), means of egress (Subpart E), general environment controls—for example, confined space entry (1910.146) and lockout or tagout (1910.147)—in Subpart J, fire protection (Subpart L), electric power generation as in 1910.269, and commercial diving operations in Subpart T.

The maritime standards consist of three parts: 29 CFR 1915, 1917, and 1918.

- Rules for all shipyard employment are contained in 29 CFR 1915. They include provisions for shipbuilding, ship repairing, and ship breaking. Rules with regard to confined and enclosed spaces (Subpart B), scaffolds and ladders (Subpart E), and general working conditions (Subpart F) are encompassed.
- Aspects of marine terminal work are addressed by 29 CFR 1917. The movement (loading and unloading) of cargo or materials within the terminal area accomplished with the use of shore-based cranes, derricks, or other cargo-handling equipment is included.
- Rules that apply to longshoring operations and tasks associated with working aboard vessels, including general conditions, accessing the vessel, and handling cargo, are set forth by 29 CFR 1918.

The construction standards in 29 CFR 1926 apply specific rules to employers in the construction industry, although the general industry rules in Part 1910 remain in effect. The regulations in Part 1926 cover personal protective and life saving equipment (Subpart E), fire protection and prevention (Subpart F), fall protection (Subpart M), commercial diving (Subpart Y), and cranes and derricks (Subparts CC and DD).

OSHA Safety Management

OSHA is known for establishing prescriptive regulations for worker health and safety, but the agency has pursued more goal-based practices, including process safety management (PSM) and a voluntary protection program (VPP), both of which are explained below.

Process Safety Management

The Process Safety Management of Highly Hazardous Chemicals standard is located in 29 CFR 1910.119 (and 1926.64). As the title suggests, it is based on controlling the release of hazardous chemicals to protect worker health and safety. The rules, which were initiated in 1992, are designed for facilities and operations with a significant risk of hazardous chemical release, fire, or explosion. They include procedures and management practices to prevent or reduce the consequences of release of toxic, flammable, explosive, or reactive liquids and gases (listed in 1910.119, Appendix A). The PSM standard in 1910.119 lists 14 elements, which are similar to those of other SMSs: (a) employee participation, (b) process safety information, (c) process hazard analysis, (d) operating procedures, (e) training, (f) contractor safety, (g) prestartup safety review, (h) mechanical integrity, (i) hot work program, (j) management of change, (k) incident investigation, (l) emergency planning and response, (m) compliance audits, and (n) trade secrets. Appendix C provides guidance and examples for achieving the performance goals of the standard. The PSM regulation is similar to BSEE's SEMS⁴²—discussed earlier—in that both systems include measures for ensuring safe operations, such as comprehensive procedures and management practices for protecting workers and the environment.⁴³

Voluntary Protection Program

VPP, primarily a recognition program, was established by OSHA in 1982 to identify and promote effective health and safety management systems of private industries and federal agencies that maintain illness and injury rates below the national average. Approval into VPP requires implementing a comprehensive health and safety management system and agreeing to a thorough on-site evaluation by an external team of health and safety professionals. A participant's SMS must document the following four elements and their subelements: (a) management leadership

⁴² See TRB 2012, pp. 46–51, for more information comparing PSM and SEMS.

⁴³ The PSM program is OSHA's only rule that has the same basic elements as an SMS. OSHA is considering a second rule related to a health and safety management system and based on its voluntary guidelines published in 1989—Safety and Health Program Management Guidelines (*Federal Register* 1989, 3904).

and employee involvement, (b) work site analysis, (c) hazard prevention and control, and (d) safety and health training. Participation of both management and employees and annual self-evaluations are among the VPP requirements. VPP participants are reevaluated every 3 to 5 years, and as long as they maintain their VPP status, they are exempt from OSHA programmed inspections.⁴⁴ VPP employers must show that their safety process is effective, typically by demonstrating that their injury experience is below the national average for a comparable workplace.

FEDERAL JURISDICTION FOR WIND FARM WORKER HEALTH AND SAFETY

Jurisdictional issues and enforcement responsibilities facing the federal government with regard to wind farm worker health and safety were discussed during an April 2012 meeting of representatives from BSEE, USCG, and OSHA. The goals of the meeting included defining all the relevant phases of the offshore wind farm life cycle and defining the authority, responsibility, and relevant guidance for each phase. In addition, several follow-up action items were discussed.

One of the most important determinations of the meeting was that jurisdiction for offshore worker health and safety on wind farms resides in BOEM's Office of Renewable Energy Programs (see Table 3-1 for a summary of jurisdictional responsibility) and that DOI would provide a letter stating its intent to exercise its statutory authority over enforcement of health and safety regulations, thus preempting OSHA. Furthermore, BOEM would regulate by requiring an SMS.⁴⁵ DOI has determined that the SMS required in the current regulations should cover all activities at all facilities described in the approved site assessment plan, construction and operations plan, and general activities plan, including activities occurring at onshore facilities.⁴⁶

⁴⁴ See http://www.osha.gov/OshDoc/Directive_pdf/CSP_03-01-003.pdf for additional information concerning VPP.

⁴⁵ Ron Beck, USCG, and John Cushing, BSEE, May 30, 2012, teleconference with the committee discussing the April 18 meeting of BSEE, USCG, and OSHA representatives.

⁴⁶ Personal communication, John Cushing, BSEE, September 24, 2012. This determination is consistent with how the current regulation (§585.811) is written.

TABLE 3-1 Summary of Health and Safety Jurisdiction for Offshore Wind Farms

Regulator	Jurisdiction for Offshore Wind Farms	
	State Waters and the Great Lakes	OCS
BOEM ^a	No jurisdiction. ^b	Jurisdiction of wind farms on the OCS and a requirement for an SMS for wind farms on the OCS. The scope of the SMS should discuss all activities and all facilities, regardless of jurisdiction.
BSEE ^c	No jurisdiction.	No jurisdiction for wind farms on the OCS; jurisdiction only for oil and gas operations and a requirement for a SEMS for oil and gas on the OCS.
USCG ^d	Safety of navigation, life, and property on inspected and certain other vessels, but not for wind farms in state waters or on the Great Lakes.	Safety of navigation, life, and property on vessels and facilities pertaining to mineral (nonrenewable) resources on the OCS, but interaction between vessel and facility for wind farms on the OCS is still unclear.
OSHA ^e or state OSHA	Jurisdiction and regulations for specific hazards of offshore wind farms in state waters and the Great Lakes (and on the OCS—unless another agency exercises statutory authority).	No jurisdiction; BOEM intends to exercise statutory authority.
Federal Energy Regulatory Commission	No jurisdiction; no health and safety responsibilities or regulations for offshore wind farms.	No jurisdiction; no health and safety responsibilities or regulations for wind farms on the OCS; commission's jurisdiction only includes hydrokinetic projects on the OCS.
USACE	No jurisdiction, but does have health and safety regulations for its own contractors.	No jurisdiction, but does have health and safety regulations for its own contractors.

^aBOEM has jurisdiction over enforcing health and safety regulations for wind farms on the OCS but does not have the necessary enforcement staff. BOEM will consult with BSEE with regard to enforcement.

^bBOEM does not have jurisdiction in state waters. However, according to Subpart H of 30 CFR 585, BOEM's SMS should discuss all activities and all facilities described in and conducted under an operator's site assessment plan, construction and operations plan, or general activities plan, regardless of jurisdiction (see also Finding 6).

^cBSEE is expected to conduct safety compliance inspections of offshore renewable energy facilities by 2014.

^dUSCG regulates the health and safety of seamen on inspected vessels, regardless of jurisdiction, but the responsibility for interaction between vessel and facility still needs to be resolved between USCG, BOEM, and BSEE.

^eOSHA regulates health and safety of personnel (nonseamen) in state waters and on the Great Lakes, but not on the OCS.

SOURCE: Generated by the committee.

Representatives at the April 18 meeting also determined that the existing memorandum of understanding between OSHA and USCG should be revised given the likely introduction of OREIs in state waters and the likelihood of shared responsibility for investigations. Similarly, the MOA between USCG, BOEM, and BSEE should reflect the likelihood of shared responsibility for investigations. In addition, a trilateral agreement between DOI, USCG, and OSHA for any perceived violation would encourage collaboration across regulators and geographical jurisdictions.⁴⁷

OTHER FEDERAL AGENCIES

U.S. Army Corps of Engineers

USACE manages public engineering services in missions around the world for both military and civil works projects, and its programs have attained a safety record that is below the national average for accidents.⁴⁸ USACE publishes a comprehensive set of safety standards found in the *Safety and Health Requirements Manual* [Engineering Manual (EM) 385-1-1].⁴⁹ This manual is required in all Department of Defense construction contracts, and all contractors conducting business with USACE must adhere to its technical standards. EM 385-1-1 was first published in 1941, and many stakeholders have helped to develop it over time through the use of best practices and lessons learned.⁵⁰

EM 385-1-1 contains health and safety requirements for high-hazard issues pertaining to cranes and hoisting equipment (Section 16), fall protection (Section 21), arc flash (Section 11), controls for hazardous energy—lockout and tagout (Section 12), and diving operations (Section 30) (USACE 2008). All contractors must develop and submit a primary safety program as outlined in the Accident Prevention Plan, which must be accepted by USACE before work may begin (USACE

⁴⁷ Ron Beck, USCG, and John Cushing, BSEE, May 30, 2012, teleconference with the committee discussing the April 18 meeting of BSEE, USCG, and OSHA.

⁴⁸ Richard Wright, USACE, December 1, 2011, presentation to the committee.

⁴⁹ The manual is undergoing a revision. Its expected release date is 2013.

⁵⁰ Richard Wright, USACE, December 1, 2011, presentation to the committee.

2008). This document defines how the contractor will manage its safety program during the contract and includes parts on responsibilities and lines of authority, training policies, safety and health inspections, risk management processes, accident reporting, auditing, and specific technical safety plans.⁵¹

Under Section 10 of the Rivers and Harbors Act, USACE has authority for permitting the construction of any obstructions, such as artificial islands, installations, or structures, in U.S. navigable waters and on the seabed of the OCS but does not have authority for the operations of these obstructions. In addition, USACE does not have authority over offshore wind farm worker safety.⁵²

Federal Energy Regulatory Commission

According to the memorandum of understanding between the Federal Energy Regulatory Commission (FERC) and MMS, MMS (now BOEM) has jurisdiction over issuing leases, easements, and rights-of-way for hydrokinetic projects on the OCS, while FERC has jurisdiction over licensing and issuing exemptions only for hydrokinetic projects on the OCS.⁵³ FERC does not have oversight authority over other renewable energy projects, such as wind and solar on the OCS—that authority belongs to BOEM.⁵⁴ The committee’s understanding is that FERC has authority over the licensee (developer) of the hydrokinetic project but not the contractor. The licensee would require its contractor to perform work in accordance with pertinent safety requirements (e.g., those of OSHA and the National Fire Protection Association), but FERC does not require worker safety plans, nor does it review them.⁵⁵ As hydrokinetic projects on the OCS are planned and authorized, BOEM and FERC are expected to provide more information and requirements relating to design, installation, operations, and compliance.

⁵¹ Richard Wright, USACE, December 1, 2011, presentation to the committee.

⁵² Richard Wright, USACE, December 1, 2011, presentation to the committee.

⁵³ See <http://www.ferc.gov/legal/maj-ord-reg/mou/mou-doi.pdf>.

⁵⁴ For updated guidelines on agency roles and jurisdiction, see also *BOEM/FERC Guidelines on Regulation of Marine and Hydrokinetic Energy Projects on the OCS*, Version 2, July 19, 2012. <http://www.ferc.gov/industries/hydropower/gen-info/licensing/hydrokinetics/pdf/mms080309.pdf>.

⁵⁵ Paul Shannon, FERC, November 30, 2011, presentation to the committee.

STATE OSHA PROGRAMS AND REGULATIONS IN NONFEDERAL WATERS

OSHA and state OSHA programs do not have specific offshore wind farm regulations. Instead, they would apply current regulations, depending on the nature of the work performed and the hazards presented. For offshore wind farms located in U.S. navigable waters, including state territorial seas and U.S. inland waters, OSHA would most likely apply rules from its construction standards (29 CFR 1926), general industry standards (29 CFR 1910), and maritime standards (29 CFR 1915, 1917, and 1918).

Of the states that operate their own OSHA-approved state programs, only California, Minnesota, Vermont, and Washington assert health and safety authority over some aspects of private-sector maritime employment, but this authority has been limited to shore-based activities and not to vessels or workplaces on or adjacent to U.S. navigable waterways (see OSHA 2010). For commercial diving operations, California, Michigan, Oregon, and Washington have published state standards that differ from the federal standards in 29 CFR 1910, Subpart T, Commercial Diving Operations (see OSHA 2011).

With the exception of OSHA's PSM in 29 CFR 1910.119, OSHA does not have a general health and safety program rule that would be comparable with an SMS or a SEMS. Among state OSHA programs, California has the most fully developed health and safety program rules, in addition to its general industry and construction rules. California's Injury and Illness Prevention Program rule has existed since 1991 and requires many of the elements of other SMSs (e.g., management commitment, safe work practices, scheduled inspections, and hazard identification), but not the risk assessment common to many SMSs (see Title 8, Section 3202, California Code of Regulations).

In addition, the California State Lands Commission requires oil and gas operators to conduct a Safety Assessment of Management Systems (SAMS) assessment program based on API RP 75. The safety assessments rely on best management practices for high-risk industries. They include such elements as management and organizational issues, hazards analysis, management of change, operating procedures, safe work practices,

training and selection, mechanical integrity, emergency response, and investigation and audit.⁵⁶

Washington State has an accident prevention program requiring such elements as a description of a health and safety program and its procedures, the reporting of unsafe work conditions, hazard identification, and health and safety training programs (see Washington Administrative Code 296-800-140).

Although offshore wind farms under California OSHA or Washington State OSHA jurisdiction could be covered by their safety and health program rules in addition to their construction and general industry rules, federal OSHA, with coordination from USCG, will likely assert jurisdiction over offshore wind farms in all state waters, at least during the initial phases.⁵⁷

REGULATORY APPROACHES: PRESCRIPTIVE AND GOAL-BASED

Regulatory approaches can be prescriptive and specific or goal- or performance-based. Prescriptive rules tend to provide clear statements and details about how to comply with a requirement and ensure a higher degree of consistency in compliance. Prescriptive regulations create a “bright line” of enforcement, so regulated parties know with some certainty whether they are in compliance. The development of prescriptive safety rules is sometimes a response to observed trends within an industry or to a specific event or hazard. Agencies develop requirements for equipment and operations and then use inspections or audits to determine compliance. Many regulations are prescriptive in nature. An example is the following in 30 CFR 250.114:

How must I install and operate electrical equipment?

The requirements in this section apply to all electrical equipment on all platforms, artificial islands, fixed structures, and their facilities.

⁵⁶ For more information about the SAMS program, see TRB 2012, p. 54, and the SAMS website, http://www.slc.ca.gov/division_pages/MFD/MFD_Programs/SAMS/SAMS.html.

⁵⁷ Ron Beck, USCG, and John Cushing, BSEE, May 30, 2012, teleconference with the committee discussing the April 18 meeting of BSEE, USCG, and OSHA.

(a) You must classify all areas according to API RP 500, Recommended Practice for Classification of Locations for Electrical Installations at Petroleum Facilities Classified as Class I, Division 1 and Division 2, or API RP 505, Recommended Practice for Classification of Locations for Electrical Installations at Petroleum Facilities Classified as Class I, Zone 0, Zone 1, and Zone 2.

USCG has the following prescriptive requirement for rails and guards in 46 CFR 92.25-5:

§92.25-5 Where rails required

(a) All vessels shall have efficient guard rails or bulwarks on decks and bridges. The height of rails or bulwarks shall be at least 39½ inches from the deck except that where this height would interfere with the normal operation of the vessel, a lesser height may be approved by the Commandant. At exposed peripheries of the freeboard and superstructure decks, the rails shall be in at least three courses, including the top. The opening below the lowest course shall not be more than 9 inches. The courses shall not be more than 15 inches apart. In the case of ships with rounded gunwales the guard rail supports shall be placed on the flat of the deck. On other decks and bridges the rails shall be in at least two courses, including the top, approximately evenly spaced. If it can be shown to the satisfaction of the Officer in Charge, Marine Inspection, that the installation of rails of such height will be unreasonable and impracticable, having regard to the business of the vessel, rails of a lesser height or in some cases grab rails may be accepted and inboard rails may be eliminated if the deck is not generally accessible.

OSHA requires the following for fall protection:

1926.501(b)(2)(ii) Each employee on a walking/working surface 6 feet (1.8 m) or more above a lower level where leading edges are under construction, but who is not engaged in the leading edge work, shall be protected from falling by a guardrail system, safety net system, or personal fall arrest system. If a guardrail system is chosen to provide the fall protection, and a controlled access zone has already been established for leading edge work, the control line may be used in lieu of a guardrail along the edge that parallels the leading edge.

The following are required for the rungs and cleats on fixed ladders by 1910.27(b)(1):

1910.27(b)(1)(i) All rungs shall have a minimum diameter of three-fourths inch for metal ladders, except as covered in paragraph (b)(7)(i) of this section and a minimum diameter of 1½ inches for wood ladders.

1910.27(b)(1)(ii) The distance between rungs, cleats, and steps shall not exceed 12 inches and shall be uniform throughout the length of the ladder.

Although prescriptive regulations are useful and necessary, they have several shortcomings. It is impossible to draft rules to address all the possible hazards that contribute to major accidents, which are complex events. Even when necessary rules are identified, the regulatory process can take many years, and by the time prescriptive rules emerge from this process, they may be incomplete or inappropriate because circumstances or technologies have changed. As noted in the Macondo well report, regulators often struggle to keep up with industry when technologies are advancing rapidly (NAE and NRC 2012, 112). MMS's prescriptive regulatory system did not keep up with the technological advances occurring in the oil and gas industry.

Goal-based or performance-based approaches, such as an SMS, are more flexible than prescriptive regulations and generally specify a required outcome instead of steps that the operator must follow for compliance. The flexibility allows the operator to manage the risk for all identified hazards and to choose the best method for achieving the desired safety outcome. BSEE's SEMS requirement and OSHA's PSM standards (described above) are examples of goal- or performance-based approaches. Such approaches have both advantages and disadvantages in comparison with prescriptive requirements. Performance-based rules sometimes provide regulated parties with too much flexibility, and they may not know whether they are in compliance until they are inspected. Flexibility can also contribute to inconsistent enforcement. One of the advantages of performance-based rules is their focus on clearly stated safety goals and a documented process for reaching those goals. A well-conceived SMS enhances consistent and effective communication for all workers (including management, operators, and subcontractors) concerning work requirements and expectations and promotes continual improvement. An SMS also supports independent assessment of operations and conformance to expectations, including a commitment to health and safety, regardless of advances in technology within an industry (NAE and NRC 2012).

WORKER HEALTH AND SAFETY GUIDANCE FROM OTHER SOURCES

Health and safety guidance can originate from sources other than regulations and can include standards, guidelines, and RPs. Such voluntary consensus documents usually are detailed and technical in nature, but they do not have statutory authority, although they can be incorporated by reference into a rule or regulation. The following subsections introduce guidance from several sources, both domestic and international.

ANSI/AIHA/ASSE Z10-2012 Occupational Health and Safety Management Systems

With the oversight of the American National Standards Institute (ANSI),⁵⁸ the American Industrial Hygiene Association (AIHA)⁵⁹ developed and released a voluntary consensus standard for occupational health and safety management systems, ANSI/AIHA Z10-2005. That standard is made up of basic concepts of management leadership and employee participation, planning, implementation and operation, evaluation and corrective action, and management review. The standard is an effective tool for continually improving occupational health and safety performance and uses the quality concept of plan-do-check-act. ANSI has recently approved a revised version for 2012. Before 2012, AIHA had been the secretariat of the Z10 Accredited Standards Committee (ASC Z10), but it has relinquished all of its secretariats to the American Society of Safety Engineers (ASSE),⁶⁰ which is now the ASSE Z10 ASC secretariat and copyright holder of both the 2005 and 2012 versions of the Z10 standard (ASSE 2012).

⁵⁸ ANSI oversees the development and use of “voluntary consensus standards and conformity assessment systems” for almost every U.S. industry by accrediting the procedures of standards development organizations, which work to develop standards through ANSI’s “requirements for openness, balance, consensus and due process.”

⁵⁹ AIHA serves the needs of occupational and environmental health and safety professionals who practice industrial hygiene in industry, government, labor, academic institutions, and independent organizations.

⁶⁰ ASSE represents safety, health, and environmental professionals from many industries around the world.

American Wind Energy Association

The American Wind Energy Association (AWEA) is a national trade association representing wind energy interests in the United States and wind advocates from around the world. It provides information about the wind industry to members of Congress, government officials, the media, and the general public. Under the authority of ANSI, AWEA is an accredited standards developer for consensus wind energy standards documents in the United States. It has released *AWEA Large Turbine Compliance Guidelines: AWEA Offshore Recommended Practices (2012): Recommended Practices for Design, Deployment, and Operation of Offshore Wind Turbines in the United States* (AWEA 2012). In addition, the AWEA Safety Committee, through its Offshore Safety Subcommittee, is drafting *Health and Safety Best Practice Guidelines for Offshore Wind Energy*.⁶¹ AWEA is collaborating with ASSE in drafting the standard “Safe Construction and Demolition of Wind Generation/Turbine Facilities” (A10.21-201x). ASSE expects to circulate a public draft of the document in 2013.

The Training and Education Safety Subcommittee has produced an orientation video, *Introduction to Windfarm Safety*, which shows the hazards of wind farm work. The subcommittee has created an *Introduction to Safety: Wind Energy* training course, which will be an introduction to construction safety on wind energy projects and will include an instructor’s manual and a student manual covering eleven topics: (a) introduction to OSHA, (b) walking and working surfaces, (c) emergency action plan, (d) electrical, (e) personal protective equipment, (f) hazard communication, (g) material handling, (h) safety and health, (i) ergonomics, (j) fall protection, and (k) confined space. AWEA will seek OSHA Training Institute approval for the course material. The subcommittee is also creating a course training manual for a qualified electrical worker presenting basic guidelines and elements that all companies should include in their training. The material will include an orientation video on electrical safety for new employees.⁶²

⁶¹ Presentation at AWEA Offshore WindPower 2012, Offshore Safety Subcommittee Meeting, Virginia Beach, Virginia, October 9–11, 2012.

⁶² Presentation at AWEA WindPower 2012, Safety Committee Meeting, Atlanta, Georgia, June 4–6, 2012.

Through its national alliance with OSHA, AWEA developed and coordinated a 3-day training class for OSHA health and safety compliance officers from around the country to improve their understanding of the wind energy industry. The purpose of the training was to help compliance officers understand how to climb a wind turbine, how the components inside the nacelle operate, and how to perform a self-rescue from the tower.⁶³ The goal of the training and the alliance is to showcase industry best practices and to develop a better compliance process among the alliance participants.

UK Health and Safety Executive

The Health and Safety Executive (HSE) is Great Britain's regulator for all work-related health, safety, and illness issues and uses the Health and Safety at Work etc. Act 1974 (HSWA) to control and manage risks in the workplace. HSE regulates only health and safety; it does not develop or manage energy resources—a function controlled by the Crown Estate.⁶⁴ HSE believes that new wind-energy-specific legislation is not necessary and that it will use the existing general provisions of the HSWA to regulate both onshore and offshore sectors.⁶⁵ As reported in a position paper submitted to the committee, HSE staff consider offshore wind a “high-hazard” industry that requires management of known hazards and risks in new and challenging environments, but not a “major hazard.” According to HSE staff, industries labeled as major hazards are limited to certain sectors working with chemicals or oil and gas and require “special permitting,” such as a “safety case.”⁶⁶

In regulating offshore wind, HSE believes that identifying and considering potential hazards and associated risks early in the development process are important. The use of safe design guidelines is a better and more cost-effective option than struggling with “bolt-on safety” solu-

⁶³ Press release from AWEA: <http://www.awea.org/newsroom/pressreleases/OSHASept.cfm>.

⁶⁴ For information on the Crown Estate, see <http://www.thecrownestate.co.uk/energy/offshore-wind-energy>.

⁶⁵ See <http://www.hse.gov.uk/construction/index.htm>.

⁶⁶ Gary Lang and Rhiannon Hardy, UK HSE, paper submitted to the committee, April 2012. More information on HSE and safety cases is available at <http://www.hse.gov.uk/offshore/safetycases.htm>.

tions later in the process. HSE does not recommend or endorse a particular technology over another; it allows the adoption or adaptation of any technology as long as the developer or “dutyholder” accounts for potential risks. HSE does look to other sectors and industries for lessons learned and how these other sectors have managed risks.

As stated in the position paper, HSE staff believe that the wind industry needs to define its own health and safety culture. HSE reports that large operators and manufacturers have exhibited strong leadership in developing a regulatory framework that demonstrates safety throughout their supply chain. To this end, HSE believes that cooperation and collaboration with all stakeholders are essential aspects of building and maintaining a health and safety culture. By engaging the sector at all levels, HSE wants to encourage stakeholders to set standards and to generate guidelines. Through contacts and site visits, collaboration will also facilitate a better understanding of the wind farm life cycle and the hazard and risk profile of the wind sector.⁶⁷

In addition, the committee was informed by industry representatives that many European companies look to HSE for health and safety guidance because it has the most offshore wind turbines installed; has established clear jurisdictional lines; and has the most established set of regulations and guidelines, which are updated on the basis of experience.⁶⁸

RenewableUK

RenewableUK is the leading trade association for the wind and marine renewable industries in the United Kingdom. It promotes the generation, deployment, and use of wind, wave, and tidal power. Originally formed in 1984 as the British Wind Energy Association, RenewableUK changed its name and broadened its focus in 2004. The association became involved in offshore wind more than a decade ago and has since produced and developed a range of publications, reports, and industry guidelines. RenewableUK’s guidelines, in particular, provide important summaries of relevant health and safety issues and are drafted in

⁶⁷ Gary Lang and Rhiannon Hardy, UK HSE, paper submitted to the committee, April 2012.

⁶⁸ J. Nielsen, Siemens, presentation to the committee, April 2012.

consultation with HSE.⁶⁹ Among them are *Guidelines for Onshore and Offshore Wind Farms: Health and Safety in the Wind Energy Industry Sector* (RenewableUK 2010) and *Vessel Safety Guide: Guidance for Offshore Renewable Energy Developers* (RenewableUK 2012).⁷⁰

Occupational Health and Safety Assessment Series

Occupational Health and Safety Assessment Series (OHSAS) 18001:2007, Occupational Health and Safety Management Systems—Requirements is a recognized standard, but the International Organization for Standardization (ISO) has not adopted it. OHSAS 18001 is a specification document for developing an occupational health and safety management system and is compatible with the ISO 9001 (quality management) and ISO 14001 (environmental management) systems standards, which make integration of the management systems easier. Like ISO 9001 and ISO 14001, OHSAS 18001 is based on the plan-do-check-act management model, which is characterized by a feedback loop and continued improvement.⁷¹ The accompanying *OHSAS 18002:2008, Occupational Health and Safety Management Systems—Guidelines for the Implementation of OHSAS 18001:2007* provides guidance for implementing or improving an OHSAS 18001 SMS.

International Marine Contractors Association

The International Marine Contractors Association (IMCA) is an international association representing offshore and marine engineering companies. IMCA has two core activities, one focusing on health, safety, and the environment and the other on training and competence. These activities are divided into the four technical divisions of marine vessels, diving, offshore survey, and remote systems. Within these areas, IMCA publishes safety guidance documents, technical reports, and fact sheets for the marine contracting sector. It also collects and reports data on

⁶⁹ More information concerning RenewableUK's health and safety topics is available at <http://www.renewableuk.com/en/our-work/health-and-safety/index.cfm>.

⁷⁰ An updated Health and Safety Guideline is available at <http://www.renewableuk.com/en/publications/index.cfm/2013-03-13-hs-guidelines-offshore-wind-marine-energy>.

⁷¹ See <http://www.hse.gov.uk/foi/internalops/fod/inspect/mast/comparison.htm>.

incidents for and about its members and documents industry best practices in the areas of equipment, procedures, and personnel.

The guidance documents are available on IMCA's website; topics include personnel transfer, diving operations, lifting operations, subsea construction, and simultaneous operations.⁷² The guidance document on personnel transfer, for example, focuses on safe methods for transferring between vessels, offshore structures, and quaysides and covers such items as a risk assessment of the conditions, the training and competence of personnel, unambiguous roles and responsibilities of all involved, and clear lines of communication (IMCA 2010).

IMCA collects, analyzes, and shares data on industry incidents from work in offshore construction. One key system for distributing the data is an alert called a "safety flash." Safety flashes are developed from reports submitted to IMCA and contain descriptions of incidents, near misses, and potential hazards. The reports also give the apparent cause (or causes) of the incident and any actions taken to prevent a recurrence. Before it is distributed publicly, a safety flash is stripped of identifying information and is sent to the contributing company for its approval.⁷³

Through an annual survey, IMCA gathers additional safety information from its members. Leading and lagging performance indicators developed by the association are used. The safety performance statistics produced by IMCA allow member organizations to identify trends within the industry and to measure their performance against industry averages. According to IMCA, this continuous effort of benchmarking assists organizations in improving safety performance and reducing injury rates (IMCA 2008).

Classification Societies

Det Norske Veritas, Germanischer Lloyd, and the American Bureau of Shipping, along with other members of the International Association of Classification Societies, verify compliance with statutory regulations and recognized standards. These organizations' services include verification

⁷² For a full list of documents, see <http://www.imca-int.com/documents/publications.html>.

⁷³ A listing of the most recent safety flashes is available at <http://www.imca-int.com/documents/core/sel/safetyflash/>.

that vessels and marine structures comply with specific rules (classification) and certification that programs or systems conform to a standard. For classification, the classification society only reports whether a vessel conforms to the society's rules—whether it is “in” or “out of” class. For developing and implementing safety management programs, classification societies offer guidance documents for the marine industry that incorporate many of the following management system standards: the ISM Code, ISO 9001, ISO 14001, ISO 50001, and OHSAS 18001.⁷⁴ In addition, most classification societies provide documents on safe work design and practices, including guidance on offshore wind turbine structures,⁷⁵ ergonomics and human factors engineering, safety culture and leading indicators,⁷⁶ and the certification of management systems.⁷⁷

SUMMARY DISCUSSION

The reorganization of MMS in 2010 (see Figure 3-1) separated the previously coexisting functions of safety and environmental enforcement from those of resource development and energy management to prevent conflicts of interest. An exception to the arrangement is authority for the Offshore Renewable Energy Program, which is located in BOEM's Office of Renewable Energy. At present, BOEM will regulate worker health and safety for offshore wind farms on the OCS by requiring the submission of an SMS and will rely on another agency, BSEE, for technical expertise in the areas of safety and environmental enforcement. Although BOEM has this jurisdiction, its SMS requirements are unclear and incomplete, and they will be discussed in more detail in Chapter 5.

⁷⁴ For one example, see ABS 2012.

⁷⁵ For an example of technical requirements for offshore structures, see DNV 2011, *Design of Offshore Wind Turbine Structures*, DNV-OS-J101.

⁷⁶ Kevin McSweeney, American Bureau of Shipping, presentation to the committee, April 17, 2012. http://www.eagle.org/eagleExternalPortalWEB/ShowProperty/BEA%20Repository/Rules&Guides/Current/188_Safety/Guide; http://www.eagle.org/eagleExternalPortalWEB/ShowProperty/BEA%20Repository/Rules%26Guides/Current/86_ApplicationsofErgonomicstoMarineSystems/Pub86_ErgoMarineSystems.

⁷⁷ For examples, see <http://www.gl-group.com/en/certification/MaritimeStandards.php> and <http://www.dnvba.com/Global/certification/management-systems/Pages/default.aspx>.

The government agencies and regulations discussed earlier could help BOEM in clarifying its offshore wind farm worker health and safety management program, but most of the regulations are prescriptive in nature. Until recently, BSEE has enforced oil and gas operations by issuing PINC notices on the basis of the prescriptive regulations contained in 30 CFR 250. With the introduction of the SEMS rules in Subpart S, BSEE is moving toward a more goal-based risk management system. The elements of SEMS are discussed in Chapter 5 and could provide a more robust model for BOEM's SMS. USCG regulates health and safety for activities on the OCS involving mineral resources but not for renewable energy activities. USCG regulations, including the revised Subchapter N, could, however, inform future standards for offshore wind. BOEM's intention of regulating worker health and safety on offshore wind farms preempts OSHA's jurisdiction on the OCS according to Section 4(b)(1) of the OSH Act. However, OSHA has stated that it retains jurisdiction for wind farm projects within state waters and on the Great Lakes and that it will regulate on the basis of current health and safety rules. According to information received by the committee, neither USACE nor FERC has authority for offshore wind farm worker health and safety on the OCS, but USACE's comprehensive health and safety guidelines in its engineering manual could provide BOEM with insight for updating offshore safety standards (see Table 3-1).

HSE in the United Kingdom offers BOEM considerable guidance from its more than 10 years of regulating worker health and safety for offshore wind farms that includes collaborating with stakeholders to build and maintain a health and safety culture. Finally, BOEM could look to domestic and international standards for management models and for health and safety guidelines as it prepares to enhance its SMS. Trade associations such as AWEA, RenewableUK, and IMCA publish health and safety guidelines that often represent the best practices of their respective industries.

Chapter 4 discusses hazards associated with offshore wind farms and how regulations and standards are used to address those hazards. Chapter 5 discusses published management systems in more detail and provides examples of important SMS elements that BOEM could reference for enhancing its SMS. Chapter 6 presents the committee's key findings

and recommendations concerning the regulation of worker health and safety for wind farms on the OCS.

REFERENCES

Abbreviations

ABS	American Bureau of Shipping
ASSE	American Society of Safety Engineers
AWEA	American Wind Energy Association
BOEM	Bureau of Ocean Energy Management
BOEMRE	Bureau of Ocean Energy Management, Regulation, and Enforcement
DNV	Det Norske Veritas
DOI	U.S. Department of the Interior
IMCA	International Marine Contractors Association
NAE	National Academy of Engineering
NRC	National Research Council
OSHA	Occupational Safety and Health Administration
TRB	Transportation Research Board
USACE	U.S. Army Corps of Engineers
USCG	U.S. Coast Guard

- ABS. 2012. *Guide for Marine Health, Safety, Quality, Environmental and Energy Management (The ABS Guide for Marine Management Systems)*. Houston, Tex. <http://www.eagle.org/eagleExternalPortalWEB/ShowProperty/BEA%20Repository/References/Booklets/2012/MarineManagementSystems>.
- ASSE. 2012. ASSE Tech Brief. https://www.asse.org/shonline/docs/Z10_Tech_Brief_2012_Revised.pdf.
- AWEA. 2012. *AWEA Offshore Recommended Practices (2012): Recommended Practices for Design, Deployment, and Operation of Offshore Wind Turbines in the United States*. Washington, D.C.
- BOEM. 2011. Fact Sheet. <http://www.boem.gov/uploadedFiles/FACT%20SHEET%20BOEM.pdf>.
- BOEMRE. 2011. Fact Sheet: The BSEE and BOEM Separation: An Independent Safety, Enforcement and Oversight Mission. <http://www.bsee.gov/uploadedFiles/BOEMRE%20Reorganization%20Fact%20Sheet.pdf>.
- DNV. 2011. *Design of Offshore Wind Turbine Structures*. DNV-OS-J101. Hovik, Oslo, Norway, Sept.
- DOI. 2010a. Salazar Launches “Smart from the Start” Initiative to Speed Offshore Wind Energy Development off the Atlantic Coast. <http://www.doi.gov/news/pressreleases/>

- Salazar-Launches-Smart-from-the-Start-Initiative-to-Speed-Offshore-Wind-Energy-Development-off-the-Atlantic-Coast.cfm. Accessed March 1, 2013.
- DOI. 2010b. Secretarial Order No. 3299. <http://www.doi.gov/deepwaterhorizon/loader.cfm?csModule=security/getfile&PageID=32475>. Accessed March 1, 2013.
- DOI. 2010c. Secretarial Order No. 3302. <http://www.doi.gov/deepwaterhorizon/loader.cfm?csModule=security/getfile&PageID=35872>. Accessed March 1, 2013.
- Federal Register*. 1989. Safety and Health Program Management Guidelines; Issuance of Voluntary Guidelines. Vol. 54, No. 16, Jan. 26, pp. 3904–3916.
- Federal Register*. 2002. Inspection Under, and Enforcement of, Coast Guard Regulations for Fixed Facilities on the Outer Continental Shelf by the Minerals Management Service. Vol. 67, No. 26, Feb. 7, pp. 5912–5916.
- Federal Register*. 2011a. Oil and Gas and Sulphur Operations in the Outer Continental Shelf—Revisions to Safety and Environmental Management Systems. Vol. 76, No. 178, Sept. 14, pp. 56683–56694.
- Federal Register*. 2011b. Reorganization of Title 30: Bureaus of Safety and Environmental Enforcement and Ocean Energy Management. Vol. 76, No. 201, Oct. 18, pp. 64432–64780.
- Federal Register*. 2012. Accommodation Service Provided on Vessels Engaged in U.S. Outer Continental Shelf Activities. Vol. 77, No. 21, Feb. 1, pp. 5039–5041.
- IMCA. 2008. Safety, Environment and Legislation. <http://www.imca-int.com/documents/factsheets/IMCA-fs-SEL.pdf>.
- IMCA. 2010. *Guidance on the Transfer of Personnel to and from Offshore Vessels*. MCA SEL 025, IMCA M 202. <http://www.imca-int.com/documents/core/sel/docs/IMCASEL025.pdf>.
- NAE and NRC. 2012. *Macondo Well Deepwater Horizon Blowout: Lessons for Improving Offshore Drilling Safety*. National Academies Press, Washington, D.C. http://www.nap.edu/catalog.php?record_id=13273.
- NRC. 1990. *Alternatives for Inspecting Outer Continental Shelf Operations*. National Academy Press, Washington, D.C. http://www.nap.edu/catalog.php?record_id=1517.
- OSHA. 2010. *OSHA Authority over Vessels and Facilities on or Adjacent to U.S. Navigable Waters and the Outer Continental Shelf (OCS)*. Directive CPL 02-01-047. http://www.osha.gov/OshDoc/Directive_pdf/CPL_02-01-047.pdf.
- OSHA. 2011. CPL 02-00-151: 29 CFR Part 1910, Subpart T—Commercial Diving Operations. http://www.osha.gov/OshDoc/Directive_pdf/CPL_02-00-151.pdf.
- RenewableUK. 2010. *Guidelines for Onshore and Offshore Wind Farms: Health and Safety in the Wind Energy Industry Sector*. <http://www.renewableuk.com/en/publications/index.cfm/guidelines-for-onshore-and-offshore-wind-farms>.
- RenewableUK. 2012. *Vessel Safety Guide: Guidance for Offshore Renewable Energy Developers*. <http://www.renewableuk.com/en/publications/index.cfm/vessel-safety-guide>.

- Shaefer, L. E. 2011. Safety in Commercial Diving Practices: A Comparison of Three (3), Four (4), and Five (5) Man Dive Teams. Presented at National Offshore Safety Advisory Committee Fall Meeting, Nov. 15, Houston, Tex.
- TRB. 2012. *Special Report 309: Evaluating the Effectiveness of Offshore Safety and Environmental Management Systems*. Transportation Research Board of the National Academies, Washington, D.C. <http://www.trb.org/Publications/Blurbs/167249.aspx>.
- USACE. 2008. *Safety and Health Requirements Manual*, 2008 ed. Engineering Manual 385-1-1. Department of Defense, Washington, D.C. http://publications.usace.army.mil/publications/eng-manuals/EM_385-1-1_languages/EM_385-1-1_English_2008/toc.html.
- USCG. 2009. *U.S. Coast Guard: America's Maritime Guardian*. Coast Guard Publication 1. Washington, D.C. http://www.uscg.mil/doctrine/CGPub/Pub_1.pdf.

Regulations and Best Practices Addressing Unique Offshore Wind Farm Worker Safety and Health Hazards

The committee’s task statement (see Box 1-2) calls on it to identify “unique risks” to the health and safety of offshore wind farm workers as compared with those of workers in oil and gas operations on the outer continental shelf (OCS) and “gaps or overlaps” in jurisdictional authority. As described in Chapter 2, the oil and gas and wind industries share many offshore hazards (see Table 2-1), but the overall risk to health and safety associated with oil and gas hazards is greater than that associated with offshore wind hazards. Chapter 2 also established that offshore wind turbines share designs and characteristics with land-based turbines and that the development of offshore wind farms involves many of the same tasks and hazards as that of land-based wind farms. Despite these similarities, wind turbines require additional features and modifications for operation in a marine environment. Furthermore, the offshore environment places the technician into a larger logistical system, one in which no individual can operate independently and one that requires additional training, extra equipment, vessel coordination, weather monitoring, and emergency response capabilities—all of which create hazards and risks beyond those encountered on land.

As discussed in Chapter 3, land-based wind farms and wind farms within state territorial waters fall under the regulatory authority of the Occupational Safety and Health Administration (OSHA) or OSHA-approved state programs. OSHA regulations and standards address many of the tasks and hazards associated with wind farm development, and industry can draw on them in developing the safety management system (SMS) required by the Bureau of Ocean Energy Management

(BOEM). However, the offshore work environment presents hazards and risks not encountered in land-based development, such as personnel transfers between vessels and wind turbines, personnel transfers between helicopters and offshore structures, falls into water, and diving hazards. Furthermore, the characteristics of every offshore wind farm are slightly different—from layout to the marine conditions and environment—so optimal controls for hazards may vary accordingly. In identifying the major safety issues facing offshore wind personnel, the committee considered a broad range of possible hazards, including but not limited to the examples provided in the statement of task. Some of these examples—in particular, the use of elevators in a marine environment and the inclusion of fire suppression systems—are legitimate safety concerns that should be addressed in an SMS. However, the committee determined that they may pose less risk than originally thought; therefore, they are not discussed in as much detail as other hazards.

This chapter begins with a short list of hazards, many of which are shared by land-based and offshore wind farms. The chapter then identifies relevant federal regulations and industry standards that could apply to each hazard. The second section discusses hazards that the committee judges to be unique to offshore wind development and describes current regulations, standards, and industry best practices that offer controls for reducing risk.

HAZARDS ON WIND FARMS

Chapter 2 introduced many of the hazards that personnel confront during the wind farm life cycle. This section provides relevant regulations, standards, guidelines, or industry best practices that address or mitigate many of those hazards (see Table 4-1). The committee acknowledges that the lists of hazards and relevant regulations, standards, and guidelines are not comprehensive and that certain sections may not be applicable to offshore construction or address unique offshore operations. In addition, inclusion of regulations and standards in the table is not an endorsement or recommendation by the committee; they are presented as a resource for BOEM and industry to draw on.

TABLE 4-1 Potential Hazards on Offshore Wind Farms and Relevant Regulations

Hazard ^a	Relevant Regulations, Standards, and Best Practices ^b
Access by boat, personnel transfer, and helicopter access	<p>IMCA SEL 025, <i>Guidance on the Transfer of Personnel to and from Offshore Vessels</i></p> <p>RenewableUK, <i>Marine Safety Training Approved Training Standard</i>, Issue 1, 2012 (training standard)</p> <p>RenewableUK, <i>Guidelines for Onshore and Offshore Wind Farms: Health and Safety in the Wind Energy Industry Sector</i>, Issue 1, 2010</p> <p>RenewableUK, <i>Vessel Safety Guide: Guidance for Offshore Renewable Energy Developers</i>, April 2012</p> <p>14 CFR 27: Airworthiness Standards: Normal Category Rotorcraft</p> <p>14 CFR 29: Airworthiness Standards: Transport Category Rotorcraft</p> <p>FAA, <i>Aeronautical Information Manual: Official Guide to Basic Flight Information and ATC Procedures</i>, July 26, 2012</p>
Confined space entry	<p>ANSI/ASSE Z117.1:2009—Safety Requirements for Confined Spaces</p> <p>29 CFR 1910.146, Permit-Required Confined Spaces</p> <p>33 CFR Chapter 1, Subchapter N (included in revisions), Outer Continental Shelf Activities</p>
Crane and lifting operations	<p>API RP 2D—<i>Operation and Maintenance of Offshore Cranes</i>, 6th ed.</p> <p>API Specification 2C—<i>Offshore Pedestal-Mounted Cranes</i>, 7th ed.</p> <p>USACE EM 385-1-1, Section 16, Cranes and Hoisting Equipment</p> <p>IMCA SEL 019, <i>Guidelines for Lifting Operations</i></p> <p>46 CFR Subchapter I, Cargo and Miscellaneous Vessels</p> <p>30 CFR 250, Subpart A, Oil and Gas Operations on the OCS</p> <p>29 CFR 1926, Subpart CC, Cranes and Derricks in Construction</p> <p>HSE, United Kingdom, <i>Lifting Operations and Lifting Equipment Regulations 1998</i></p> <p>ASTM F1166-2007—<i>Standard Practice for Human Engineering Design for Marine Systems, Equipment, and Facilities</i> (Section 16.8 for design)</p>
Diving	<p>46 CFR Chapter 1, Subchapter V, Part 197, Marine Occupational Safety and Health Standards</p> <p>USACE EM 385-1-1, Section 30, Diving Operations</p> <p>ADCI (2011), <i>International Consensus Standards for Commercial Diving and Underwater Operations</i>, 6th ed.</p> <p>U.S. Navy <i>Diving Manual</i> (2008), Revision 6</p> <p>IMCA D 014, <i>IMCA International Code of Practice for Offshore Diving</i></p> <p>IMCA D 019, <i>Diving Operations in Support of Intervention on Wellheads and Subsea Facilities</i></p> <p>29 CFR 1910, Subpart T, Commercial Diving Operations</p> <p>OSHA CPL 02-00-151, 29 CFR Part 1910, Subpart T—Commercial Diving Operations</p> <p>29 CFR 1926, Subpart Y, Diving</p>

(continued on next page)

TABLE 4-1 Potential Hazards on Offshore Wind Farms and Relevant Regulations (*continued*)

Hazard ^a	Relevant Regulations, Standards, and Best Practices ^b
Electrical safety on offshore wind turbines and substations	NFPA 70E— <i>Standard for Electrical Safety in the Workplace</i> ANSI/ASSE A10.44:2006—Control of Energy Sources 33 CFR Chapter 1, Subchapter N, Part 142, Workplace Safety and Health IEC 61400-1: 2005, <i>Wind Turbines—Part 1: Design Requirements</i> 29 CFR 1910.147, Control of Hazardous Energy (Lockout/Tagout) 29 CFR 1910.269, Electric Power Generation, Transmission, and Distribution DNV-OS-J201(2009)—Offshore Substations for Wind Farms ASTM F1166-2007— <i>Standard Practice for Human Engineering Design for Marine Systems, Equipment, and Facilities</i> (Section 18.4)
Emergency evacuation or emergency egress	33 CFR 146, Emergency Evacuation Plan 29 CFR 1910.38, Emergency Action Plans 29 CFR 1917.30, Emergency Action Plans 29 CFR 1918.100, Emergency Action Plans 29 CFR 1926.35, Employee Emergency Action Plans RenewableUK, <i>Guidelines for Onshore and Offshore Wind Farms: Health and Safety in the Wind Energy Industry Sector</i> , Issue 1: 2010 ANSI/ASSE A10.26:2011—Emergency Procedures for Construction and Demolition Sites
Falls, working at heights, use of personnel lifts, rope access	ANSI/ASSE Z359—Fall Protection/Arrest ANSI/ASSE A10.32-2004—Fall Protection Systems EN 353-1:2002, Personal Protective Equipment Against Falls from a Height ASTM F1166-2007— <i>Standard Practice for Human Engineering Design for Marine Systems, Equipment, and Facilities</i> (Section 18.8) 29 CFR 1926.500, Subpart M, Fall Protection RenewableUK, <i>Lifts in Wind Turbines, Health and Safety</i> , February 2011 ASME/ANSI A17.1, Safety Code for Elevators and Escalators EN 81: Safety Rules for the Construction and Installation of Lifts
Fires in or on offshore wind turbines and substations	33 CFR Chapter 1, Subchapter N, Part 145, Fire-Fighting Equipment NFPA, Codes and Standards (e.g., NFPA 12—Standard on Carbon Dioxide Extinguishing Systems) NFPA 850: <i>RP for Fire Protection for Electric Generating Plants</i> DNV-OS-J201(2009)—Offshore Substations for Wind Farms (Section 6) Safety of Life at Sea Provisions GL <i>Wind Technical Note Certification of Fire Protection Systems for Wind Turbines</i> , Rev. 2, 2009 ed. BS EN 13565-2:2009—Fixed Firefighting Systems

TABLE 4-1 Potential Hazards on Offshore Wind Farms and Relevant Regulations (*continued*)

Hazard^a	Relevant Regulations, Standards, and Best Practices^b
Human factors health and safety issues (climbing, awkward postures, extreme environmental conditions, inadequate physical and visual access, manual material handling)	ASTM F1166-2007— <i>Standard Practice for Human Engineering Design for Marine Systems, Equipment, and Facilities</i> (multiple sections)
Human factors safety issues (pinch points, rotating equipment)	ASTM F1166-2007— <i>Standard Practice for Human Engineering Design for Marine Systems, Equipment, and Facilities</i> (Sections 14, 15, 17, 18) AWEA, <i>Recommended Practices for Design, Deployment, and Operation of Offshore Wind Turbines in the United States</i> (2012) IEC 61400-1: 2005, <i>Wind Turbines—Part 1: Design Requirements</i> BS EN 50308, <i>Wind Turbines: Protective Measures: Requirements for Design, Operation and Maintenance</i>
Slips and trips	ASTM F1166-2007— <i>Standard Practice for Human Engineering Design for Marine Systems, Equipment, and Facilities</i> (Section 11) ASTM F1637-2010— <i>Standard Practice for Safe Walking Surfaces</i> 29 CFR 1910.21-30, Subpart D, Walking–Working Surfaces ANSI A1264.1, Safety Requirements for Workplace Walking/Working Surfaces and Their Access; Workplace, Floor, Wall and Roof Openings; Stairs and Guardrails

NOTE: ADCI = Association of Diving Contractors International, Inc.; ANSI = American National Standards Institute; API = American Petroleum Institute; ASME = American Society of Mechanical Engineers; ASSE = American Society of Safety Engineers; ASTM = American Society for Testing and Materials; AWEA = American Wind Energy Association; BS = British Standard; CFR = Code of Federal Regulations; CPL = Compliance Directive; DNV = Det Norske Veritas; EN = European Norm; FAA = Federal Aviation Administration; GL = Germanischer Lloyd; HSE = Health and Safety Executive; IEC = International Electrotechnical Commission; IMCA = International Marine Contractors Association; OSHA = Occupational Safety and Health Administration; NFPA = National Fire Protection Association; RP = Recommended Practice; USACE = U.S. Army Corps of Engineers.

^aThe hazards presented are not comprehensive, but the more typical hazards, as reported to the committee, are included.

^bThe regulations, standards, and best practices presented are not necessarily comprehensive, nor are they presented in a particular order. Certain sections of these documents may not be applicable to offshore construction or address unique offshore operations. Inclusion in the table is not an endorsement or recommendation by the committee; the table is presented as a resource for BOEM and industry to draw on. Appendix B of API RP 75 lists numerous industry codes, recommended practices, and standards that may also be considered relevant.

SOURCE: Generated by the committee.

The following list provides a description of typical hazards.

- *Access by boat and personnel transfer:* Personnel must be transferred from a shoreside facility to a transfer vessel and then from the transfer vessel to the wind turbine. Boat transfers introduce hazards while embarking on or disembarking from a vessel or structure, such as tripping and falling into the water and crushing (between vessel and structure). Helicopter transfers occur as well and introduce hazards such as tripping and falling, but the transfers will occur less frequently and are more likely during emergencies. Although helicopter crashes have the potential for more fatalities, in the opinion of the committee, boat transfers will occur more often along with the possibility of more lost time injuries—incidents that lead to days away from work.
- *Confined space entry:* This hazard involves an area that is not continuously occupied and has limited means of entry and exit but that is large enough to enter and allow performance of tasks. Examples of confined spaces include the hub and blades and areas inside the monopile or foundation. Confined spaces introduce hazards such as dangerous gases, oxygen-deficient atmospheres, poor ventilation, and limited movement, in addition to the difficulty of rescuing or evacuating injured personnel.
- *Crane and lifting operations:* Large turbine components or heavy pieces of equipment must be lifted and moved. Hazards can include dropped objects, uncontrolled lifts, crushing, unbalanced vessels, crane failure, and collapse.
- *Diving:* Underwater construction and inspection require diving, which is dangerous and demanding work. Most hazards involve working underwater with tools and experiencing changes in pressure while descending from or ascending to the surface. Uncoordinated operations that lead to injuries to the diver are another hazard.
- *Electrical safety on offshore wind turbines and substations:* Working with high-voltage systems that expose personnel to electrical energy involves such hazards as electrical shocks, electrical burns, arc flashes (burns and blasts), and electrocution.

- *Emergency evacuation or emergency egress:* An incident or accident, medical emergency, fire, or sudden weather event may require immediate evacuation of personnel. Hazards from evacuations are similar to other hazards mentioned here such as falls and vessel transfers.
- *Falls, working at heights, use of personnel lifts, rope access:* Falls are one of the more common incidents in any workplace and can occur from any height. Working on a wind turbine introduces numerous potentials for falls during activities both within and outside the turbine.
- *Fires in or on offshore wind turbines and substations:* Fire in a wind turbine or substation could expose workers to burns and smoke inhalation.
- *Human factors health and safety issues (climbing, awkward postures):* Personnel climb ladders and confront prolonged kneeling and repetitive upper body movements, often in cramped spaces. These actions can lead to short-term sprains and fatigue as well as long-term injuries, particularly to backs and knees. Extreme environmental conditions (e.g., heat, cold, and noise) can also negatively affect worker health and performance. Inadequate physical and visual access in and around equipment can encourage workers to assume awkward body postures or take unsafe shortcuts to complete a task.
- *Human factors safety issues (pinch points, rotating equipment):* Personnel working around moving mechanical parts can become entangled in the machinery or face contusions, lacerations, broken bones, and amputation.
- *Slips and trips:* The marine environment introduces moving, cluttered, uneven, or slick surfaces. Vessel movement, sea state, and weather conditions can cause personnel to slip or trip, which could lead to injuries.

In the list above, the committee developed what it judges to be among the more expected, or typical, hazards of a wind farm project life cycle. Many of these hazards—such as confined space entry, crane and lifting operations, electrical injury, working at heights, fire protection, human factors safety issues, and slips and trips—are common to land-based wind farms and are addressed by federal regulations and industry consensus standards, examples of which are included in Table 4-1. The

other hazards are unique to offshore wind farms and are discussed in the next section in more detail.

HAZARDS UNIQUE TO OFFSHORE WIND FARMS

The offshore work environment presents hazards, identified in Table 4-1, that are not encountered on a land-based facility. Among them are personnel transfers, falls on the vessel or into water, diving hazards, and emergency evacuation. The following subsections discuss these hazards and identify standards and regulations that pertain to them.

Access by Boat and Personnel Transfer

Of the numerous hazards (see Table 4-1) associated with offshore wind farms, transferring personnel from a shoreside facility to the transfer vessel and then from the transfer vessel to the wind turbine poses significant risk. Throughout the life cycle of a wind farm, personnel require access to the wind turbines, and this access is provided mostly by boat. The oil and gas industry utilizes helicopters as a primary means of access to its offshore platforms. This mode of transportation is less likely to be used to access offshore wind turbines for routine operations and maintenance because of the inability to land a helicopter on a wind turbine structure and the subsequent risks associated with lowering personnel from a hovering helicopter to the nacelle of a turbine. Some wind turbines may have helicopter pads installed on top of the nacelle, although this practice is not common. Helicopter transfer, despite being an option, is not regarded as the primary means of turbine access.¹ The remainder of this subsection focuses on access by boat and the transfer of personnel.

¹ Federal Aviation Administration regulations for helicopter operations are found in 14 CFR 27: Airworthiness Standards: Normal Category Rotorcraft and in 14 CFR 29: Airworthiness Standards: Transport Category Rotorcraft. Additional information on offshore helicopter operations is found in the Federal Aviation Administration's *Aeronautical Information Manual: Official Guide to Basic Flight Information and ATC Procedures*, July 26, 2012 (http://www.faa.gov/air_traffic/publications/ATPubs/AIM/aim.pdf). Recommended practices for offshore helicopter operations are provided by the Helicopter Safety Advisory Conference and the Offshore Committee of the Helicopter Association International.

Personnel transfers are a necessary part of every visit to an offshore facility and pose routine, and potentially deadly, risks. On European wind farms, technicians are estimated to access an individual turbine at a rate of 10 to 20 “person-accesses” per year (Dalen and Jakobsson 2009),² which translates into an industry total of many potential transfers, given that Europe alone reports more than 1,660 offshore turbines installed and connected at 55 wind farms as of December 31, 2012 (EWEA 2013).

The safety of personnel transfers depends on many factors. The type of shore facility, the access site on the transfer vessel, the foundation and transition piece, and weather and sea conditions (waves, wind, and currents) influence whether safe access or egress is possible and the type of access system or vessel used. To minimize risk and maximize efficiency, any type of transfer vessel will need to nose into place easily and quickly; rest safely in position at the transfer point; and transfer personnel and equipment quickly, safely, and reliably. Above all, any personnel transfer system should maximize safety and minimize complexity.

Most of the various access systems involve a direct boat landing: the vessel docks at the turbine and maintains constant contact with the transition piece or structure by using the thrust of its engine and friction from the bow fenders. Personnel then access the turbine by a ladder on the transition piece or on a walkway between the installation vessel and the transition piece. Ladders in excess of a certain height usually have a fall arrest system. As wave height increases, such a direct landing transfer becomes less safe and can cause unsynchronized movement between the vessel and the transition piece. This type of movement introduces hazards such as personnel falling backwards onto the transfer vessel or falling into the water; consequences include injury or death by hypothermia, drowning, or crushing. Common industry controls for these hazards include wearing life jackets with personal locator beacons, wearing immersion suits, and knowing proper procedures for access and egress. Among other controls are training personnel in sea survival and testing new methods of transfer. Above all, anyone involved in the transfer operation—from vessel crew to transferee—should have the ability to

² The authors define one “person-access” as an individual crossing from a boat to an offshore wind turbine.

deem a transfer unsafe and to stop the transfer at any point. The subsections that follow discuss some other industry guidelines for transferring personnel.

Guidance from the Marine Industry

Although the International Convention for the Safety of Life at Sea (SOLAS) offers basic safety principles for pilot transfer arrangements, most guidance on the transfer of personnel is provided by industry. The International Marine Contractors Association (IMCA) offers a guidance document for the safe transfer of personnel at sea, especially transfers between vessels and between vessels and offshore structures, through a variety of methods including crew boats and offshore support vessels (IMCA 2010). The guidance document recommends that all personnel involved in the transfer understand the transfer method. The document covers the topics of risk assessment, training and competence, responsibility, and communications. The following are among the main points:

- **Risk assessment:** All personnel transfers are considered stand-alone events and require a formal risk assessment before the operation is started. Any risk assessment should consider such issues as the necessity and frequency of the transfers, environmental conditions (weather, wind speed, wave height, etc.), types of vessels used, availability of personal protective equipment, simultaneous operations, and qualifications of the personnel involved. If issues or conditions change during an operation, proper management of change procedures should be in place to track concerns of risk.
- **Training and competence:** All personnel involved in the transfer should be competent and should have appropriate training. The personnel should understand the process and be able to explain the steps involved.
- **Responsibility:** The roles and responsibilities of all personnel, especially those supervising the process, should be clearly defined. IMCA considers the vessel master or the offshore structure manager to be responsible for the safe transfer of personnel. The final decision whether to transfer remains with the vessel or structure supervisor.

- **Communications:** All personnel involved in the transfer should establish communication (both radio and visual) before the operation and maintain and verify communications throughout the process.

The guidance document also discusses personnel transfers using small boats, larger crew boats, transfer baskets, and gangways or walkways (including hydraulic gangways). Although industry is beginning to rely on newer technology (discussed below) to conduct personnel transfers, the focus of this section is on transfers using larger crew boats. Crew boats should be seaworthy and appropriate for the sea and weather conditions. Crew boat personnel should be competent and should have received appropriate training; more important, they should be able to show this competency. Before the start of the voyage, all participants should be briefed on proper emergency procedures and available emergency equipment. Crew boats should have sufficient numbers of life vests and rafts, and personnel should know their location as well as the location of fire-fighting equipment and escape routes. In addition, any equipment transfers should be treated as separate operations, and equipment should be transferred separately from personnel.

RenewableUK Guidelines and Standards

The United Kingdom leads the world in offshore wind farm development (EWEA 2013) and leads in the development of worker health and safety practices. The trade association RenewableUK publishes multiple documents on a range of health and safety topics to guide industry by sharing best practices and lessons learned. *Guidelines for Onshore and Offshore Wind Farms* (RenewableUK 2010) summarizes current guidance on health and safety concerns arising during the life cycle of onshore and offshore wind farms and describes the most important issues relevant to industry health and safety. The guidelines cover topics similar to those addressed by the IMCA guidance document (discussed above), such as risk assessment and management of change, competence and training of personnel, and communication, but they go into more detail in discussing site access and egress during each phase. While the document does not address all possible health and safety risks during a wind project's life cycle, it does recommend that appropriate policies and procedures for transferring personnel and equipment be developed

and implemented and that a thorough risk assessment be conducted. In addition, Appendix 1 of the *Guidelines for Onshore and Offshore Wind Farms* recommends specific best practices on access, egress, and emergency response for offshore turbines. The recommendations do not constitute a definitive list and are based on the experience of wind farm operators in the United Kingdom. The following is a partial list of recommended requirements for ladder access and egress:

- Optimally positioned ladders to take advantage of sea state,
- Placement of rest platforms on transition pieces if ladders exceed a certain length,
- Installation of two fenders to protect the ladder during boat landing,
- Inclusion of lifting equipment (davit or winch) for tools and other equipment,
- Installation of fall arrest systems if ladders exceed a certain length,
- Inspection of equipment (lifting, emergency, and fall arrest) at least biannually, and
- Compatibility between ladder docking configurations and service vessels.

The requirements also indicate that all personnel should be trained and demonstrate competency in ladder access to and egress from a vessel and in the use of appropriate personal protective equipment and sea survival techniques. More important, the guidelines note that risk assessments should account for advances in the industry's knowledge of operations and for new technology and changes in state-of-the-art equipment and that any recommended best practices should evolve as well.

When appropriate, RenewableUK has supplemented its guidelines document with a minimum recommended safety training standard for personnel in the areas of marine safety and vessel transfer, working at heights, and rescue. The standard details the process and methods for assessing and certifying the competency of all personnel involved in vessel transfer (RenewableUK 2012a).³ Although it does not address

³ The Global Wind Organisation released a similar basic training standard in an effort to document common industry best practices (see GWO 2012).

every health and safety issue associated with vessel transfers and is directed at UK health and safety law, the standard offers a common approach for providers of basic training and competency development. RenewableUK has also developed a document for guiding developers in the offshore renewable energy industry through the health and safety concerns related to selecting and managing commonly used vessels (RenewableUK 2012b).

Evolving Access Technology

Sea state and weather conditions are determining factors for transit and transfers at sea. With an increasing number of offshore turbines planned farther out at sea, industry is attempting to extend the weather window for serving turbines. For European operations, mainly in the North Sea, commonly used technology allows safe transfers with significant wave heights up to 1.5 meters, for an average window of 210 days per year. If safe, efficient, and cost-effective transfers could occur in significant wave heights up to 3.0 meters, the serviceable weather window could increase to 310 days per year.⁴ Industry is therefore using newer technology, such as hydraulically managed equipment, to counter the effects of increased wave height and compensate for wave motion. Two examples of this type of technology shown to the committee include the Ampelmann system and the MaXccess system.⁵ Other organizations are also encouraging new technology in providing solutions for safer turbine access and reduced costs.

The Carbon Trust is an independent organization working with the private and public sectors to research and promote energy-saving technologies to reduce costs. Its offshore wind accelerator (OWA) research and development program has focused on five areas with the greatest potential for reducing the total cost of constructing, operating, and

⁴ B. Gellatly, presentation at the Offshore Energy Knowledge Exchange Workshop, Washington, D.C., April 11, 2012. http://www.wind.energy.gov/pdfs/offshore_energy_knowledge_exchange_workshop_report.pdf.

⁵ More information on these systems is available at <http://www.ampelmann.nl/> and <http://www.osbitpower.com/maxaccess.html>.

financing large offshore wind farms, one of which is improved turbine access systems for technicians and equipment in heavier seas.

The OWA access competition seeks to identify and develop new access systems that increase the weather window for turbine availability and the safety of those being transferred. The competition has selected designs in three categories: vessels, transfer systems, and launch and recovery systems.

Some of the six vessel designs chosen in this category include transfer system designs: the TranSPAR craft, the Windserver, the Nauti-Craft, and the Pivoting Deck Vessel. These four designs would transfer personnel and equipment from vessel to turbine with potential motion compensation technology and include the Autobrow, the BMT and Houlder Turbine Access System Mark II, the Momac Offshore Transfer System, and the Wind Bridge. The launch and recovery systems include designs from three companies and establish bases or mother ships for dispatching and recovering craft from sea.⁶ Each of these designs offers the potential for reducing risk in transferring personnel between vessels and turbines, although each design is likely to have its own strengths and weaknesses. Because site conditions and equipment at offshore wind farms can vary, attempting to mandate one design over another might be difficult.

Summary

The committee is unaware of any U.S. regulations directly addressing access by boat or the transfer of personnel between a vessel and an offshore structure. While SOLAS offers basic safety principles for pilot transfer, most guidance on the transfer of personnel is provided by industry best practices or by guidelines from groups such as IMCA and RenewableUK. Technology in this area is evolving rapidly, and development of U.S. regulations or standards could be difficult. The transfer of personnel, therefore, could benefit from a performance-based rather than a prescriptive approach.

⁶ More information concerning each of these designs is available at <http://www.carbontrust.com/media/105302/owa-access-bg-29may2012.pdf>.

Commercial Diving Operations

Commercial diving is dangerous and physically demanding work that can occur during underwater construction, welding, inspections, and repairs of a variety of structures such as offshore oil and gas rigs, bridges, piers, and ships. The hazards of diving operations for offshore wind farms occur during various phases such as foundation installation, cable laying, and regular foundation inspections. During its information-gathering period, the committee was given to understand that remotely operated vehicles may be used in the future, especially for cable laying, but that commercial divers will be used for many tasks in shallow water.⁷ Divers face numerous health and safety hazards related to the diving itself and to working in an underwater environment with tools or machinery: experiencing changes in pressure during descents to the seabed or ascents to the surface, wearing bulky and complex equipment, and being submerged for potentially long periods of time. Divers must contend with specific site conditions, such as tides and other seabed hazards, and with working in low light or in an artificial light environment. In addition, commercial divers must often work with heavy tools or machinery. The work requires experienced and well-trained people. All diving operations should be well planned and managed carefully throughout. The next subsection reviews the most relevant federal diving regulations that would apply to wind farm operations on the OCS.

Commercial Diving and Federal Regulations

Commercial diving operations from vessels and facilities that are inspected by the United States Coast Guard (USCG) are subject to the regulations contained in 46 CFR Chapter I, Subchapter V, Part 197, Subpart B. Although these regulations are undergoing revision at the time of this report, Part 197 would apply to diving operations for offshore wind farms. The regulations require assignment of roles and responsibilities

⁷ J. Nielsen, Siemens, presentation to the committee, April 2012.

for the vessel or facility, including designation of a person in charge (if not the vessel or facility master). Before each diving operation, the name of a diving supervisor is designated and provided to the person in charge. The diving supervisor is responsible for the health and safety of all diving personnel during an operation and must comply with all parts of the regulations. Subpart B (§§197.300 to 197.346) sets forth requirements for diving equipment and for first aid and medical treatment equipment. The responsibilities of the person in charge and of the diving supervisor are elaborated in §197.402 and in §197.404, respectively. The regulations require that the diving supervisor brief the diving team on relevant information about the operation including proper procedures, unusual hazards, and environmental conditions.

All diving procedures are contained in the operations manual, which is prepared by the diving supervisor and provided to the person in charge before an operation. The operations manual explains the roles and responsibilities of dive team members, provides procedures and checklists for all safety and diving equipment used for specific diving modes, and discusses emergency procedures for potential scenarios (see §197.420). The diving supervisor is required to inspect and test all diving equipment on a periodic basis and especially before a diving operation. The diving supervisor, overseen by the person in charge, is also required to maintain entries about every commercial diving operation in a logbook (required information is located in §197.482).

OSHA has regulations for commercial diving under 29 CFR 1910, Subpart T (general industry standards) and under 29 CFR 1926, Subpart Y (construction standards). Additional guidance from a recently published compliance directive (OSHA 2011) provides instruction for OSHA offices in establishing intervention and inspection programs and information for industry in ensuring compliance with diving standards. The OSHA commercial diving rules have not been revised recently and, in the opinion of the committee, are widely acknowledged to be out of date. The regulations in 29 CFR 1910 include requirements for diver experience and operational procedures and would apply to wind farm operations occurring within state waters. Minimum training requirements and the condition that assignments be based on a diver's experi-

ence are set forth in §1910.410. All dive teams require a person in charge with appropriate experience and training. A manual that contains the roles and responsibilities of the diving team and that describes the safety practices, equipment, and emergency procedures for all diving operations must be developed and maintained.

Pre-dive procedures (§1910.421) should include an assessment of all the health and safety elements that occur during an operation, such as the proper number of team members for the dive, the diving mode and equipment used, dive site conditions, and emergency procedures. The regulations require inspection of all equipment and the briefing of team members on topics such as dive tasks, appropriate safety procedures for the operation, and hazards associated with the dive. Appropriate procedures during the dive operation are listed in §1910.422. Entry into and exit from the water, communications, and the use of any power tools or equipment are included. Requirements for post-dive procedures and decompression are provided in §1910.423, proper equipment procedures are listed in §1910.430, and record keeping requirements are given in §1910.440.

Other federal diving regulations include those of the U.S. Department of the Navy (USDON) and the U.S. Army Corps of Engineers (USACE). USDON publishes a comprehensive diving manual for naval personnel and the Navy's permanent civilian employees. The Navy's manual provides detailed diving requirements and procedures that are at least equivalent to the regulations in USCG's 46 CFR 197 and in OSHA's 29 CFR 1910, Subpart T, and could provide useful guidance. One example is the planning and operational risk management (ORM) process discussion in Chapter 6 (U.S. Navy 2008), which provides techniques for managing the risks of diving operations. The five-step ORM process first identifies the hazards associated with a task and then determines the risk of the hazards, calculates and ranks the risks, implements controls to reduce or eliminate risks, and evaluates the controls to ensure that they have the desired effect. This process allows for corrective action and improvement if an implemented control does not work. USACE also has diving requirements in Section 30 of its Engineering Manual (EM) 385-1-1. The requirements are mandatory for all Department of Defense construction contracts

and contractors conducting business with USACE and include such items as a safe practices manual, a dive operations plan, an activity hazard analysis, an emergency management plan, and minimum personnel qualifications (USACE 2008). A revision of the EM 385-1-1 safety manual is expected in 2013.

Industry Guidance and Commercial Diving Operations

The Association of Diving Contractors International, Inc. (ADCI), has developed consensus standards that represent industry best practices for all types of underwater work for commercial diving operations (see ADCI 2011). Section 2 of the document lists minimum qualifications and medical and training requirements for personnel seeking work in commercial diving. The Commercial Diver Certification Program in Section 3 ensures that personnel have met uniform minimum duties and responsibilities with respect to a particular job category and have obtained a certification card that reflects their qualifications and competency. Personnel holding a valid ADCI commercial diver certification card are considered to be in compliance with the training requirements listed under 29 CFR 1910.410 (OSHA 2011). OSHA has stated that the contents of the ADCI consensus “document meet or exceed the requirements of 29 CFR Part 1910, Subpart T,” and for diving issues that OSHA regulations do not address, “OSHA recognizes ADCI standards as the best established industry practice” (OSHA 2011, A-3). USCG also recognizes the ADCI standards as meeting or exceeding its regulations for commercial diving operations under 46 CFR 197.

The remaining sections of the ADCI standards provide a broad list of requirements for commercial diving operations. For example, Section 4 defines the various diving modes and sets forth minimum personnel and equipment requirements and operational guidelines for each mode. Operational procedures and guidelines for the safe practices manual, project plans, logbooks, job hazard analysis, and dive team brief are discussed in Section 5; emergency procedures and accident reporting are discussed in Section 7.

IMCA provides another code of good practice for diving operations (IMCA 2007). Like the ADCI document, the IMCA code discusses and

defines the roles and responsibilities of personnel involved in the diving operation, the types and suitability of equipment for the operation, the necessary qualifications and training of personnel, the requirement of a project plan and risk management process, and the need for emergency plans. Diving logbooks, checklists, incident reporting procedures, and management of change procedures are all cited in the documentation and auditing of diving operations. Similarly, RenewableUK's *Guidelines for Onshore and Offshore Wind Farms* discusses the importance of planning and management during diving operations. Section 9.14.6 of the guidelines lists considerations that the diving project plan should include in a risk assessment (RenewableUK 2010).

Summary

Of the many hazards of wind farm development, diving operations are unique to offshore wind farms. Multiple agencies promulgate federal diving regulations, including USCG, OSHA, USDON, and USACE, but diving operations for offshore wind farms would need to comply with the USCG regulations in 46 CFR 197. The federal rulemaking process can be long and arduous, which is why USCG's forthcoming revisions of diving regulations have taken several years. Although consensus standards can also take a long time to develop, industry standards are updated—often a requirement—on a more regular basis and provide a good understanding of the industry's knowledge base and best practices. For this reason, federal regulations have often lagged behind consensus standards, prompting both USCG and OSHA, in the case of diving, to reference the ADCI consensus standard as meeting or exceeding their requirements. The ADCI standards could therefore provide a valuable resource to industry in developing BOEM's required SMS.

Emergency Evacuation

The need for rapid and safe evacuation of personnel from potential or actual hazards is common to many work environments. Emergency evacuations occur in response to an incident or accident, a medical emergency, a fire, or a sudden weather event such as lightning. Procedures

for emergency evacuations and measures for addressing emergency scenarios for all personnel and all tasks undertaken during a project life cycle are often documented in frameworks called emergency response plans, and as described in Chapter 5, general requirements for emergency response plans are given in many SMS standards. The following subsection reviews evacuation plans available in federal regulations; however, the required elements for the plans differ by source and may not be relevant to offshore wind farms. The second subsection below discusses evacuation plans originating from the offshore wind industry.

Federal Regulations and Emergency Plans

In 33 CFR 146.140, USCG requires the operator of each manned facility on the OCS to develop an emergency evacuation plan (EEP). The EEP may apply to multiple facilities if the facilities are near each other. At a minimum, the EEP must have a record of change, a list of important contacts and primary responsibilities, a list of available communication and weather forecasting equipment, a description of events requiring evacuations, and a list of means and procedures for implementing the evacuations. USCG must approve the EEP and must reapprove it when substantive changes are made. Emergency evacuation drills corresponding to the EEP should occur on a regular basis and must be documented in a logbook. The EEP is for manned facilities and may not apply to offshore wind farms, although it could provide a template for future plans if offshore substations are manned or have emergency accommodations.

OSHA's emergency action plan (EAP), mandated by 29 CFR 1910.38, requires procedures for reporting emergencies and assigning evacuation routes, for accounting for employees after the evacuation, and for performing rescue and medical functions. A listing of employees who may need information about the EAP is necessary. The EAP also requires maintenance of an alarm system with a distinct signal and the training of employees in assisting in the safe and orderly evacuation of others. Employers must review the EAP with each employee covered by the plan. The regulations in 29 CFR 1917.30, 29 CFR 1918.100, and 29 CFR 1926.35 set forth elements that should be included in an EAP,

such as emergency escape routes and escape procedures, documented roles and responsibilities of personnel, an appropriate alarm system, and training.

Industry Guidance and Emergency Evacuation

In its *Guidelines for Onshore and Offshore Wind Farms*, RenewableUK recommends developing an emergency response plan (ERP) addressing all emergency situations that may occur during the wind farm development process. However, all offshore renewable energy developers and operators in the United Kingdom are required to formulate ERPs by using the Maritime and Coastguard Agency's (MCA's) emergency response cooperation plan (ERCoP) template⁸ and must submit their plans to MCA for approval before construction can begin. On the basis of the MCA template, Section 9.10 of RenewableUK's guidelines discusses items and procedures recommended for inclusion in the ERP and develops "bridging" documents to the ERPs of any contractors (RenewableUK 2010).

Early in the development of an ERP, operators must consider the distance from the offshore renewable energy site to emergency services and must assess the level of training needed by on-site personnel in carrying out the plan. Once ERP development is under way, all site plans and access points must be documented, and information must include the contact details of all personnel and vessels and the procedures for emergency communications. The roles and responsibilities of key personnel managing the ERPs must also be documented. Details must include all potential hazards and emergency situations encountered, with documented procedures based on appropriate risk assessments. More detailed response procedures are required for events such as evacuations from the turbine, fires, falls into the water, and extreme sea or weather conditions. If emergency supplies and accommodations

⁸ MCA implements maritime safety policy in the United Kingdom. The MCA ERCoP template includes requirements for emergency response on offshore renewable energy installations and search and rescue helicopter operations. More information concerning the MCA template is available at http://www.dft.gov.uk/mca/mcga07-home/shipsandcargoes/mcga-shipsregsandguidance/mcga-windfarms/offshore-renewable_energy_installations/dops_-_all-newpage-26.htm.

are not provided in individual turbines, details and locations of nearby facilities that can provide assistance must be documented and weather monitoring capabilities provided.

To ensure that all personnel are familiar with the ERP, regular training exercises are recommended. Personnel should understand emergency response arrangements and the chain of command during emergency situations. Their skill levels and competence are increased through safety drills, offshore survival training, and informational exchanges in which personnel are encouraged to discuss their views on health and safety. Personnel must understand the operational limits of vessels and equipment, and clear boundaries must be established for work stoppage during bad weather. If personnel are at risk of being stranded overnight, arrangements should include sleeping accommodations, equipment, and survival rations. As mentioned above, Appendix 1 of the guidelines provides additional detail concerning emergency egress procedures and emergency accommodations on offshore turbines and other structures. It contains flowcharts that provide recommended procedures for emergency situations such as accidents in the wind turbine or personnel stranded offshore by weather conditions. The flowcharts are only intended to provide a generic framework for addressing emergency situations but are adaptable to project- or site-specific scenarios.

Summary

Emergency response and prevention plans are a required element in most SMS standards. USCG requires the submission of an EEP for all manned facilities on the OCS, and OSHA requires employers to submit an EAP. Elements of both emergency plans could provide a resource for industry SMSs as required by BOEM and apply to offshore wind farms.

Whether operators of offshore wind farms will be required to follow USCG regulations is unclear, since offshore turbines are unmanned. RenewableUK offers a more detailed ERP guideline—based on MCA’s emergency response template—that must address all emergency situations that could occur during the wind farm development life cycle.

SUMMARY DISCUSSION

This chapter reviews the more common hazards associated with wind farm development and identifies relevant federal regulations and industry standards that may apply to each. The chapter explains three hazards that are unique to offshore wind development: personnel transfers, diving operations, and emergency evacuations. The committee was not in a position to catalog all relevant documents that might apply and acknowledges that the inventory is not comprehensive. Instead, the committee listed some of the applicable regulations and recognized best practices in health and safety that exist in the United States and internationally as resources for BOEM and industry to draw on. Although the chapter cites many relevant federal regulations and industry standards, the committee was unable to judge their efficacy. Such a task would require an in-depth review of each and time and resources far exceeding those available to the committee. In developing and applying its SMS regulation, the committee expects that BOEM will require industry to follow existing consensus standards and best practices as they are revised.

Unlike personnel transfers in the oil and gas industry, which rely heavily on helicopters, those for offshore wind facilities will occur more often by boat. The wind industry has shown an ability to develop and adopt new technologies for turbine access and transfers that can help to reduce risk and update best practices. USCG and OSHA have regulations that address diving hazards, but industry associations provide useful standards as well. Both OSHA and USCG acknowledge that the industry's diving standards (those of ADCI), for the most part, meet or exceed applicable federal regulations. EEPs are a required SMS element, and both USCG and OSHA mandate plans for various industries, but elements from the federal regulations are for manned facilities and may not be relevant to offshore wind farms. RenewableUK's guidelines document includes information on emergency evacuations pertaining to wind farms and is a good resource for industry. Although consensus standards take time to develop and therefore often lag behind the collective knowledge base of an industry, the standards and industry best practices—as in the case of diving standards—may often be more

up to date and better reflect the knowledge of industry than do federal regulations. Chapter 5 discusses published management systems in more detail and provides examples of important SMS elements that BOEM could reference in enhancing its SMS and in providing guidance to industry.

REFERENCES

Abbreviations

ADCI	Association of Diving Contractors International, Inc.
EWEA	European Wind Energy Association
GWO	Global Wind Organisation
IMCA	International Marine Contractors Association
OSHA	Occupational Safety and Health Administration
USACE	U.S. Army Corps of Engineers

- ADCI. 2011. *International Consensus Standards for Commercial Diving and Underwater Operations*, 6th ed. Houston, Tex.
- Dalen, G., and M. Jakobsson. 2009. Access to Offshore Windfarms. In *Offshore Wind Power* (J. Twidell and G. Gaudiosi, eds.), Multi-Science Publishing Co. Ltd., Brentwood, United Kingdom.
- EWEA. 2013. The European Offshore Wind Industry: Key Trends and Statistics 2012. http://www.ewea.org/fileadmin/files/library/publications/statistics/European_offshore_statistics_2012. Jan. Accessed Feb. 7, 2013.
- GWO. 2012. *Global Wind Organisation Standard: Basic Safety Training (Onshore/Offshore)*. <http://www.ewea.org/policy-issues/health-and-safety/gwo-standards/>.
- IMCA. 2007. *IMCA International Code of Practice for Offshore Diving*. IMCA D 014, Rev. 1. <http://www.imca-int.com/documents/divisions/diving/docs/IMCAD014.pdf>.
- IMCA. 2010. *Guidance on the Transfer of Personnel to and from Offshore Vessels*. IMCA SEL 025, IMCA M 202. <http://www.imca-int.com/documents/core/sel/docs/IMCASEL025.pdf>.
- OSHA. 2011. *29 CFR Part 1910, Subpart T—Commercial Diving Operations*. Directive CPL 02-00-151. http://www.osha.gov/OshDoc/Directive_pdf/CPL_02-00-151.pdf.
- RenewableUK. 2010. *Guidelines for Onshore and Offshore Wind Farms: Health and Safety in the Wind Energy Industry Sector*. <http://www.renewableuk.com/en/publications/index.cfm/guidelines-for-onshore-and-offshore-wind-farms>.
- RenewableUK. 2012a. *Approved Training Standard, Marine Safety Training (MST)—Vessel Transit and Transfer Standard, Issue 1: 2012*. <http://www.renewableuk.com/download.cfm?docid=55C54586-393C-4239-9A1388D1EDD5894E>.

RenewableUK. 2012b. *Vessel Safety Guide: Guidance for Offshore Renewable Energy Developers*. <http://www.renewableuk.com/en/publications/index.cfm/vessel-safety-guide>.

USACE. 2008. *Safety and Health Requirements Manual*, 2008 ed. Engineering Manual 385-1-1. Department of Defense, Washington, D.C. http://publications.usace.army.mil/publications/eng-manuals/EM_385-1-1_languages/EM_385-1-1_English_2008/toc.html.

US Navy. 2008. *U.S. Navy Diving Manual*, Volumes 1–5, Revision 6. Naval Sea Systems Command, Washington, D.C. http://www.supsalv.org/00c3_publications.asp?destPage=00c3&pageId=3.9.

Enhancing Health and Safety Through Safety Management Systems and Design

The oil and gas industry has operated on the U.S. outer continental shelf (OCS) for decades, but the U.S. offshore wind industry is only now becoming established. At the time of this writing, offshore wind projects have received preliminary approvals from relevant federal agencies, but construction has not yet started. As mentioned in Chapter 3, the Bureau of Ocean Energy Management (BOEM) issued basic requirements for a safety management system (SMS) in Subpart H of 30 CFR 585 in 2009 but has not fully defined the substance to be included in an SMS. Chapter 4 identified many hazards shared by land-based and offshore wind farms and relevant federal regulations and industry standards that may apply, and it discussed several hazards unique to offshore wind farms.

Chapter 5 examines the U.S. Department of the Interior's current regulatory frameworks for offshore worker health and safety and presents other SMS models that could guide BOEM in developing its requirements and standards. The chapter discusses factors that shape and support the SMS, including the role of organizational culture in achieving the health and safety goals of an organization, the importance of performance indicators and monitoring for continued safe operations, the necessity of inspection and audits as important tools for both the regulator and operator, and the value of training. Finally, the role of design in providing the best foundation for safe operations and as a key component of a continuous improvement process for future models as part of the SMS is introduced.

SAFETY MANAGEMENT SYSTEMS

In general, a management system is a structured approach that an organization uses to accomplish its goals or objectives. The approach identifies hazards, manages risk through various tools and actions,

and reflects the organization's policies and processes in reaching its goals. A management system includes a process by which managers assess the outcomes of implemented programs and policies and take corrective action as needed. This cycle contributes to a continual improvement in organizational performance. The broad intent of a management system for occupational health and safety is to define an organization's health and safety policies and the responsibilities of key personnel, to identify hazards that can lead to incidents, to determine the risk associated with each hazard, and to take appropriate precautions to decrease the likelihood of incidents and mitigate those that occur. An SMS can provide the framework for an effective safety culture, which is necessary in implementing the organization's safety goals. The SMS must also provide a mechanism allowing managers to verify that the health and safety policies and procedures produce the intended results and to take any necessary corrective action. Such a safety improvement cycle (such as the "plan-do-check-act" process) places the responsibility for safe operations on the organization through measures of accountability. One of the challenges in implementing an SMS-based continuous improvement process in offshore wind farms is the relatively brief construction employment peak, which involves multiple employers, followed by intermittent maintenance. Communication and coordination of multiple concurrent SMSs in a congested work space must be clearly addressed in lease documents, bid submissions, contracts, individual employer SMSs, and perhaps regulations.

BOEM's SMS REGULATIONS

This section characterizes the committee's understanding of BOEM's current SMS requirement before introducing important SMS concepts from other sources. As discussed in Chapter 3, the regulations in 30 CFR 585.810 state that the lessee must submit a description of the SMS along with the construction and operations plan (COP), site assessment plan (SAP), or general activities plan (GAP). The lessee must ensure that the SMS is fully functional before beginning any activities described in the COP, SAP, or GAP, but the lessee is not required to submit its SMS to BOEM for the agency's review.

The regulations state that the SMS description must include the following:

- (a) How you will ensure the safety of personnel or anyone on or near your facilities;
- (b) Remote monitoring, control, and shut down capabilities;
- (c) Emergency response procedures;
- (d) Fire suppression equipment, if needed;
- (e) How and when you will test your SMS; and
- (f) How you will ensure personnel who operate your facilities are properly trained.

This rule requires lessees to implement a risk-specific performance-based SMS; however, the lack of detail or specific guidance also may mean that an industry's SMS does not have the rigor or detail that is warranted. The rule does not provide lessees with much detail or guidance and does not necessarily encourage or support technical health and safety understanding, and therefore capability, within the company or at the work site. The committee recognizes that the elements set forth in 30 CFR 585.810 do not represent the final detailed SMS requirement, but the current version falls short in several ways. First, it does not include many elements recognized as necessary for an SMS. Furthermore, BOEM does not explain what a "description" of the SMS is, what should be included in the description, and how the description of the SMS differs from a fully functioning SMS. Finally, some of the hazards, in the committee's opinion, appear more relevant to oil and gas operations than to wind farms. Wind turbines are unmanned structures and pose less risk to worker health and safety than do manned offshore oil and gas platforms. For example, mandated fire suppression—such as carbon dioxide systems—may be appropriate for offshore electrical support platforms but may be an excessive requirement for individual wind turbines. As reported to the committee, fire is a hazard in both an offshore wind turbine and an offshore substation. But a fire occurring on a wind turbine is an isolated event and usually will not pose a danger to the people and structures around it. At the request of an operator, turbine or third-party vendors will install fire prevention systems that sense and suppress fire in various areas of the turbine, but the decision is usually based on risk assessment.

IMPORTANT ELEMENTS FOR SMSs

This section introduces important elements that are included in published SMS standards and in other reports. The committee believes that these documents can provide guidance for the SMS requirements described in §585.810 and for additional elements that the committee believes are optimal for any SMS. In assessing the adequacy of BOEM's current SMS requirements, the committee reviewed relevant reports and published SMS standards and guidelines. The review was not exhaustive but included documents often cited by various industries for developing management systems.

The documents reviewed include the following:

1. American Petroleum Institute (API) Recommended Practice (RP) 75, *Recommended Practice for Development of a Safety and Environmental Management Program for Offshore Operations and Facilities*, 3rd ed., May 2004;
2. International Maritime Organization (IMO), *ISM Code and Guidelines*, 2010 ed.;
3. International Labour Organization, OSH 2001, *Guidelines on Occupational Safety and Health Management Systems*, 2001;
4. American National Standards Institute (ANSI) Z10-2012, *Occupational Safety and Health Management Systems*, American Industrial Hygiene Association, 2012;
5. Occupational Health and Safety Assessment Series (OHSAS) 18001: 2007, *Occupational Health and Safety Management Systems—Requirements*, July 2007;
6. Minerals Management Service Technology Assessment and Research (TA&R) Project 633, *Template for a Safety Management System for Offshore Wind Farms on the OCS*, October 2009;
7. *Cape Wind Project Safety Management System*, Rev. B1, October 2010;
8. The Occupational Safety and Health Administration's (OSHA's) *Process Safety Management* (see 29 CFR 1910.119);
9. OSHA's *Safety and Health Program Management Guidelines* (see *Federal Register*, Vol. 54, pp. 3904–3916, January 26, 1989); and
10. Bureau of Safety and Environmental Enforcement (BSEE) TA&R Project 709, *Sample Safety Management System, Draft*, Version 1.

The outline that follows contains common elements from many of these documents and, in the opinion of the committee, offers a base list of concepts needed for any SMS as mandated by 30 CFR 585.810.

1. Safety policy and organization

- a. Policy for ensuring worker health and safety (OHSAS 18001-4.2; ANSI Z10-3.1.2)

Outline key principals and objectives to which the organization is committed, including protection of worker health and safety, compliance with applicable laws, worker participation, and continual improvement.

- b. Authority and responsibilities for key positions (OHSAS 18001-4.4.1; ANSI Z10-3.1.3)

Develop an organization chart that identifies the key positions necessary for implementation of the SMS and defines their authority and responsibilities.

- c. Personnel qualifications, training, competency (OHSAS 18001-4.4.2; ANSI Z10-5.2)

Identify qualifications necessary for personnel in carrying out the various SMS activities, what training will be provided, and how competency of the personnel will be evaluated and documented.

- d. Management commitment and employee participation (OHSAS 18001-4.4.1, 4.4.3.2; ANSI Z10-3.1.3, 3.2)

Provide sufficient resources to implement the SMS and ensure that employees have the time and resources to participate in all aspects of the SMS, including hazard identification, program evaluation, and corrective actions.

2. Planning

- a. Hazards analysis (OHSAS 18001-4.3.1; ANSI Z10-5.1.1; API RP 75 Section 3)

A systematic process to identify hazards to health and safety during all phases of the project (from design to decommissioning) and assess the risks associated with those hazards. This analysis occurs initially during design and may be repeated in whole or in part during program updates.

- (1) Construction hazards including assembly yard and load-out-activities

- (2) Operational hazards including electric service platform activities
- (3) Decommissioning hazards including subsea cable activities
- b. Health and safety hazard mitigation, hierarchy of hazard controls (OHSAS 18001-4.3.1; ANSI Z10-5.1.2)
 - Define the process by which hazards identified can be managed through a hierarchy of controls.*
 - (1) Design approaches to eliminate or mitigate hazards
 - (2) Human factors engineering (HFE) to eliminate or mitigate hazards
 - (3) Hierarchy of controls
 - i. Elimination
 - ii. Substitution
 - iii. Engineering controls
 - iv. Warnings, administrative controls
 - v. Personal protective equipment
- c. Operating procedures [API RP 75 Section 5; IMO International Safety Management (ISM) 7]
 - Establish procedures, plans, and instructions for key operations concerning the safety of the personnel and addressing human factors issues.*
 - (1) Permit to work
 - (2) Security
 - (3) Simultaneous operations
 - (4) Marine operations
 - (5) Safe work practices, written health and safety programs
 - (6) Job safety analysis, detailed steps of health and safety program
 - (7) Health and fitness for duty
 - (8) Site safety, first aid
- d. Management of change (OHSAS 18001 4.3.1; ANSI Z10 5.1.3; API RP 75 Section 4; Process Safety 1910.1191)
 - Establish processes to handle changes to the operations, personnel, and facilities so that hazards are identified and mitigated and the SMS is updated.*
- e. Emergency preparedness, prevention, response (OHSAS 18001 4.4.7; ANSI Z10 5.1.6)

Define potential emergency situations relevant to various operations, how to respond to those emergencies to protect health and safety, and how to test and drill the response plans.

- f. Quality assurance, mechanical integrity, maintenance (API RP 75 Section 8; IMO ISM Section 10)

Establish procedures identifying critical equipment and ensuring that it is designed, fabricated, installed, inspected, and maintained in an appropriate manner to provide for safe operations.

- g. Commissioning (API RP 75 Section 9)

Establish procedures to define a safety review to take place during or before commissioning of new or modified facilities.

3. Implementation

- a. Communication (OHSAS 18001 4.4.3.1; ANSI Z10 5.3)

Ensure that the SMS and its implementation are communicated to all levels of the organization and other interested parties and that feedback is encouraged.

- b. Procurement (OHSAS 18001 4.4.6; ANSI Z10 5.1.4)

Ensure that risks to health and safety from procured items are evaluated, establish requirements to mitigate those risks, and ensure that those requirements are met.

- c. Contracting and contractors (OHSAS 18001 4.4.6; ANSI Z10 5.1.5)

Assess and mitigate the impact of contractors' activities on worker health and safety and vice versa and establish procedures for coordinating the SMS between the organization and contractors.

- d. Incident investigation and reporting (OHSAS 18001 4.5.3.1; ANSI Z10 6.2)

Establish procedures for documenting and assessing incidents in a timely manner to identify deficiencies in the SMS or other factors leading to the incident.

- e. Audits (OHSAS 18001 4.5.5; ANSI Z10 6.3)

Define intervals and processes for implementing internal audits of the SMS to identify whether it is being applied appropriately and is effective.

- f. Inspections (API RP 75 Section 8.6)

Define what systems need to be inspected to protect worker health and safety, what inspections will be carried out and how often, acceptance criteria, and documentation.

- g. Records and documentation (OHSAS 18001 4.4.4/4.4.5; ANSI Z10 5.4)
Identify SMS records and documents that should be controlled to document the SMS and its effectiveness and support continual improvement.
- h. Performance monitoring, measurement, key performance indicators (KPIs) (OHSAS 18001 4.5.1; ANSI Z10 6.1)
Define how to monitor the effectiveness of the SMS by using KPIs and measures of conformance.
- i. Corrective and preventive actions (OHSAS 18001 4.5.3.2; ANSI Z10 6.4)
Define how to respond to deficiencies identified as part of the SMS, document the process, and track actions taken.
- j. Continual improvement (including program evaluation, management review) (OHSAS 18001 4.6; ANSI Z10 6.5/7)
Establish a process of periodic evaluations of the SMS to identify and act on areas of improvement.

The operator can use broadly grouped concepts in the outline above to supply the necessary details of the SMS. The individual concepts in the outline are more important than the categories themselves (e.g., planning or implementation) or their sequence, both of which can vary slightly depending on the standard or guidelines. Sections of appropriate standards are referenced in parentheses next to the concept, and a brief description is given. Table 5-1 shows the common SMS elements and relevant sections and compares them across management systems.

The committee is not in a position to recommend the use of one SMS standard over another; however, the committee believes that an SMS can provide organizations with a mechanism for continually improving their health and safety performance. An SMS can provide a more expansive approach to worker health and safety by identifying hazards and risks and presenting mitigation measures for all aspects of the wind farm development process, such as management policy, personnel safety, structures, and training. The documents and important concepts listed above are to be used as one guiding reference. Like the standards from which they originate, these concepts refer to the processes that should be followed but do not provide the necessary

TABLE 5-1 Common Elements Across SMSs, Identified by Document Section Number

SMS Element	Current										BSEE TA&R 709 (PMSS Sample SMS)	
	30 CFR 585	TA&R 686	API RP 75	IMO- ISM	2	3.1	MMS TA&R 633	Cape Wind SMS Description	ANSI/ AIHA/ ASSE Z10-2012	OSHA PSM 29 CFR 1910		OSHA Safety and Health Guidelines
Safety policy	810(a)	1a	1	2	3.1	6.2	4.3	3.1.2	4.2		c(1)(i)	2
Remote monitoring	810(b)						7					7
Emergency response and prevention	810(c)	2e	10	8	3.10.3	6.5.3	5.6	5.1.6	4.4.7	119n	c(2)(iii)	8
Fire suppression	810(d)						12					8
SMS testing	810(e)											14
Qualifications, training, competency	810(f)	1c	7	6	3.4	6.4	10.17; 10.18	5.2	4.4.2	119g	b(4)	4
Organization chart, responsibilities, authority	1b			3	3.3	6.3	4.2	3.1.3	4.4.1		c(1)(v), (vi)	3
Management commitment, worker participation	1d				3.2			3.2	4.4.3.2	119c	b(1); c(1)(iv)	14
Hazards analysis	2a	3	3	3.10.1			11	5.1.1	4.3.1	119e	b(2); c(2)	5, 9
Construction hazards	2a						11					9
Design, mitigation, hierarchy of controls	2b	2	2				13	5.1.2	4.3.1	119d	b(3); c(3)	5

Operating procedures	2c	5	7	6.5	119f	13
Safe work practices	2c	6			119k	8
Permit to work	2c			6.5.4		9
Security	2c			6.5.12	8	8
Simultaneous operations	2c			6.5.13		
Marine operations	2c		10	6.5.14		12
Health and fitness	2c		10.18.2			4
Site safety, first aid	2c		13			c(3)(iv)
Management of change	2d	4	3.10.2	6.3.2	4.7	5.1.3
Quality assurance, mechanical integrity, maintenance	2f	8	10			4.3.1
Commissioning	2g	9				119j
Communication	3a		3.6	6.5.9	6	5.3
Procurement	3b		3.10.4	6.5.18		4.4.3.1
Contracting, contractors	3c	App. A	3.10.5	6.5.20	9	5.1.4
Incident investigation and reporting	3d	11	9	3.12	6.6.2	5.1.5
Audits	3e	12	12	3.13	6.6.4	4.4.6
Inspections	3f	8.6				6.2
Records and documentation	3g	13	11	3.5	6.3.1.2	4.5.3.1
Performance monitoring, measurement, KPIs	3h		3.11	6.6	4.4	6.3
						4.5.5
						119h
						119m
						c(2)(iv)
						14.3
						14.4
						4.8
						4.6
						5.4
						4.4.4;
						4.4.5
						6.1
						4.5.1

(continued on next page)

TABLE 5-1 Common Elements Across SMSs, Identified by Document Section Number (continued)

SMS Element	Current										BSEE TA&R 709 (PMSS Sample SMS)				
	30 CFR 585	TA&R 686	API RP 75	IMO- ISM	2011	OSH 2011	ILO- OSH	MMS TA&R 633	Cape Wind SMS Description	Z10-2012		ANSI/ AIHA/ ASSE	OHSAS 18001	1910	OSHA PSM 29 CFR
Corrective and preventive actions					3.15					6.4	4.5.3.2				
Continual improvement (includes program evaluation, management review)					3.14; 3.16		5.1.2; 6.7	4.8.3		6.5; 7	4.6			c(1)(viii)	14
Environmental management							6.5.6	14							10
Objectives and programs											4.3.3			c(1)(ii)	
Evaluation of compliance											4.5.2				
Planning, risk management								4.5							
Trade secrets															119p

NOTE: AIHA = American Industrial Hygiene Association; ANSI = American National Standards Institute; API = American Petroleum Institute; ASSE = American Society of Safety Engineers; ASTM = American Society for Testing and Materials; BS = British Standard; BSEE = Bureau of Safety and Environmental Enforcement; CFR = Code of Federal Regulations; ILO = International Labour Organization; IMCA = International Marine Contractors Association; IMO = International Maritime Organization; ISM = International Safety Management Code; MMS = Minerals Management Service; NPPA = National Fire Protection Association; OHSAS = Occupational Health and Safety Assessment Series; OSH = Occupational Safety and Health; OSHA = Occupational Safety and Health Administration; PMSS = Project Management Support Services; RP = Recommended Practice; TA&R = Technology Assessment and Research; TRB = Transportation Research Board.

SOURCE: Generated by the committee.

details of procedures, job direction, or supporting documentation. Such details will vary according to the organization's policies and its project-specific tasks.

During the drafting of this report, BSEE commissioned another study that is developing an example SMS with appropriate detail and an auditing framework (see TA&R Report 709).¹ While the committee has only reviewed a draft version of the new study, it supports the objectives and believes that the study will provide additional guidance to lessees as they document their SMSs. In addition, a recently completed study (see Thomas 2012) on the effectiveness of SMSs was made available to the committee during the drafting of its final report. The committee was unable to review the report thoroughly but believes that it could be of great use to BOEM and BSEE as they enhance their SMS regulations.

The next section briefly discusses the relevant elements of the safety and environmental management system (SEMS) regulations for offshore oil and gas operations.

SAFETY AND ENVIRONMENTAL MANAGEMENT SYSTEM

As discussed in Chapter 3, Subpart S of 30 CFR 250 requires the lessee to develop, implement, and maintain a SEMS for offshore oil and gas operations on the basis of API's RP 75. This goal-based SMS became effective on November 15, 2011, and moved the regulations for offshore oil and gas operations from a primarily prescriptive system to a more risk-based system under which operators were required to demonstrate that the health and safety procedures described in the SEMS plan accomplished the stated goals. The shift away from a more prescriptive system was due in part to the inadequacy of an inspection process that encouraged compliance with checklists of potential incidents of noncompliance (PINCs) that tended to focus on preventing hardware-related mechanical failures. Previous reports indicated that most accidents occurring on the OCS were due to human factors or to not following proper procedures (Bea and Moore 1992; NRC 1990; TRB 2012). The rules in SEMS (for

¹ See <http://www.bsee.gov/Research-and-Training/Technology-Assessment-and-Research/Project-709.aspx>.

additional proposed rules in SEMS II, see *Federal Register* 2011a, 56683) require that operators demonstrate that the documented procedures and processes in the management system plan achieve the goals and that the personnel are competent to accomplish the safety goals. Most of the SEMS elements (listed below) are similar to the SMS concepts mentioned in the previous section (see Table 5-1).² As discussed in Chapter 2, the risk profiles of the offshore oil and gas and the offshore wind industries differ widely, so any adaptation of SEMS to the offshore wind industry would need to be risk-specific and require less oversight. Nevertheless, SEMS, like many SMSs, requires the following of operators:

1. General (30 CFR 250.1909)
Plan, implement, and manage all program elements discussed in API RP 75 (incorporated by reference) and to document the continued development, improvement, and success of SEMS plan.
2. Safety and environmental information (30 CFR 250.1910)
Establish written safety policies and processes and to document all hazards.
3. Hazards analysis (30 CFR 250.1911)
Conduct hazard analysis for each process.
4. Management of change (30 CFR 250.1912)
Set up a system that documents and manages any changes to the written policies and procedures.
5. Operating procedures (30 CFR 250.1913) and safe work practices (30 CFR 250.1914)
Develop written procedures and clear instructions to safely conduct all activities and hazardous operations.
6. Training (30 CFR 250.1915)
Ensure that employees and contractors are competent and properly trained to conduct activities and operations.
7. Mechanical integrity (30 CFR 250.1916)
Develop procedures for the integrity of process equipment.

² A SEMS and an SMS are not totally different systems, but they are not interchangeable. From a safety standpoint, the two systems have a similar focus, and the processes involved and elements within each are similar. Both the SMS and the SEMS focus on continual improvement and apply processes already in use for International Organization for Standardization quality and environmental management programs.

8. Pre-start-up review (30 CFR 250.1917)
Confirm during the commissioning stage that the construction and equipment are in accordance with appropriate design specifications.
9. Emergency response and control (30 CFR 250.1918)
Develop and implement an emergency response plan.
10. Investigation of incidents (30 CFR 250.1919)
Investigate each incident, including near misses.
11. Auditing (30 CFR 250.1920)
Perform audits and evaluate program compliance.
12. Record keeping (30 CFR 250.1928)
Document and report results of audits and evaluations.
13. Stop work authority (proposed in SEMS II) (30 CFR 250.1930)
Stipulate that all personnel have the ability to stop unsafe or hazardous work.
14. Ultimate work authority (proposed in SEMS II) (30 CFR 250.1931)
Identify the person with ultimate authority for a facility.
15. Employee participation (proposed in SEMS II) (30 CFR 250.1932)
Involve employees at all levels when preparing the management plan.
16. Guidelines for reporting unsafe work conditions (proposed in SEMS II) (30 CFR 250.1933)
Establish procedures for reporting unsafe work conditions.

As noted above and in a recent Marine Board report, the operator is responsible for ensuring that its SEMS program is functioning properly and evolving as operating conditions and situations change (TRB 2012). Nevertheless, how BSEE decides to enforce the SEMS program, or any safety management program, will determine its success: if BSEE only requires the submission of a SEMS program and enforces operators' compliance with a checklist of PINCs, operators will be less likely to take ownership of their safety programs (TRB 2012). A well-documented safety management plan is a necessary but not a sufficient condition for achievement of safe operations. An SMS is the foundation for building and supporting an organizational culture of safety and health, not a substitute for organizational commitment to continued safety performance. All employees, from top management through lower-level workers, must choose the correct and safe option

in every situation. For employees to do this, a positive culture of safety must exist (TRB 2012, 15–16). An SMS and a positive safety culture are closely linked: the SMS must consider all possible safety factors, while the safety culture will shape how an SMS is expressed within an organization.

FACTORS THAT SHAPE AND SUPPORT SMSs

Promoting a Positive Safety Culture

Full implementation of the types of SMS described in the previous sections depends on the quality of an organization’s safety culture. An organization’s safety culture is viewed as its “shared values (what is important) and beliefs (how things work) that interact with an organization’s structures and control systems to produce behavioural norms (the way we do things around here)” (Uttal as quoted by Reason 1998, 294). Safety culture reflects an organization’s commitment to safe operations—how safety is regarded and valued within an organization. Safety culture can be thought of not only as what an “organization ‘is’ ”—its “beliefs, attitudes, and values” in its “pursuit of safety”—but also as what an “organization has”—its “structures, practices, and policies” that “enhance safety” (Reason 1998, 294). For Reason (1998, 294), safety culture is the driving force behind a system’s safety achievements.

A culture of safety does not just appear. It develops over time as the organization matures and encourages all those within an organization to question aspects of their jobs and to establish open lines of communication. An effective safety culture is established and maintained through many of the following traits:³

1. Leadership that demonstrates safety values and ethics and actions,
2. Personal accountability,
3. Problem identification and resolution,
4. Work processes,
5. Continuous learning,
6. Environment for raising concerns,
7. Effective safety communication,

³ For more detail on each trait, see TRB 2012, 17–18, and NAE and NRC 2012, 92–93.

8. Respectful work environment, and
9. Questioning attitude.

To ensure a culture of safety, the organization needs a mechanism describing and documenting safe operations (an SMS plan), and it must institute actions that establish safety norms and provide for accountability. Individual workers must be able to demonstrate competency, motivation, and implicit authority to recognize unsafe conditions and report them without retribution. Competency is built by developing knowledge and skills through training and experience, while motivation is achieved through a commitment that the individual will act according to the norms of the organization. To achieve safe operations, individuals at all levels of an organization must have this commitment to safety, and the organization, especially top management, must support this commitment through its culture. This is true of any organization, regardless of the regulatory system (TRB 2012, 19).

The wind industry has made the case for pursuing a safety culture at recent workshops and industry conferences. As discussed at a recent workshop, making a culture of safety a vital element of all phases of offshore development should be a top priority across the wind industry, and the use of best practices from the oil and gas industry is one approach for achieving this goal.⁴ Some wind industry representatives are attempting to manage risk more systematically while promoting a positive safety culture. In the United Kingdom, the risks involved in each offshore wind project become more noticeable as the size and scale of projects increase. Risk management has become more complex as sites and locations of projects are pushed farther out to sea into more extreme environments. Accordingly, the wind industry is trying to establish a balanced approach to safety that considers both occupational and system safety. An organizational culture of safety should exist throughout the entire life cycle of the project, and it starts with the commitment of the top leadership to implement policies that focus on reward, recognition, and organizational correction to motivate the entire workforce.⁵ Similarly, Wolf believes that

⁴ See D. Porter, GL Noble Denton, and T. Abbasi, Genesis Oil and Gas, presentations at the Offshore Energy Knowledge Exchange Workshop, Washington, D.C., April 11–12, 2012. http://www.wind.energy.gov/pdfs/offshore_energy_knowledge_exchange_workshop_report.pdf.

⁵ Chris Streatfeild, presentation at American Wind Energy Association Safety Conference, January 9–12, 2012.

leadership is critical.⁶ Leaders should communicate regularly with their employees, foster teamwork, and provide positive reinforcement of safety activity involvement. The organization should encourage employee participation in safety training and commit to continuous improvement.

As noted above, well-documented procedures contained in safety management plans are a necessary condition for achieving safe operations, but strong leadership that implements policies promoting a positive safety culture at all organizational levels is critical for the success of those plans. The importance of measuring safety performance, reporting outcomes, and implementing corrective actions is discussed in the next section.

Key Performance Indicators

The safety management process aims for a cycle of continual improvement of safety performance. The successful interplay between an organization's SMS and its safety culture requires the monitoring of KPIs, which are general measures used in assessing performance. They may be associated with many of an organization's key activities and are not necessarily related to safety. KPIs can include leading indicators and trailing or lagging indicators. Leading indicators are proactive measures that can suggest the possibility of an incident or the presence (or lack) of safety culture. Examples of leading indicators include hazards identified and addressed, the number of safety meetings that involve management, the size of the organization's safety budget, and the number of safety inspections conducted during a given time period. Trailing or lagging indicators are reactive measures after an event or accident and tend to gauge past trends or performance (e.g., lost work days or injuries per time period) or outcome assessments (ABS 2012). Any attempt to measure safety performance must ensure that results are both valid and reliable. Safety metrics are considered valid indicators if they accurately measure characteristics of safety performance, and reliable safety metrics will consistently predict results for safety performance over time.

In 2011, in an effort to measure safety performance, the American Wind Energy Association (AWEA) launched its first survey of worker

⁶ Gary Wolf, presentation at American Wind Energy Association Safety Conference, January 9–12, 2012.

safety and health to collect injury, illness, and fatality data specific to the wind energy industry. At the time, the wind energy sector did not have a dedicated North American Industry Classification System⁷ code to calculate injury and illness data from the Bureau of Labor Statistics. To resolve this issue, AWEA sought to benchmark industry safety data by implementing an anonymous survey based on the current OSHA 300 log. AWEA hopes to provide the data to its members as a way to compare themselves with peers. Just over one-third of its members participated in the first injury and illness data collection survey, and AWEA hopes to encourage more of its members to share data.⁸ If participation rates increase, AWEA plans to expand its survey collection efforts. However, some company representatives noted at a recent conference that individual companies may be less willing to share health and safety data because of concerns with regard to potential litigation or greater regulatory scrutiny.⁹

The wind industry has generally urged the use of leading indicators as a way of assessing the effectiveness of safety performance and preventing injuries. Some manufacturers have used indicators such as the number of hazard reviews, emergency or safety drills, and corrective actions taken but tailor the measures to include items within the individual's span of control. For example, indicators for managers might focus on activities including the number of safety meetings conducted or the number of corrective actions taken, while indicators for technicians might emphasize behaviors as an example to others—skill acquisition or near-miss reporting.¹⁰

Indicators are useful in identifying trends and areas on which to focus. For example, one company's recent internal assessment reported that 40 percent of injuries were due to sprains or strains.¹¹ This report initiated an internal ergonomic study that found the need for additional

⁷ The North American Industry Classification System is the standard used by federal statistical agencies in classifying business establishments for the purpose of collecting, analyzing, and publishing statistical data related to the U.S. business economy.

⁸ Michele Mihelic, AWEA, December 1, 2011, presentation to the committee.

⁹ Discussion at AWEA WindPower 2012, Safety Committee Meeting, Atlanta, Georgia, June 3–6, 2012.

¹⁰ Todd Karasek, presentation at AWEA WindPower 2012, Atlanta, Georgia, June 3–6, 2012.

¹¹ Manny Sanchez, presentation at AWEA WindPower 2012, Atlanta, Georgia, June 3–6, 2012.

ergonomic training. A separate study conducted by the Electric Power Research Institute focused on ergonomics and worker health safety in the wind industry and collected and analyzed data on specific task requirements. The study suggested that changes in engineering controls, such as tools and equipment (lighter manual impact wrenches and better knee pads), as well as in structural design, such as larger hatch openings and more head clearance in the nacelle, could decrease the likelihood of injuries.¹²

Developing metrics and collecting data are important tools for management in reporting outcomes, setting strategy, supporting decision making, and implementing corrective actions to improve safety performance. The next section reviews inspections and audits as currently required in 30 CFR 585 and discusses their importance in assessing and evaluating a program or activity.

Inspections and Audits

An inspection is a structured assessment of an activity or an item that includes measures and tests to determine whether it possesses certain characteristics compared with specified requirements or standards. An audit is a systematic evaluation of an activity or program to determine whether it is being managed or maintained according to a set of accepted standards. This section reviews the requirements for inspections and audits given in 30 CFR 585.

BOEM Inspections

The regulations in §585.820, which were introduced in Chapter 3, allow BOEM to conduct scheduled and unscheduled inspections of a lessee's facilities and vessels to verify that all project activities are being conducted in compliance with the terms of the lease. The lessee must provide access to all facilities and areas listed on the lease and provide all records of design, installation, operations and maintenance, repairs, or investigations on or related to the project area. Furthermore, the lessee must demonstrate compliance with its own SMS (*Federal Register* 2011b, 64774). To inspect an offshore wind facility, an inspector would need to

¹² Richard Marklin et al., presentation at AWEA Safety Conference, January 9–12, 2012.

compare the facility against some minimum requirements. However, at the time of this report BOEM has not “developed a formal policy on our inspection process for offshore wind farms.”¹³ BOEM is considering the SEMS inspection process that is under development for oil and gas as a model, along with the inspection guidance from two other TA&R reports (see *Energo Engineering* 2009, 2010).¹⁴

In the absence of detailed requirements, BOEM has published a *Process Guide* (see BOEMRE 2011) to clarify the offshore renewable energy process, including inspections. However, little detail is provided. For example, Annex 1 of the *Process Guide* states that BOEM will conduct inspections of facilities and vessels engaged in renewable energy activities to ensure that operators comply with the regulations in 30 CFR 285, including the operator’s SMS. Furthermore, BOEM will conduct oversight inspections of a lessee’s self-inspection plan (described below), and the United States Coast Guard will continue to inspect and certify vessels under its jurisdiction.

In addition to its *Process Guide*, BOEM and BSEE have published a list of PINCs for renewable energy, developed in August 2009 after the release of the renewable energy regulations contained in 30 CFR 285. A sample of relevant renewable energy PINCs is shown in Box 5-1.

Each PINC is numbered and corresponds to a specific requirement in 30 CFR 585. Inspection procedures for renewable energy projects are listed in the PINC document, and inspectors use a checklist of procedures to verify that each component of the regulation is in place or in compliance. If an incident of noncompliance (INC) is determined, the inspector issues one of three enforcement actions: warning [(W) INC], component shut-in [(C) INC], or facility shut-in [(S) INC].

Relying on PINCs for enforcement can create problems. As previous Marine Board studies have pointed out, using a checklist of PINCs to determine compliance with a set of safety regulations could encourage companies to adopt a passive attitude that equated safety with passing the inspection (NRC 1990; TRB 2012). Instead of identifying and correcting safety issues proactively and assessing performance over time, companies would wait for a regulator to detect the violation and to explain the required corrective action, which would lead “to a culture of

¹³ John Cushing, BSEE, e-mail communication, September 14, 2012.

¹⁴ John Cushing, BSEE, e-mail communication, September 14, 2012.

BOX 5-1

Examples of PINCs for Renewable Energy

T-101 DOES THE LESSEE CONDUCT ALL ACTIVITIES IN A SAFE MANNER?

Authority: 30 CFR 285.105

Enforcement Action: W/C/S

INSPECTION PROCEDURE:

Observe all activities for unsafe and/or unworkmanlike practices, procedures, or operations covering safety.

T-112 DOES THE LESSEE'S SAFETY MANAGEMENT SYSTEM (SMS) DESCRIBE HOW THEY WILL ENSURE SAFETY OF PERSONNEL OR ANYONE ON OR NEAR THEIR FACILITIES?

Authority: 30 CFR 285.810(a)

Enforcement Action: W/C/S

INSPECTION PROCEDURE:

1. Verify that lessee's SMS plan includes procedures, which directly address human factors issues associated with the interaction between facility and personnel.
2. Verify that these procedures address safe and environmentally sound operations.

T-116 DOES THE LESSEE'S SAFETY MANAGEMENT SYSTEM (SMS) DESCRIBE HOW AND WHEN THE SAFETY MANAGEMENT SYSTEM WILL BE TESTED?

Authority: 30 CFR 285.810(e)

Enforcement Action: W/C/S

INSPECTION PROCEDURE:

1. Verify that Lessee's SMS include a test program and procedures that covers:
 - a. The activities and areas to be considered in tests
 - b. The frequency of tests

- c. The test team
 - d. How test will be conducted
 - e. Test reporting
2. Verify through records review that SMS is being tested.

T-117 DOES THE LESSEE'S SAFETY MANAGEMENT SYSTEM (SMS) DESCRIBE HOW LESSEE WILL ENSURE PERSONNEL WHO OPERATE THEIR FACILITY ARE PROPERLY TRAINED?

Authority: 30 CFR 285.810(f)

Enforcement Action: W/C/S

INSPECTION PROCEDURE:

Verify that

1. Procedures are developed to ensure that persons assigned to operate and maintain the facility possess the required knowledge and skills to carry out their duties and responsibilities;
2. Lessee's training plan includes procedures on verifying that employees received training once any alterations in facilities require new or modification of existing operating procedures; and
3. Lessee's training plan includes procedures on verifying that employees received training on operating procedures, safe work practices, and emergency response and control measures.

The complete list of renewable energy PINCs is available at <http://www.bsee.gov/Inspection-and-Enforcement/GLT-pdf.aspx>.

compliance rather than a culture of safety” (NRC 1990; TRB 2012). The studies also note that inspection checklists can be useful mechanisms in combination with other means of enforcement. A checklist will determine whether an item (e.g., proper documentation) corresponds correctly with a specific requirement, but the inspector is also in a position to ask personnel more in-depth questions about safety procedures and their role in the process—information that could help identify problems proactively and guide audits and the assessment of the whole SMS.

Self-Inspections

Under the regulations in §585.824, each lessee is required to develop and conduct an annual self-inspection plan for all facilities and make the plan available to BOEM on request. The plan must include such details as the type, extent, and frequency of inspections to be conducted for relevant structures and components, as well as an assessment of structural integrity.¹⁵ The lessee must submit an annual report to BOEM listing all facilities inspected over the previous 12 months, the type of inspection, and a summary of actions. The requirements for self-inspections by lessees do not indicate other specific assessments (e.g., worker health and safety), and Annex 1 of the *Process Guide* restates that the lessee must develop a self-inspection plan, conduct an annual self-inspection, and submit an annual self-inspection report (BOEMRE 2011, 15). Other guidance on self-inspections from the agency refers lessees to TA&R Reports 627 and 650 (see Energo Engineering 2009, 2010).¹⁶

Certified Verification Agent

Under 30 CFR 585, an approved certified verification agent (CVA) (or a company's own project engineer if BOEM approves a waiver) must review and certify the facility design report and the fabrication and installation report. The CVA must independently assess and certify to BOEM that the facility is designed according to sound practices and that components are installed according to acceptable practices (*Federal Register* 2011b, 64771). However, the CVA neither assesses these reports for worker health and safety nor reviews the SMS submitted to BOEM.

Audits

BOEM Audits Although auditing is an important element in SMS standards, the regulations set forth in 30 CFR 585 require neither internal audits nor audits by BOEM. According to Annex 1 of the *Process Guide*, BOEM will conduct “oversight inspections and audits of the company’s self-inspection program” (BOEMRE 2011, 15). BOEM has not developed a formal audit process but envisions the process having at least two elements: the audit of

¹⁵ *Federal Register* 2011b, 64775, assessment of the structure based on the platform assessment initiators listed in API RP 2A-WSD, which is incorporated by reference.

¹⁶ John Cushing, BSEE, e-mail communication, September 14, 2012.

the lessee's self-inspection plan and report and the audit of the lessee's SMS. Although the criteria for the audits are not developed, the agency indicates that both the TA&R Reports 627 and 650 (see Energo Engineering 2009, 2010) and the SEMS auditing process under development for the oil and gas industry will provide guidance for its audit process.¹⁷

Comprehensive audits by BOEM would be vital in verifying that the operator's SMS audits are being conducted properly and that the lessee's managers are reviewing SMS audit reports and taking any necessary corrective action. In combination with reports from BOEM inspectors and the lessee's self-inspection plans and reports, BOEM audits would provide another tool for determining whether the operator's SMS improves health and safety. This view is echoed in the recent SEMS report, which recommended a "holistic combination of methods" for ensuring an effective and continuously improving safety program that includes compliance inspections and audits (TRB 2012).

Internal Audits Internal or operator audits are critical because they determine whether an organization manages and maintains its SMS in accordance with accepted standards. The frequency of a lessee's internal audits should be sufficient to provide feedback to the organization's planning process and should help in its continual improvement of performance. An audit should not merely focus on an organization's written policies and procedures. It should ensure that the SMS program accurately reflects how personnel incorporate health and safety into everyday tasks and assess whether the organization continually supports safety and health, including identification of hazards and management of risks. As noted in a recent Marine Board study, an internal audit is more effective when it is performed by independent teams of the operator that are not associated with the activities being reviewed because such an arrangement "reinforces ownership" of the process and of the organization's "safety culture" (TRB 2012). If small organizations need to use third-party auditors, the audit team should include some internal personnel who are not directly involved with the activities being

¹⁷ John Cushing, BSEE, e-mail communication, September 14, 2012.

reviewed. Information on conducting an internal or operator audit is found in OHSAS 18001-4.5.5 and in ANSI/AIHA Z10-6.3, and Annex I of ANSI/AIHA Z10–2005 provides a sample audit plan (see pp. 46–50).

Summary

With the exception of a list of PINCs for renewable energy, BOEM’s procedures and requirements for inspecting and auditing an offshore wind farm’s SMS are not yet well developed. As formal policies of inspections and audits are developed, BOEM will need to ensure that its inspection process places the responsibility of safety compliance on the lessee and not on BOEM itself through a checklist of PINCs. Internal or operator audits help a company internalize a safety culture and encourage “ownership” of the company’s safety program. BOEM can ensure that the lessee’s internal audits are conducted appropriately through its own audits. The next section discusses the importance of properly trained personnel.

Training

Several sections of the 30 CFR 585 regulations require that lessees use “properly trained personnel,” and in accordance with §585.810, lessees must describe how they will ensure that personnel who operate their facilities are properly trained.

Information on processes for training, awareness, and competence is given in OHSAS 18001-4.4.2 and in ANSI/AIHA Z10-5.2. Determining the minimum training needs of the workforce is an ongoing process and depends on the roles, responsibilities, and associated risks of each position, and minimum training requirements can differ among organizations. The committee learned from presentations that many companies in the wind industry already have comprehensive health and safety training programs, but the programs lack consistency among companies. Technicians often face redundant safety training and courses to receive certification to work on turbines from different manufacturers. Consistent guidelines for minimum training requirements and recognition of competency (competent person qualification) could help address the issue of redundancy, and industry could collaborate in developing such guidelines.

As mentioned in Chapter 3, the AWEA Training and Education Subcommittee is creating a course training manual for a qualified electrical

worker that presents basic guidelines and elements that all companies should include in their training. The subcommittee is developing introductory safety training manuals for the wind industry. AWEA facilitated a 3-day class through which OSHA compliance officers attended a training program at an AWEA member's facility. In addition, the Global Wind Organisation, an association of wind turbine owners and manufacturers, has the goal of standardizing the content of safety and preparedness training courses for personnel working in the wind industry and has drafted guidelines for a basic safety training course on the basis of input from its members. These initiatives suggest proactive attempts to address industry's need for safety training that have implications for the training of BOEM personnel as well.

As for government inspectors and auditors, at present neither BOEM nor BSEE has established training programs for offshore wind inspectors. To carry out its mandate to conduct health and safety inspections of wind farms, BOEM will require well-trained personnel who understand the hazards and risks of the industry they are regulating. As BOEM works toward clarifying its SMS requirements, the agency will need to hire personnel and ensure that they are adequately trained. Until the scope of offshore wind farm development is understood, any training program will require scalability as the offshore wind industry develops and grows.

BSEE, which enforces safety and environmental regulations on the OCS, operates the National Offshore Training and Learning Center (NOTLC). NOTLC's mission is to enhance the capabilities of BSEE inspectors in enforcing safety and environmental regulations through evolving technical curricula and specialized training that adapts to emerging technologies and processes.

The next section provides a brief overview of how human factors engineering (HFE) and prevention through design (PtD) could provide an important resource for improving worker health and safety.

ROLE OF DESIGN IN WORKER HEALTH AND SAFETY

Previous research has shown that people have measurable capabilities and limitations that affect their ability to perform their jobs in a safe and efficient manner. If facilities were designed to match such capabilities

and limitations, injuries could be reduced or eliminated. HFE improves the interface between workers and the systems and equipment they operate and maintain by incorporating elements of management participation, workplace design, environmental control, and job aids into the design and operation of a safe and efficient work site. In the offshore oil and gas industry, HFE is associated with the design, layout, and labeling of equipment and control panels and with the establishment of the working physical environment and design requirements.

The HFE discipline identifies what humans can do (capabilities), cannot do (limitations), and will do (motivations and rewards) and attempts to minimize occurrences of “human error” through design and other controls.¹⁸ The involvement and support of management in HFE ensure the establishment of effective safety policies and procedures (including those for a safe workplace) and training programs and the creation of an overall corporate safety culture. Without the interest, commitment, and support of management, the prospects for designing and operating a safe and efficient work site diminish.

Incorporating HFE elements into the design of offshore structures is important for reasons of safety and cost. One study reports that 80 percent of all offshore oil and gas incidents in U.S. waters were due to human error, and more than half of those errors occurred during operations (Bea and Moore 1992). Another study found that human-induced incidents outnumber machinery and structural failure incidents and that by addressing human-induced incidents through HFE, overall worker safety would improve and protection of the environment would increase.¹⁹ Van Uden and Rensink (1998, 1999) reported that incorporation of HFE elements into the design of a \$400 million petrochemical facility reduced operational and maintenance costs by 3 to 6 percent over the life cycle of the project and reduced the total number of engineering hours required for the project by 1 percent.

For the oil and gas industry, incidents that occur on offshore facilities are one of two types: personal events and large events. Personal events, which involve a limited number of people and amount of dam-

¹⁸ G. E. Miller, presentation to the committee, May 31, 2012.

¹⁹ G. E. Miller, presentation to the committee, May 31, 2012.

age, account for a significant number of injuries on offshore oil and gas structures. Large events occur infrequently but are usually major accidents with many fatalities and significant damage and loss. Considerable experience indicates that the introduction of HFE elements into the design and operating process could reduce the number of personal events on offshore facilities.²⁰ Because of their nature, large events are more likely to be system safety issues and are less likely to be reduced by the introduction of HFE elements alone. The conditions that cause large, catastrophic events in the oil and gas industry, such as the *Deepwater Horizon* explosion, are not present on offshore wind farms. Wind turbines are unmanned and are spread over a large area, so a limited number of workers are exposed to hazards at any one time. Emphasizing the reduction of personal events through the introduction of HFE elements could greatly improve worker health and safety for offshore wind farms.²¹

As mentioned above, Subpart S of 30 CFR 250 is the SEMS based on API RP 75, and the oil and gas industry is encouraged to plan, implement, and manage all of the elements listed in RP 75. Section 2 of RP 75 states that human factors should be considered in designing and installing new facilities or completing major modifications and points to ASTM²² F1166-95, *Standard Practice for Human Engineering Design for Marine Systems, Equipment, and Facilities* (ASTM 2007) as a good resource for HFE design elements. The ASTM F1166 standard (updated in 2007, with the next revision planned for 2013) is a well-known HFE design standard document in the U.S. offshore oil and gas industry and provides engineers and designers the specific human-based design criteria that can eliminate or reduce the likelihood of the identified hazard.

Another important resource is the PtD initiative led by the National Institute for Occupational Safety and Health (NIOSH) of the U.S. Centers for Disease Control and Prevention. PtD is based on the premise that the design process is the best place to “design out” hazards and risks. Address-

²⁰ G. E. Miller, presentation to the committee, May 31, 2012.

²¹ G. E. Miller, presentation to the committee, May 31, 2012.

²² The American Society for Testing and Materials now uses the name ASTM International. It develops and delivers international voluntary consensus standards. More information is available at <http://www.astm.org/index.shtml>.

ing hazards and risks early in the process is a key strategy for reducing workplace injuries and fatalities. According to the NIOSH website, PtD is defined as “addressing occupational safety and health needs in the design process to prevent or minimize the work-related hazards and risks associated with the construction, manufacture, use, maintenance, and disposal of facilities, materials, and equipment.”²³ The PtD initiative has also helped in the development of the voluntary consensus document ANSI/ASSE Z590.3-2011, *Prevention Through Design Guidelines for Addressing Occupational Hazards and Risks in Design and Redesign Processes* (ANSI and ASSE 2011). The ANSI/ASSE Z590.3 standard is a design approach that offers direction on how to identify health and safety hazards and quantify the severity of the risks during the process of design and redesign; however, it does not replace other design standards, such as ASTM F1166. Instead, the ANSI/ASSE document complements the performance objectives of design standards. The ANSI/ASSE standard describes a design approach and recommends a general solution for preventing hazards, while the ASTM F1166 design standard provides specific human-based design criteria that can help reduce or eliminate the likelihood of the hazards.

Addressing hazards and risks early in the design process is recognized as a key strategy for reducing or eliminating workplace injuries and fatalities. Both the HFE discipline and the PtD initiative provide opportunities to identify hazards and reduce their likelihood during the design phase, and, in the opinion of the committee, are a vital element for any submitted SMS.

SUMMARY DISCUSSION

An SMS can be an effective approach for ensuring worker health and safety if the organization embraces it and if the SMS reflects a positive safety culture. BOEM has a general SMS requirement in §585.810 that contains a limited number of necessary elements to guide operators. Although this committee is not in a position to recommend the use of one SMS standard over another, SMS standards often follow the plan-do-check-act process and provide a starting point for developing

²³ <http://www.cdc.gov/niosh/topics/ptd/>.

an effective safety regimen. The committee has included a base list of common SMS concepts and believes that any SMS would benefit from following the indicated processes.

The SEMS regulations in 30 CFR 250 for the oil and gas industry based on API RP 75 are also an important goal-based model for BOEM's SMS. Although many of the SEMS elements are similar to those of other SMS standards, SEMS would need to be applied to the wind industry differently from how it is applied to the oil and gas industry. Regulations for wind farm workers relying on a SEMS framework would require less oversight than for the oil and gas industry and would depend on the amount of associated risk. Regardless, any proposed SMS will need a positive safety culture to reinforce an organization's safety goals, which BOEM can assess through inspections and audits. Organizations also need valid and reliable indicators to assess their safety performance and monitor their continued improvement. Properly conducted inspections and audits are a necessary part of enforcing an effective SMS but need appropriately documented procedures and training to be successful. Internal audits are critical in reinforcing ownership of an operator's SMS process and its culture of safety. Finally, by encouraging the use of HFE and PtD elements in the design process, industry can help to reduce human factor incidents, which, research has shown, contribute to more accidents and incidents in the maritime and offshore industries worldwide than any other single factor.

REFERENCES

Abbreviations

ABS	American Bureau of Shipping
ANSI	American National Standards Institute
ASSE	American Society of Safety Engineers
ASTM	American Society for Testing and Materials
BOEMRE	Bureau of Ocean Energy Management, Regulation, and Enforcement
NAE	National Academy of Engineering
NRC	National Research Council
TRB	Transportation Research Board

ABS. 2012. Guidance Notes on Safety Culture and Leading Indicators of Safety. Houston, Tex. http://www.eagle.org/eagleExternalPortalWEB/ShowProperty/BEA%20Repository/Rules&Guides/Current/188_Safety/Guide.

- ANSI and ASSE. 2011. *Prevention Through Design Guidelines for Addressing Occupational Hazards and Risks in Design and Redesign Processes*. ANSI/ASSE Z590.3-2011. Des Plaines, Ill.
- ASTM. 2007. *Standard Practice for Human Engineering Design for Marine Systems, Equipment, and Facilities*. ASTM F1166-07. West Conshohocken, Pa.
- Bea, R. G., and W. H. Moore. 1992. Operational Reliability and Marine Systems. In *New Challenges to Understanding Organizations* (K. H. Roberts, ed.), Macmillan, New York.
- BOEMRE. 2011. *Process Guide: Offshore Renewable Energy Installations*, and Annexes 1–4, Version 1.0. July 27.
- EnergO Engineering. 2009. *Inspection Methodologies for Offshore Wind Turbine Facilities*. MMS TA&R No. 627, Jan.
- EnergO Engineering. 2010. *Offshore Wind Turbine Inspection Refinements*. MMS TA&R No. 650, June.
- Federal Register*. 2011a. Oil and Gas and Sulphur Operations in the Outer Continental Shelf—Revisions to Safety and Environmental Management Systems. Vol. 76, No. 178, Sept. 14, pp. 56683–56694.
- Federal Register*. 2011b. Reorganization of Title 30: Bureaus of Safety and Environmental Enforcement and Ocean Energy Management. Vol. 76, No. 201, Oct. 18, pp. 64432–64780.
- NAE and NRC. 2012. *Macondo Well—Deepwater Horizon Blowout: Lessons for Improving Offshore Drilling Safety*. National Academies, Washington, D.C.
- NRC. 1990. *Alternatives for Inspecting Outer Continental Shelf Operations*. National Academy Press, Washington, D.C.
- Reason, J. 1998. Achieving a Safe Culture: Theory and Practice. *Work and Stress*, Vol. 12, No. 3, pp. 293–306. <http://www.raes-hfg.com/reports/21may09-Potential/21may09-JReason.pdf>.
- Thomas, M. J. W. 2012. *A Systematic Review of the Effectiveness of Safety Management Systems*. Australian Transport Safety Bureau Final Report. Dec. <http://www.atsb.gov.au/publications/2012/xr-2011-002.aspx>.
- TRB. 2012. *Special Report 309: Evaluating the Effectiveness of Offshore Safety and Environmental Management Systems*. Transportation Research Board of the National Academies, Washington, D.C. <http://www.trb.org/Publications/Blurbs/167249.aspx>.
- Van Uden, M. E. J., and H. J. T. Rensink. 1998. Human Factors Engineering in Petrochemical Projects, Part I. *Petroleum Technology Quarterly*, Summer.
- Van Uden, M. E. J., and H. J. T. Rensink. 1999. Human Factors Engineering in Petrochemical Projects, Part II. *Petroleum Technology Quarterly*, Spring.

Findings and Recommendations

The committee's charge was to assess the U.S. Department of the Interior's (DOI's) approach for regulating the health and safety of wind farm workers on the outer continental shelf (OCS). The committee's three main tasks were to identify unique risks to worker health and safety on wind farms as compared with oil and gas operations on the OCS (see Chapters 2 and 4), to identify any gaps or overlaps in jurisdictional authority (see Chapter 3), and to evaluate the adequacy of and recommend enhancements to current regulations for worker health and safety on OCS wind farms (see Chapters 3 and 5).

The U.S. federal government has regulated the production of offshore oil and gas for decades, but it has no experience with offshore wind farms. Although land-based and offshore wind development share many hazards, the challenge of working on and from vessels and in and over the water with massive offshore wind turbine equipment introduces additional hazards and different risks. As discussed in Chapter 2, the oil and gas and wind industries share many of these offshore hazards, and the risk associated with oil and gas hazards is compared with that for offshore wind. The oil and gas industry works with a volatile product, so the risk of explosion or fire on offshore platforms is greater than on an offshore wind turbine. Furthermore, offshore drilling platforms are larger, manned by more personnel, and pose a greater ongoing risk to human life and the environment than does an unmanned wind turbine.

Chapter 3 discussed the jurisdictional issues involved in regulating worker health and safety for offshore and land-based wind farms. Given the history of regulating health and safety in the United States, overlapping—and possible gaps in—jurisdiction among multiple federal agencies has created confusion as to which regulations apply and

when and where they apply. Normally, the Occupational Safety and Health Administration (OSHA) would have jurisdiction for private-sector worker health and safety regulations in the United States, including the OCS. However, in accordance with Section 4(b)(1) of the Occupational Safety and Health Act, DOI's intention of enforcing worker health and safety regulations for wind energy by requiring the lessee to submit a description of a safety management system (SMS) has preempted OSHA from enforcing its regulations on the OCS. OSHA does regulate health and safety for land-based wind farms and has indicated that it will regulate offshore wind farms in state waters within 3 nautical miles and on the Great Lakes. The United States Coast Guard (USCG) regulates the safety of life and property on OCS facilities engaged in exploring and exploiting mineral resources but has declared itself a cooperating agency to the Bureau of Ocean Energy Management (BOEM) for renewable energy activities, allowing BOEM to be the lead agency.

The committee examined current DOI regulations in Chapter 3 and presented other SMS models—and baseline SMS elements—in Chapter 5 that could guide BOEM in developing and enhancing its own requirements and standards. Chapter 5 also discusses factors that shape and support a well-developed SMS, such as an organizational culture of safety, performance indicators and monitoring, inspections and audits by both the regulator and the operator, and training. Finally, the use of human factors engineering (HFE) elements in the design process is introduced, and its relevance and application to the protection of worker health and safety are discussed. The committee's consensus findings and recommendations are presented below.

Finding 1. Under the authority of Section 388 of the Energy Policy Act of 2005, DOI's BOEM is responsible for regulating worker safety on offshore wind farms on the OCS.

BOEM's Office of Renewable Energy has leasing, permitting, and enforcement authority for offshore wind energy (see 30 CFR 585). DOI's Bureau of Safety and Environmental Enforcement (BSEE) develops and enforces safety and environmental regulations for oil and gas operations, but not for wind energy. During the drafting of this report, however, the sponsor reported to the committee that BSEE expects to conduct safety compliance inspections of offshore renewable energy facilities

by 2014, consistent with the original intent of the Minerals Management Service–Bureau of Ocean Energy Management, Regulation, and Enforcement reorganization and parallel to the arrangement for oil and gas. The committee endorses DOI’s intention of resolving jurisdictional responsibilities between BSEE and BOEM with regard to wind energy on the OCS in a manner similar to the resolution of responsibilities for oil and gas—with BOEM being responsible for resource management and BSEE being responsible for health and safety compliance.

Finding 2. Federal regulations and oversight with regard to worker health and safety on offshore renewable energy installations (OREIs) on the OCS are not well developed. To date, BOEM has issued a general requirement that operators provide a safe working environment by submitting a description of an SMS as required by 30 CFR 585.810, but without benchmarks or minimum detail as to what should be included.

Finding 3. An SMS can be effective in ensuring worker health and safety if organizations embrace it and if the SMS reflects a positive safety culture. However, standards are only effective if they are sufficiently detailed that the regulated entity understands what is required for compliance.

BOEM has a general SMS requirement in §585.810 that lacks many important elements and details necessary for guiding operators adequately. Chapter 5 of this report reviews elements in published SMS standards and sets forth concepts needed for any SMS. An SMS identifies hazards and associated risks and presents mitigation measures for all aspects of the wind development process. SMS standards that follow the typical “plan-do-check-act” process can be used as an effective model and provide the foundation for an effective safety culture, which is key to sustainable safety. This process is necessary but not sufficient for achieving safe operations, however—a successful SMS also requires strong leadership that implements policies and promotes a positive safety culture at all levels of the organization. Although the committee does not recommend the use of one SMS standard over another, it does believe that an SMS provides organizations with a mechanism for verifying that its health and safety policies and procedures produce the

intended results, for taking corrective action as necessary, and for continually improving its health and safety performance.

Finding 4. Because the offshore wind farm industry in the United States is just beginning to develop, a regulatory framework that facilitates continued progress while ensuring protection of worker health and safety is desirable. **Goal-based regulations could allow the appropriate flexibility needed for technological changes and continued development.** Requiring an SMS that is comprehensive and effective in practice is preferred, but a hybrid approach may be necessary. To maximize the protection of worker health and safety, a comprehensive and effective SMS is likely to require additional details governing the control of specific hazards. In some cases, specific hazards will require more detailed prescriptive requirements.

Finding 5. Some of the safety and environmental management system (SEMS) requirements for the offshore oil and gas industry would be appropriate for offshore wind farm worker health and safety and could be adapted to regulations for offshore wind installations. However, the overall risk to the health and safety of workers and to the environment associated with an offshore oil and gas platform is greater than that associated with an offshore wind turbine.

BSEE's SEMS rule applies to workers in offshore oil and gas operations and incorporates the elements from American Petroleum Institute (API) Recommended Practice (RP) 75. The SEMS rule lays out multiple requirements for safe operations that are consistent with other SMSs reviewed by the committee and are compared in Chapter 5. Since the risk profiles of the offshore oil and gas and offshore wind industries are different, any regulatory framework adapting SEMS for the offshore wind industry would need to be risk-specific and would require less oversight than for the oil and gas industry.

Recommendation 1a. While engaging with stakeholders, BOEM should undertake rulemaking and adopt a full SMS rule at a level of detail that includes the baseline elements identified in Chapter 5 of this report or at a level comparable with that of the SEMS for the oil and gas industry. BOEM and BSEE should investigate the appropri-

ateness of adapting SEMS for the offshore wind industry. In addition, any new rule should require the lessee to submit any resulting SMS to BOEM and BOEM to review the SMS against the new SMS rule.

Under BOEM's SMS requirement in 30 CFR 585.810, operators must submit a description of their SMS, but the requirement does not provide industry the necessary detail of well-defined regulations. Chapter 5 presents SMS elements from published standards and other documents and provides BOEM with the concepts necessary for developing and approving the full SMS rule. BSEE's SEMS regulations in Subpart S of 30 CFR 250 provide significantly more detail than the current §585.810 requirements. BSEE is expected to conduct safety compliance inspections of offshore renewable energy facilities, and BOEM and BSEE should study the appropriateness of SEMS for the offshore wind industry. Engaging wind energy stakeholders early in the rulemaking process can improve the chances of implementing a comprehensive and effective SMS rule. The development of Subchapter M of 46 CFR, discussed in Chapter 3, provides an example of a process under which the engagement between a regulator and stakeholders produced an SMS requirement that advanced worker health and safety while allowing industry flexibility in demonstrating compliance with regulations.

Recommendation 1b. BOEM and BSEE should lead stakeholders in developing a clear SMS standard similar to API RP 75 or SEMS so that the industry has a document against which to judge SMS programs and their effectiveness. Furthermore, BOEM and BSEE should lead stakeholders in developing guidelines and recommended practices that could be used as guidance documents or adopted by reference.

BOEM and BSEE should encourage the wind industry to develop a clear SMS standard, as well as voluntary guidelines and consensus standards that supplement an enhanced SMS rule. It is important for BOEM and BSEE to engage in the standards development process and actively participate on committees that develop such standards to improve the agencies' understanding of the industry they regulate. Enlisting the help of industry stakeholders in crafting guidelines and recommended practices, similar to the American Wind Energy Association's (AWEA's)

Recommended Practices for Design, Deployment, and Operation of Offshore Wind Turbines in the United States released in 2012, can facilitate cooperation if BOEM chooses to utilize such documents as guidance or to adopt them by reference.

Finding 6. According to 30 CFR 585, and as explained to the committee by the sponsor, the scope of BOEM’s SMS covers all activities and all facilities described in and conducted under a lessee’s site assessment plan (SAP), construction and operations plan (COP), or general activities plan (GAP), regardless of jurisdictional boundaries.

According to the regulations in Subpart H of 30 CFR 585, all activities, both onshore and offshore, described in an approved COP, SAP, or GAP must be conducted “in accordance with” the organization’s fully functioning SMS. An organization’s entire safety approach for all phases of a project is included in the SMS’s scope.

Recommendation 2. BOEM’s enhanced SMS rule should be contained in a single document; should encompass all activities including construction, operation and maintenance, and a framework for decommissioning; and should promote a positive safety culture within an organization. The SMS rule should be supplemented by specific requirements sufficient to ensure consistent health and safety performance across the population of operators and contractors and to provide equal protection for employees at all locations, regardless of jurisdiction.

Although BOEM’s jurisdiction starts beyond state waters (on the OCS), an effective SMS should cover all activities and operations for all project phases and for all facilities, even if those activities occur outside of BOEM’s jurisdiction. A lessee’s policies and procedures documenting worker health and safety for offshore wind farms do not begin 3 nautical miles offshore, and neither should the lessee’s SMS. The SMS exists to define an organization’s health and safety policies and the responsibilities of key personnel, to identify hazards that can lead to incidents for all phases of a project, to determine the risk associated with each hazard, and to identify appropriate precautions to decrease the likelihood of incidents and mitigate any that occur. An SMS provides the foundation

for an effective safety culture, which is key to sustainable safety, and provides a mechanism for managers to verify that the implemented health and safety policies and procedures produce the intended results and to take corrective action, if necessary.

Finding 7. Well-defined federal occupational health and safety regulations (a national regulatory framework) for offshore wind farms on the OCS would also provide a resource for OSHA and the state programs as they develop regulations for U.S. waters within 3 nautical miles and on the Great Lakes.

Finding 8. Many OSHA standards for either general industry (29 CFR 1910) or the construction industry (29 CFR 1926) can be applied to potential hazards in the offshore wind industry. Likewise, USCG regulations in the (forthcoming) revised Subchapter N (33 CFR 140–147) could be applied to these hazards.

Although many OSHA and USCG regulations are prescriptive, they offer guidance and preventive strategies for ensuring safe work practices and could help BOEM develop a supportive structure for offshore safety that provides additional details governing the control of specific hazards. Examples of such guidance include control of hazardous energy sources (i.e., lockout and tagout) and arc flash and procedures for working safely in confined spaces. OSHA regulations that pertain to onshore wind turbine worker safety could be appropriate for wind turbines on the OCS when the hazards are similar. However, some regulations, such as those for diving, are out of date and in the committee's opinion require revision. The committee notes that OSHA has neither vessels nor resources for enforcing worker safety requirements for wind farms within state waters, on the Great Lakes, or on the OCS. BOEM could adapt OSHA regulations into its regulatory framework, although this would require BOEM inspectors to be trained in enforcing those requirements.

Recommendation 3. Together with stakeholders, BOEM and BSEE should assess in detail the adequacy of current U.S. (e.g., OSHA and USCG) and foreign (e.g., UK Health and Safety Executive) regulations and marine construction guidelines in addressing the hazards for offshore wind farm worker health and safety on the OCS.

Chapter 4 sets forth applicable regulations and recognized best practices in health and safety in the United States and internationally. BOEM and BSEE should use this information to assess in detail the regulations and guidelines that apply to offshore wind farms and determine their efficacy. On the basis of this inventory and the common recognized hazards on wind farms regardless of their location, the committee recommends that BOEM and BSEE work closely with other regulatory agencies and consult with industry groups to develop consistent regulatory practices independent of the location of the wind farms. The regulatory practices would be contained in a single document (see Recommendation 2) and provide a resource for agencies developing similar regulations in other jurisdictions.

Finding 9. A central element of designing for safety is a focus on HFE. Because prescriptive requirements do not always keep up to date with industry’s best practices and design principles, adhering to design standards that attend to HFE elements (one example is ASTM F1166-2007, *Standard Practice for Human Engineering Design for Marine Systems, Equipment, and Facilities*)¹ could address this problem.

HFE improves the interface between workers and the systems and equipment they operate and maintain by incorporating elements of management participation, workplace design, environmental control, and job aids into the design and operation of a safe and efficient work site. The prevention through design (PtD) initiative is based on the premise of “designing out” hazards and risks. Wind farms are less likely to experience a large, catastrophic event, such as the *Deepwater Horizon* explosion. Because wind turbines are unmanned and are spread over a large area, a limited number of workers are exposed to hazards at one time, in contrast to an oil and gas platform. Emphasizing the reduction of personal events through the introduction of HFE elements early in the design process could greatly improve worker health and safety in the operation of offshore wind farms.

¹ The American Society for Testing and Materials, now known as ASTM International, develops and delivers international voluntary consensus standards.

Recommendation 4. BOEM and BSEE should require the inclusion of HFE and PtD elements in any updated SMS requirement for off-shore wind farms.

Design is critical in ensuring worker health and safety. Addressing hazards and risks early in the design process is recognized as a key strategy for reducing or eliminating workplace injuries and fatalities, especially personal safety events. The HFE discipline and the PtD initiative provide opportunities for identifying and eliminating hazards during the design phase. In the opinion of the committee, they are vital elements for any SMS.

Finding 10. A memorandum of agreement (MOA) exists between BOEM (originally the Bureau of Ocean Energy Management, Regulation, and Enforcement) and USCG, and a memorandum of understanding (MOU) exists between USCG and OSHA. However, the memoranda are unclear as to which health and safety regulations will be enforced (and by whom) and do not adequately cover worker health and safety on OCS wind farms.

The MOA between BOEM and USCG sets a framework for communication and cooperation throughout the OREI process by avoiding overlapping and duplicative regulations with regard to vessels servicing OREIs, but it does not adequately cover worker health and safety. The MOU between USCG and OSHA does not discuss the likely introduction of OREIs in state waters. Industry has indicated a desire for consistent enforcement of standards. Although consistent regulatory practices are important, so too is a set of MOUs clarifying which agency will cover what and where industry will turn for answers to procedural questions. During a recent meeting, representatives of all three agencies (DOI, OSHA, and USCG) determined that agreements would need to be updated to reflect the likelihood of shared responsibility for investigations. Ideally, a tri-lateral agreement for perceived violations would encourage collaboration across regulators and geographical jurisdictions.

Recommendation 5. BOEM should examine its MOA with USCG, and USCG should review its MOU with OSHA in light of the certain development of OCS renewable energy projects. The updates of

both memoranda should set forth clearly defined health and safety roles for each agency and indicate which standards will apply for all phases regardless of jurisdictional boundary. A tripartite MOU could provide the most clarity.

Finding 11. Valid and reliable data are essential for monitoring safety performance and assessing organizational goals and policies and are generated as part of an organization's internal audit. Organizations can use key performance indicators (KPIs) to extract lessons that can be used to improve worker safety through better design, operational procedures, and organizational policies.

Leading indicators, such as hazards identified and addressed, are proactive measures that can suggest the possibility of an incident or the presence (or lack) of a safety culture. Lagging indicators, such as injuries per time period, are reactive measures after an event or accident and tend to gauge past trends or performance. Developing metrics and collecting data are important tools for management in reporting outcomes, setting strategy, supporting decision making, and implementing corrective actions with regard to safety performance. As noted at industry conferences, however, companies may be cautious about releasing health and safety data because of concerns with regard to potential litigation or greater regulatory scrutiny, even though maintaining and sharing data on KPIs in sufficient detail are important goals for the wind energy industry. Standards for reporting indicators therefore need to be developed; furthermore, standards for keeping records of this information and appropriate collection and publication of the indicators are priorities.

The International Marine Contractors Association (IMCA) collects, analyzes, and shares data on industry incidents from work in offshore construction. The reports developed by IMCA contain descriptions of incidents, near misses, and potential hazards and give the apparent cause (or causes) of the incident and any actions taken to prevent a recurrence.

IMCA surveys its members annually for additional safety information. KPIs used in the survey are developed by the association. The safety performance statistics produced by IMCA allow member organizations to identify trends within the industry and to measure their performance

against industry averages, thus allowing organizations to improve safety performance and reduce injury rates.

Recommendation 6a. The committee supports AWEA’s attempt to benchmark industry safety data through an anonymous survey and to share the results of the survey with its members. To track success or problems in managing health and safety on OCS wind farms, **BOEM should enlist the help of industry and industry stakeholders in researching and developing standards for KPIs and in collecting, storing, and publishing this information.**

BOEM should look to IMCA’s model of data collection and distribution as it works with wind industry stakeholders to develop KPIs.

Recommendation 6b. **BOEM should require organizations operating on the OCS to submit all internal audit plans, including relevant KPIs to be collected, electronically.**

BOEM should use this information, along with information from BOEM inspection reports and operator self-inspection plans and reports, to conduct selective audits. The results of such audits should be used to encourage organizations to improve their safety performance. BOEM should strongly encourage industry to incorporate any lessons learned into designs for worker safety.

Finding 12. **BOEM’s inspection process for wind turbines is not well developed, nor is an audit process part of the regulations.**

As discussed in Chapter 5, the lessee must allow BOEM to conduct scheduled and unscheduled inspections of a lessee’s facilities and vessels and must demonstrate compliance with its own SMS. Although BOEM has published a *Process Guide* to clarify the offshore renewable energy process and produced a list of potential incidents of noncompliance for renewable energy, BOEM’s inspection process is not fully developed and will need clarification. In addition, auditing is identified as an important element in SMS standards, but neither internal audits nor audits conducted by BOEM are required in the current regulations. BOEM has indicated that the SEMS inspection and auditing processes under development for the oil and gas industry will provide guidance to the offshore

wind industry for future inspection policy and for any new audit process but that these plans are still in their early stages.

Recommendation 7. As it updates the inspection process and develops complete audit procedures, BOEM should examine the holistic approach recommended in the recent SEMS report as a model for offshore wind energy.

BOEM should evaluate the effectiveness of a lessee's SMS program on the basis of principles outlined in the SEMS report (TRB 2012), which recommends a combination of approaches for an effective SMS, including government compliance inspections and operator and government audits. The committee supports this report's recommended approach in principle and agrees that while "ensuring compliance with specific regulations" has its place, an SMS inspection "should not be focused solely on what is not in compliance" but should also "attempt to obtain a holistic view of the facility's safety culture" (TRB 2012, 95). The report goes on to say that inspections "should look beyond the written regulations to identify operators in marginal compliance," despite the difficulty of assessing the adequacy of an SMS, and should "make overall observations, which, in turn, could help focus" an audit (TRB 2012, 96).

The SEMS report also outlines an extensive audit program that includes features such as operator ownership and quality assurance of audits. The committee agrees with the SEMS report that an operator should be involved in an internal audit. An audit is more effective when it is performed by independent teams of the operator that are not associated with the activities being reviewed; such an arrangement "reinforces ownership" of the process and of the organization's "safety culture" (TRB 2012, 92). Likewise, BOEM should use internal audit plans (see Recommendation 6b) in combination with reports from BOEM inspectors and the lessee's self-inspection plans and reports to direct its audits. BOEM's audits are critical for verifying that the operator's SMS audits are being conducted properly and that the lessee's managers are reviewing SMS audit reports and taking any necessary corrective action.

Although the frequency and scope of inspections and audits would need to be adjusted to address the risks associated with offshore wind

farms, many components of the approach recommended in the SEMS report would be appropriate for overseeing the offshore wind industry.

Finding 13. Neither BOEM nor BSEE has established training programs for offshore wind inspectors.

To carry out its mandate to conduct health and safety inspections of wind farms, BOEM will require well-trained personnel who understand the hazards and risks of the industry they regulate. Proper training of government regulatory personnel will be necessary as new health and safety regulations are instituted and inspection and audit processes are better defined. Any training program will require scalability as the offshore wind industry grows, but the scope of the potential program remains unclear.

Finding 14. Guidelines for health and safety training lack consistency between manufacturers and operators within the wind industry. Technicians often face redundant safety training and courses to receive certification to work on turbines from different manufacturers.

Although many companies in the wind industry have comprehensive training programs, the programs often lack consistent guidelines for minimum training requirements and recognition of competency. The committee endorses efforts by AWEA, RenewableUK, and the Global Wind Organisation to standardize common elements used by the wind industry for basic safety training courses and believes that such efforts are helpful in reducing this redundancy.

REFERENCE

Abbreviation

TRB Transportation Research Board

TRB. 2012. *Special Report 309: Evaluating the Effectiveness of Offshore Safety and Environmental Management Systems*. Transportation Research Board of the National Academies, Washington, D.C. <http://www.trb.org/Publications/Blurbs/167249.aspx>.

Study Committee

Biographical Information

Vice Admiral James C. Card, *Chair*, is a consultant to the maritime community. He has 42 years of maritime safety, security, and environmental protection experience in the U.S. Coast Guard (USCG) and the American Bureau of Shipping (ABS) and is a member of the Transportation Research Board's (TRB's) Marine Board. He chaired a National Research Council (NRC) planning committee on offshore wind energy projects. He was the USCG Vice Commandant from July 24, 1998, until his retirement on July 1, 2000. He served as Commander, Coast Guard Pacific Area, Eleventh Coast Guard District, U.S. Maritime Defense Zone Pacific, and as Regional Emergency Transportation Coordinator from 1997 to 1998. He was Assistant Commandant for Marine Safety and Environmental Protection at Coast Guard Headquarters, Washington, D.C., from 1994 to 1997 and was Commander of the Eighth Coast Guard District in New Orleans, Louisiana, from 1992 to 1994. As Pacific Area Commander, he directed Coast Guard operations from the West Coast to the Far East and from the North Pole to the Antarctic in support of the strategic goals of safety, protection of natural resources, mobility, maritime security, and national defense. Adm. Card has served as Chief of Staff, Thirteenth Coast Guard District, in Seattle, Washington; Chief of Operations for the Eleventh Coast Guard District in Long Beach, California; and Commanding Officer of Marine Safety Office, Group Los Angeles–Long Beach, California. He was also Commanding Officer of Marine Safety Office St. Louis, Missouri, and has had tours at Coast Guard Headquarters as Chief, Merchant Vessel Inspection and Documentation Division, and Chief, Ship Design Branch, in the Marine Technical and Hazardous Materials Division. He is a 1964 graduate of the U.S. Coast Guard Academy and has earned two master's degrees, one

in naval architecture and one in mechanical engineering, from the Massachusetts Institute of Technology. He is also a graduate of the Industrial College of the Armed Forces.

Thomas J. Lentz is a lead health scientist and research occupational hygienist and Chief of the Document Development Branch with the National Institute for Occupational Safety and Health (NIOSH), Centers for Disease Control and Prevention. He conducts research to evaluate occupational and environmental hazards. His projects and interests include investigation of small business industries and their hazards, assessment of safety hazards in construction trades, and evaluation of toxicology and epidemiology data on chemical and physical agents to determine health risks and appropriate prevention strategies. Dr. Lentz is particularly interested in studying how design, planning, and control engineering can be used in addressing safety and health challenges in the work environment. Major duties include developing informational materials and guidance for other agencies, industry, labor groups, and the public. He formerly served as Policy Response Coordinator for the institute. Dr. Lentz earned a BA in biology–philosophy from Wittenberg University (1989), an MPH in environmental health sciences–health policy from Yale University (1991), and a PhD in environmental health and industrial hygiene from the University of Cincinnati (1997).

Gerald E. Miller, with G. E. Miller and Associates, is the author of the original American Society for Testing and Materials F1166 *Standard Practice for Human Engineering Design for Marine Systems, Equipment, and Facilities*, which was published in 1988, and is the principal author of the 2007 revision. He has been employed for 50 years as a human factors engineer and has 32 years of experience in integrating human factors engineering into the design of ships and offshore oil and gas facilities. He is a member of TRB’s Marine Safety and Human Factors Committee. He has authored more than 70 papers, reports, and articles on the methods and value of integrating human factors engineering into the design of military and commercial ships and offshore structures. He has been a human factors and ergonomics (HFE) consultant to ABS since 1997 and was the technical author of its first ergonomics ship design guideline (*Guidance Notes on the Application of Ergonomics to Marine Systems*) in

1998. He was a subject matter expert consultant for the expanded and updated version of that document reissued in 2003. He also contributed to three ABS ergonomically based habitability design standards, released in 2003, covering crew spaces for all types of ships, passenger accommodations on cruise ships, and crew accommodations on offshore facilities. Mr. Miller was a consultant to ABS during the preparation of its ergonomics design guideline for the design of ship bridges, which was released in 2004, and served as the HFE specialist on an ABS project to clarify and quantify the existing HFE requirements contained in the ABS Steel Vessel Rules. Mr. Miller has written or contributed to five major publications that describe how to integrate HFE into the design of offshore rigs, platforms, and ships. Since 1990, he has served as an HFE consultant to more than a dozen offshore exploration and production companies, offshore drilling companies, and marine engineering and design companies in the Gulf of Mexico and internationally during the design of approximately 15 oil and gas rigs and platforms and offshore supply vessels. Mr. Miller served as an HFE consultant to the U.S. Coast Guard periodically from 1990 through 2001, including a 5-year stint as a visiting HFE instructor at its training center in Yorktown, Virginia. He has prepared more than a dozen PowerPoint-based HFE training packages and has personally provided HFE training to more than 3,500 maritime engineers, designers, computer-aided design operators, and inspectors in the United States and overseas. Mr. Miller holds a BS in civil engineering and an MA in clinical and experimental psychology and is a certified professional ergonomist.

Edmond J. Moran, Jr., is a member of senior management of Moran Towing Corporation and is a member of TRB's Marine Board. He is a graduate of Georgetown University and has served in the United States Navy. Mr. Moran has worked in the maritime industry for more than 40 years and has significant experience with maritime-oriented safety management systems. His background includes managing the safety of workers operating on offshore vessels and the safe and reliable delivery of personnel and equipment to and from offshore job sites, as well as the implications of vessel design and operation along with personal safety equipment. He is familiar with wind farm service vessels and has visited wind farm operators, developers, and service vessel operators in Europe and America to improve understanding of the industry.

Jakob Nielsen is Head of Environment, Health, and Safety (EHS) Offshore at Siemens Energy Transmission. Previously, he served as Head of EHS Offshore, New Markets, and Technology for Siemens Wind Power, where he led a global team whose focus was on EHS in the early stages of offshore projects. He identified and mitigated risk with regard to new markets and new offshore projects. In addition, Mr. Nielsen was the Head of EHS Offshore at Siemens Wind Power and was responsible for direct and functional management of EHS on all offshore wind projects worldwide. While he was the Global Health, Safety, and the Environment (HSE) Manager, he directed HSE work on a global level for all plants, production sites, and research and development test sites, including supplier control.

James W. Platner is Associate Director of the Center for Construction Research and Training, formerly known as the Center to Protect Workers' Rights, which is the research and training institute of the Building and Construction Trades Department, American Federation of Labor–Congress of Industrial Organizations. He has a BS in biophysics from Johns Hopkins University, an MS in radiation biology, and a PhD in toxicology from the University of Rochester School of Medicine. He is a Certified Industrial Hygienist and a Fellow of the American Industrial Hygiene Association. He is a member of the American National Standards Institute (ANSI) A10 American National Standards Committee on Safety in Construction and Demolition Operations and the ANSI Z10 American National Standards Committee on Occupational Health and Safety Management Systems. He is a coprincipal investigator of the NIOSH National Construction Research Center and is a member of the NIOSH Board of Scientific Counselors.

Jennifer L. Schneider is a Professor and Russell C. McCarthy Endowed Chair in the Civil Engineering Technology, Environmental Management, and Safety Department, College of Applied Science and Technology, at the Rochester Institute of Technology. She has been Director of EHS for ITT/Goulds Fluid Division; Regional Safety Supervisor, Mobil Chemical Corporation; and Engineer–Industrial Hygiene Specialist, IT Corporation/Eastman Kodak. She received a BA from Roberts Wesleyan College, an MS from the University of Rochester School of Medicine

and Dentistry, and an ScD from the University of Massachusetts College of Engineering. She is a Certified Industrial Hygienist—Comprehensive Practice (Diplomate). Her research interests include critical infrastructure: application of risk analysis and systems theory to determine community-level critical infrastructure, impacts on emergency management systems and target capabilities; exposure assessment: modeling of exposure scenarios (particularly hazardous material emergencies) and requisite response needs; and multidimensional sustainability: analysis of sector-based corporate sustainability-related activities and management systems.

Robert E. Sheppard is a Technical Manager with Energo Engineering, an engineering consulting firm specializing in advanced analysis, integrity management, and risk and reliability, in Houston, Texas. He has more than 20 years of experience in structural engineering with a focus on assessment and repair of offshore structures and structural integrity management. He has extensive experience in planning and implementing offshore inspection activities and in the design and installation of offshore repairs, including working with divers and installation contractors to facilitate their ability to perform work safely offshore both above and below water. Mr. Sheppard was the group leader for safety, operations, and decommissioning in the American Wind Energy Association's *Recommended Practices for Design, Deployment, and Operation of Offshore Wind Turbines in the United States*. He has led projects for the former Minerals Management Service to develop guidelines for the inspection of offshore wind turbine facilities, including the substructure, tower, nacelle, and blades. These projects blended the existing operating experience from offshore oil and gas facilities with the unique requirements of wind turbine facilities. He has also recently worked on a TRB study committee addressing the structural integrity of offshore wind turbines. Mr. Sheppard earned a BS in civil engineering from Rice University and an MS in structural engineering from the University of California, Berkeley. He is a registered civil engineer in California and Texas. He has published three papers related to offshore wind facilities.

Michael A. Silverstein is a Clinical Professor of Occupational and Environmental Medicine at the University of Washington School of Public

Health. He recently retired as Assistant Director for Industrial Safety and Health in the Washington State Department of Labor and Industries, where he was responsible for the state's occupational safety and health program for 10 years. Dr. Silverstein spent 2 years as Director of Policy for the Occupational Safety and Health Administration in Washington, D.C., and 15 years as Assistant Director for the Occupational Health and Safety Department of the United Automobile Workers Union in Detroit, Michigan. Before turning his attention full-time to the prevention of workplace injuries and illnesses, he practiced family medicine in Redwood City, California, and occupational medicine in Detroit. He has an AB from Harvard College, an MPH from the University of Michigan School of Public Health, and an MD from Stanford University School of Medicine. His research interests include occupational health policy, regulatory and legislative policy, ergonomics, safety and health programs and procedures, and workers compensation issues.

Brian Walencik is the Environmental Health and Safety Leader for Renewable Energy at GE Power and Water. He manages a program that develops competency in environmental health and safety for GE professionals and directs an initiative promoting mentoring opportunities between junior employees and senior environmental health and safety leaders. Mr. Walencik has more than 18 years of environmental health and safety experience with GE and has a BS in environmental law and economics from the State University of New York.

David H. Wegman is Professor Emeritus in the Department of Work Environment at the University of Massachusetts, Lowell, and Adjunct Professor at the Harvard School of Public Health and the University of Massachusetts Medical School. He was founding chair of the Department of Work Environment as well as Dean of the School of Health and Environment from 2003 to 2008. Previously he was a member of the faculty at the Harvard School of Public Health and was Division Chair of Occupational and Environmental Health at the University of California at Los Angeles School of Public Health after serving as Occupational Hygiene Physician for the Massachusetts Department of Labor and Industries. He received his BA from Swarthmore College and his MD and MSc from Harvard University. Dr. Wegman's epidemiologic

research includes study of acute and chronic occupational respiratory disease, occupational cancer risk, and occupational musculoskeletal disorders. He has special interest in the study of subjective outcomes as early indicators of health effects and in surveillance of occupational conditions and risks. He was named a National Associate of NRC in 2002 and a member of the NRC Board on Human Systems Integration in 2010. Dr. Wegman has served on or chaired a number of ad hoc committees of the National Academies. Most recently, he chaired the Committees on the Role of Human Factors in Home Health Care and on External Evaluation of the National Institute of Disability and Rehabilitation Research. Previously, he chaired the NRC–Institute of Medicine Committees on Review of NIOSH Research Programs, the Health and Safety Needs of Older Workers, and the Health and Safety Consequences of Child Labor. He serves on the NRC Committee on Mine Safety: Essential Components of Self-Escape. Dr. Wegman chaired the 1995–1996 Mine Safety and Health Administration Advisory Committee on the Elimination of Pneumoconiosis Among Coal Mine Workers and served on the Boards of Scientific Counselors for NIOSH and for the National Toxicology Program as well as on the Environmental Protection Agency’s Science Advisory Board. In 1998 he was awarded a Fulbright Senior Fellowship for the study of health and safety of older workers in Sweden, and in 2006 he was appointed chair of the International Evaluation Group assisting in an analysis of occupational health research in Sweden. He is coeditor of *Occupational and Environmental Health: Recognition and Prevention of Disease and Injury*, the sixth edition of which was published in 2010.